



Hitachi Zosen
INOVA

Hitachi Zosen Introduction

Hitachi Zosen Inova

Global leader in Energy from Waste

Hitachi Zosen Corporation (Hitz)

- | Founded in 1881, 9500 employees
- | Osaka, Japan based industrial and engineering company focused on the waste and environmental business sectors.
- | Revenue ~3.7 billion USD (3/16)



● Hitachi Zosen Locations

Hitachi Zosen Inova (HZI)

- | 100% wholly owned subsidiary of Hitachi Zosen
- | HZI is the global market leader in energy from waste solutions; over a \$1 BUSD in annual Order Intake
- | HZI is headquartered in Zurich, Switzerland with offices in Germany, Italy, Slovakia, Sweden, China, Australia, USA, Canada, etc...
- | HZI with proprietary products span incineration, anaerobic digestion, renewable natural gas processing, and moving quickly into methanation, hydrogen and CO2
- | Over 500 reference projects worldwide
- | Dedicated R&D continuously improving and expanding

Hitachi Zosen Inova

Global leader in Energy from Waste

HZI North America

- | USA office established in 1975 (former A&E Von Roll)
- | North American HQ is in Knoxville, TN
- | Approx. 50 employees ('20) w/ growth to ~100 2021('21)
- | Full Sales and Business Development Capabilities
- | Full Engineering, Procurement, and Construction Capabilities
- | Full Project Financing Capabilities
- | Diverse Approach - Design and Supply, Design and Build, and Build Own Operate Approach





Hitachi Zosen
INOVA

Kompogas® - Anaerobic Digestion Technology

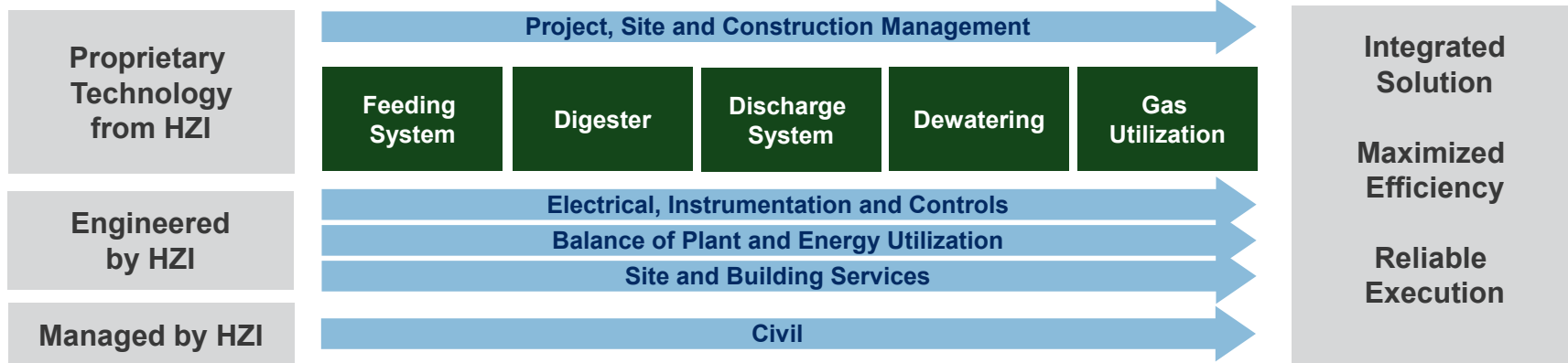
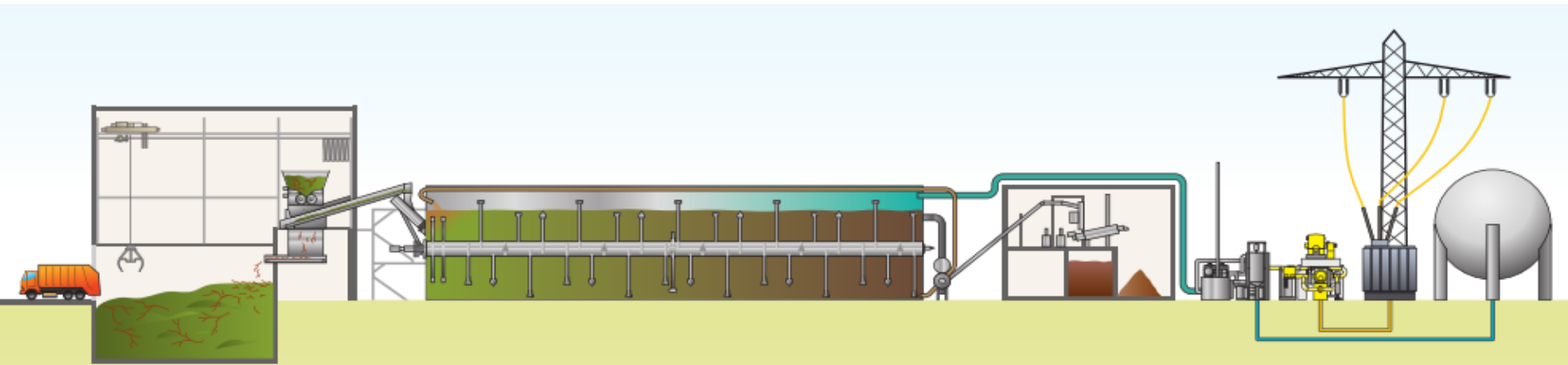

Hitachi Zosen Inova

Proven Industry Advantages

Robust, Reliable and Scalable



- | KOMPOGAS ensures very short construction times
- | Standardization of basic modules
- | KOMPOGAS reduces the investment costs
- | Easy integration of KOMPOGAS in existing plants
- | Easy extension of capacity utilizing the modular system
- | KOMPOGAS digester offers flexibility of accepting different waste streams over the course of the useful plant life
- | Robust design and construction minimizes OPEX and maintenance cost

Hitachi Zosen Inova

Global leader in Energy from Waste

HZI North America

| **San Luis Obispo AD Plant ('18) – San Luis Obispo, California**

- | Built, Own and Operate an Anaerobic Digestion Plant in San Luis Obispo, California in 2018
- | 20yr Waste Supply Agreement with WCI and 20 yr Power Purchase Agreement with PG&E
- | Received a Cal Recycle Grant (maximum award of \$3M USD)

| **Enbridge Biogas Upgrading Plant ('20) – London, Ontario Canada**

- | Designed, Supplied, and Constructed a biogas processing and compression plant
- | Met all Customer performance guarantees

| **Escondido AD Plant ('21) – Escondido, California**

- | Currently Constructing and Commissioning an Anaerobic Digestion and Biogas Upgrading for a Large Southern California Waste Hauler
- | Received a Cal Recycle Grant (maximum award of \$3M USD)

| **Lancaster AD Plant ('24) – Lancaster / Palmdale, California**

- | Currently Developing an HZI Owned and Operated Anaerobic Digestion and Biogas Upgrading Plant for the Largest Waste Hauler in the United States
- | Received a Cal Recycle Grant (maximum award of \$3M USD)

Intend to Place \$1 Billion of Renewable Gas Asset in the USA/Canada in the Next Decade

Hitachi Zosen Inova Reference Project –San Luis Obispo, CA

Client	Hitachi Zosen Inova
Location	San Luis Obispo, CA
Start-up	2018
Technology	
Plant type	High Solids AD & CHP
Technology	KOMPOGAS
Feedstock	Green Waste / Source Separated Organics
Technical Data	
Design Capacity	36,5000 tons/yr
Electricity Output	6,321,000 kWh/yr



- HZI owned & operated
- First in North America
- First unit certified on all US Codes and Standards
- Operating 24/7

London BMU - Ontario Canada



Client	Storm Fischer / Enbridge Gas
Location	London, ON
Start-up	2019
Technology	
Plant type	Gas Upgrading Plant
Technology	Membrane Technology
Feedstock for biogas	Green Waste / Source Separated Waste
Technical Data	
Feed gas capacity	1,200 Nm ³ /h
Product gas capacity	800 Nm ³ /h

- | SSO Facility
- | Extension of existing biogas plant generating electricity; now the biogas is also upgraded to produce renewable natural gas (biomethane).
- | HZI BioMethane's first turnkey gas upgrading project in Canada.
- | First gas upgrading by Enbridge Gas in Ontario.
- | First unit certified on all Canadian Codes and Standards.

Hitachi Zosen Inova Reference Project – In Commissioning – Escondido, CA



Concept Rendering



Client	SANCO Services / EDCO Disposal
Location	Escondido, CA
Start-up	2021
Technology	
Plant type	High Solids AD & Biogas Upgrading Plant
Technology	KOMPOGAS AD & Membrane Technology
Feedstock	Green Waste / Source Separated Organics
Technical Data	
Design Capacity	93,000 tons/yr (Phase I)
Design Gas Output	144,000 MMBtu/yr

Hitachi Zosen Inova

Lancaster – Concept 3D Model – Preliminary / Work in Progress

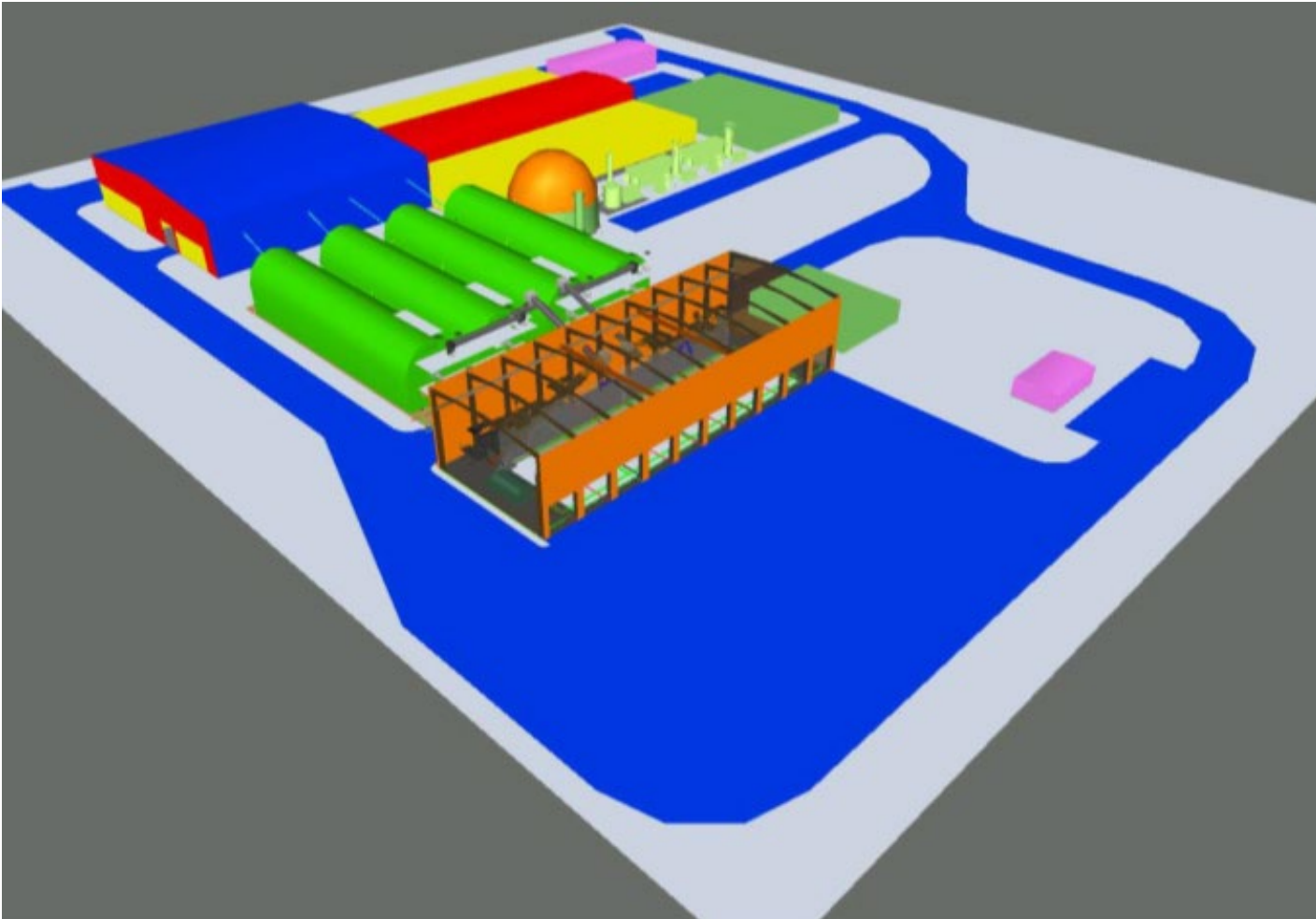



Hitachi Zosen
INOVA

HZI Designed, Operated & Owned Plant in Development
(EXAMPLE)

Lancaster - Antelope Valley, CA

PROJECT BACKGROUND - GENERAL

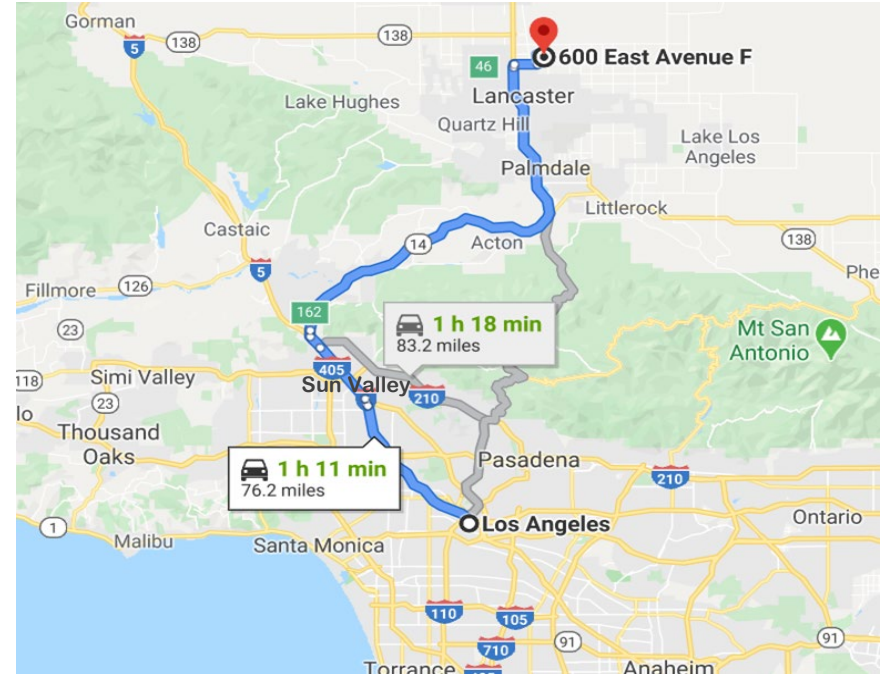

- Located 6 miles East of Lancaster / 13 miles North of Palmdale / 70 miles North of Los Angeles.
- Strategically location with large service territory of Northeast Los Angeles and Antelope Valley.

Item	Population
City of Lancaster	160,300
City of Palmdale	152,750
Los Angeles County	10,160,000
Los Angeles Metro Area	18,788,800

- Site is in second largest metropolitan region in the U.S. (pop. >18M).
- Strong and diverse regional economy provides ample feedstock supply.
- Demand for AD increasing ahead of 2022 organics landfill diversion compliance deadlines.

Item	Contents
SPV	HZIU BioEnergy Lancaster LLC
Plant	HZI Kompogas AD with Biogas Upgrading
Site	600 East Avenue F, Lancaster, California, 93535 (Los Angeles County)
Capacity / Digester	182,500 tpa (500 tpd) organic waste, PF2100 x 4
Waste Composition	Green waste (90%), food waste (10%)
Biogas Production	866 SCFM
Biomethane (RNG)	193,134 MMbtu/a
Compost	Local agriculture and offered to community
Liquid fertilizer	Processed liquid digestate for dust control at LF site and agricultural use

PROJECT BACKGROUND – PROCESS FLOW

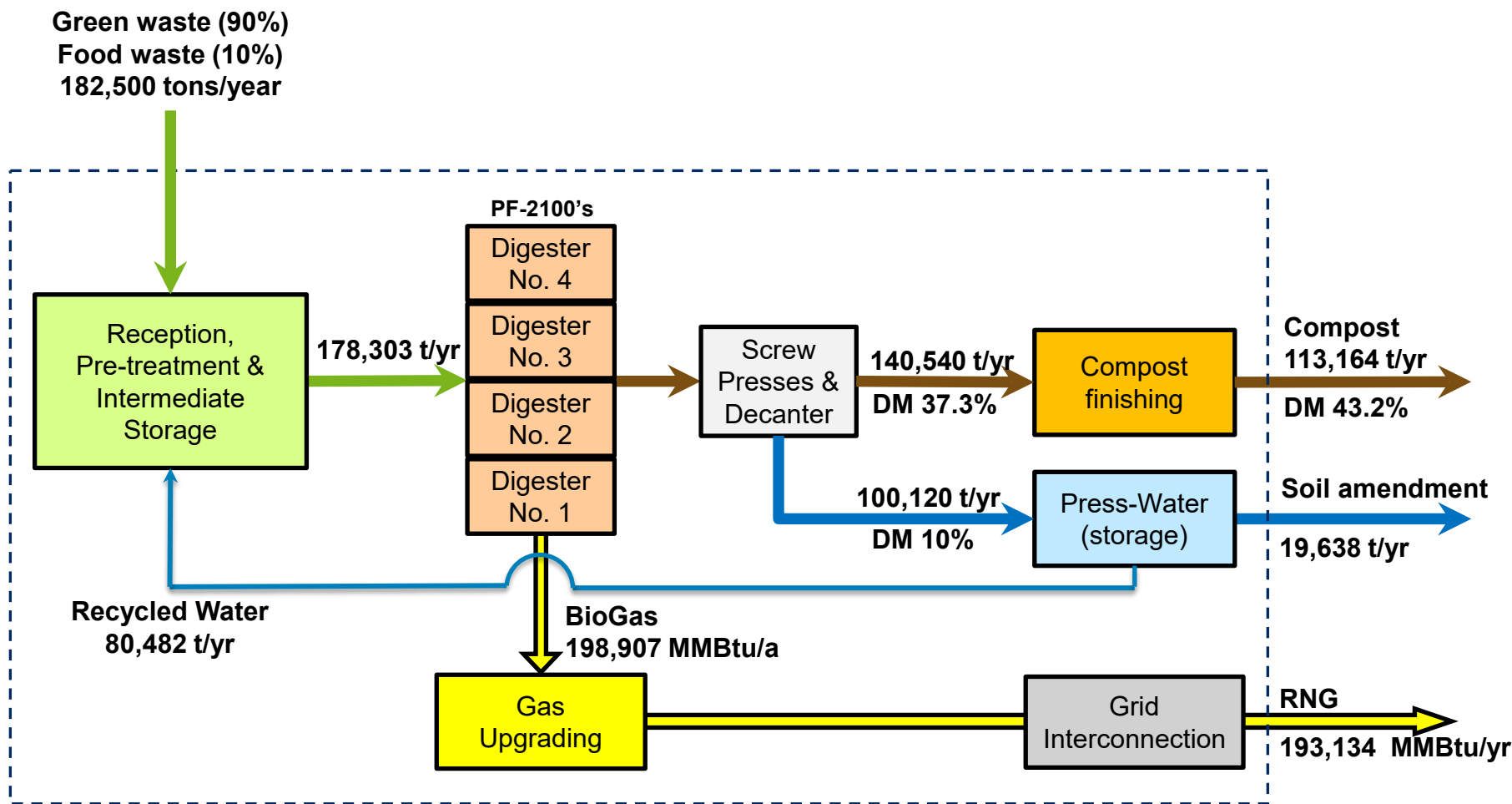

Waste is our Energy.
Engineering is our Business.
Sustainable Solutions are our Mission.

Thomas F Gratz
E-mail: Thomas.gratz@hz-inova.com