

Our Company

Orion Solar Racking specializes in Engineering, designing, development and manufacturing of photo-voltaic Mounting solutions. Since its foundation Orion has released a wide range of quality and innovative mounting systems. We provide roof-mount, ground mount, carports for commercial, agriculture, industrial, government & educational as well as utility grade projects.

Each and every day we endeavor to make simple yet innovative solar racking solution, Orion provides LIVE technical support for all of distributors, dealers and contractors.

Here at OSR, you can trust our knowledge of installation, code compliance and necessary technical documentation to always be above the rest.

Online tools like our Web-estimator Video installation videos and our IN-House Research & design teams that are eager to help you solve your toughest construction challenges. We now play a leading role in the solar industry and have a rapidly gained recognition amongst system integrators, installers and distributors across the world.

Mission Statement

Our mission has always been to provide quality products and promote green renewable energy Solutions, that reduce our dependency on earth depleting methods that may contaminate our environment.

Handling & Installing Orion Solar Racking

It is critically important to observe standard safety practices when installing Orion Solar Racking:

- Stop work during stormy weather. Solar modules can be caught in the wind.
- Never step or sit on the glass surface of a solar module. The glass may break, resulting in shock or bodily injury.
- Do not throw or roughly handle any Orion Solar Racking components.
- Do not bring the Orion Solar Racking into contact with sharp or heavy objects.
- Do not modify Orion Solar Racking components in any way. The exchange of bolts, drilling of holes, bending and any other physical changes not intended in standard installation procedure will void the warranty.
- Product should be installed and maintained by qualified personnel. Keep unauthorized personnel away from solar modules.
- It is the installer's responsibility to verify the integrity of the structure to which Orion Solar Racking is fixed.
- Roofs or structures with rotten/ rusted bearers, undersized bearers, excessively spaced bearers or any other unsuitable substructure cannot be used with Orion Solar Racking, and installation on such structures could result in death or serious injury and will void the warranty.

Material Contact Warning!!

Grounding lugs, ground wire, and other material should be installed such that copper does not come into contact with aluminum or galvanized steel.



Photovoltaic Mounting System
E469627



Caulking Gun w/ approved sealant



Chalk Line Reel



6mm & 8mm Metric Allen Key/
6mm & 8mm Hexagonal Drive Bit



Construction Hart Hat



Construction Gloves



Adjustable Wrench



Drill with 7/32 Bit



Measuring Tape



7/16" & 1/2" Socket Head



Safety Harness



Roofing Bar



Torque Wrench

Before Installing

Caution: Refer to the section "Planning a Layout" before attempting installation. Failure to correctly establish the requirements of the proposed installation site is dangerous and will void the framing warranty.



Ballast Pan



Solar Belt



High Bracket



Low Bracket



Connect Belt



End Plate



Mid Clamp



SGB-5 Grounding Lug



Seismic Attachment Plate
(for ballast system)



Torch Down U-Anchor Product
(for Solar Belt, non ballast system)

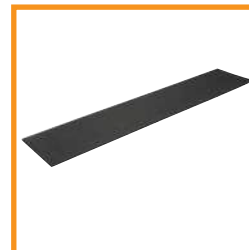

Rubber Pad*



Accessory Mounting Plate*



Side Ballast Tray*

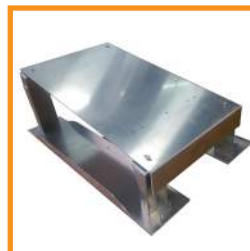

Inverter Mounting Plate*



Wire Management*



Ballast Blocks**

Note:

An Orion Racking Venus System can be identified by the Orion logo located on the Grounding Mid Clamp Cap as shown above.

*Optional Equipment

**Blocks can be purchased from any local hardware store or masonry distributor.

Vertical Chalk Lines

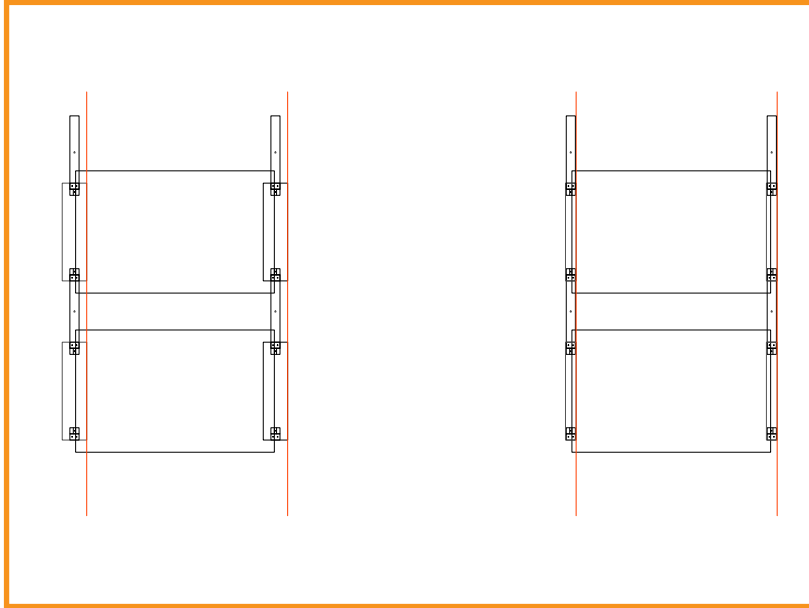

Vertical chalk lines will mark placement of the long edge of the ballast pan (or Solar Belt). When planning a layout, leave correct spacing from the edge of the panel to the edge of the ballast pan (or Solar Belt) to avoid encroaching into the fire walkways.

The first chalk line can run along the fire walkway border. Each subsequent vertical chalk line will be placed at a distance of:
 Panel Length + 0.75"

Horizontal Chalk Lines

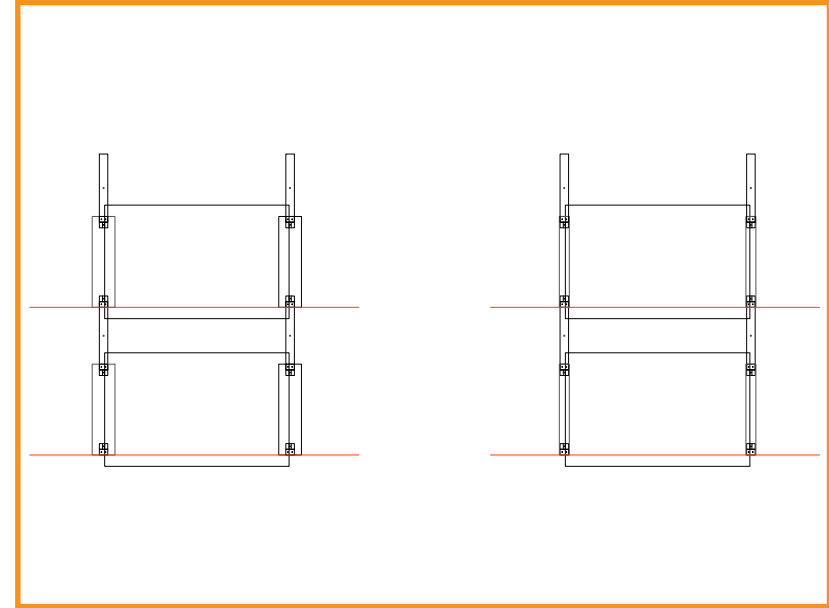

Horizontal chalk lines will mark placement of the short edge of the ballast pan (or Solar Belt). When planning a layout, leave correct spacing from the edge of the ballast pan (or Solar Belt) to the edge of the panel to avoid encroaching into the fire walkways (about 4" for typical 60 or 72 cell panel).

The first chalk line can run along the fire walkway border. Each subsequent vertical chalk line will be placed at a distance of:
 Panel Width + Pre-determined Row Spacing*

* Row spacing depends on system tilt, array azimuth, and project site location. Contact Orion Solar Racking for assistance in determining proper row spacing.

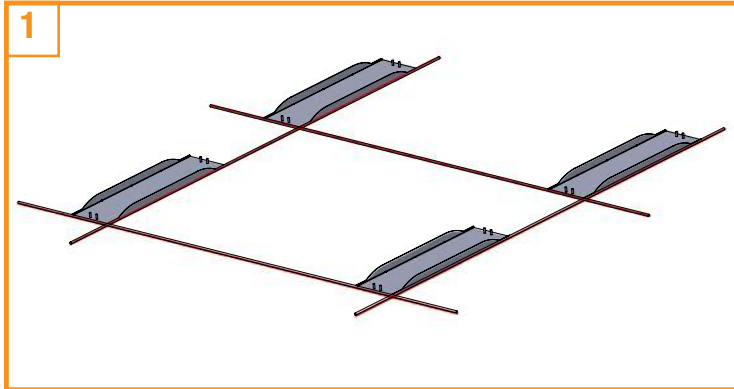

1 Align Ballast Pans (or Solar Belts) with pre-drawn chalk lines.

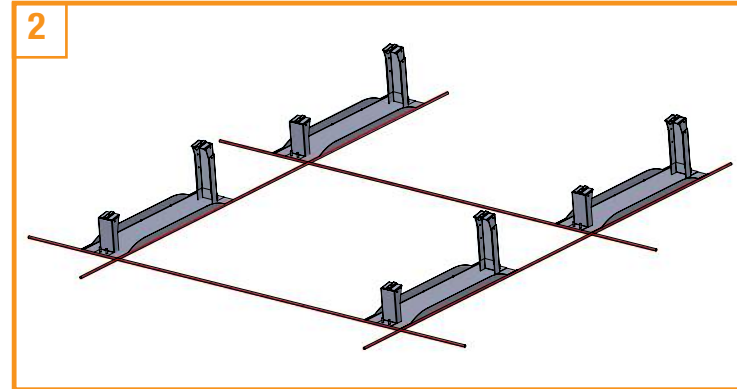

2 Place Brackets over integrated PEM Studs twicking out of each Ballast Pan (or Solar Belt). Do NOT secure hex flange nuts to PEM Studs at this time.

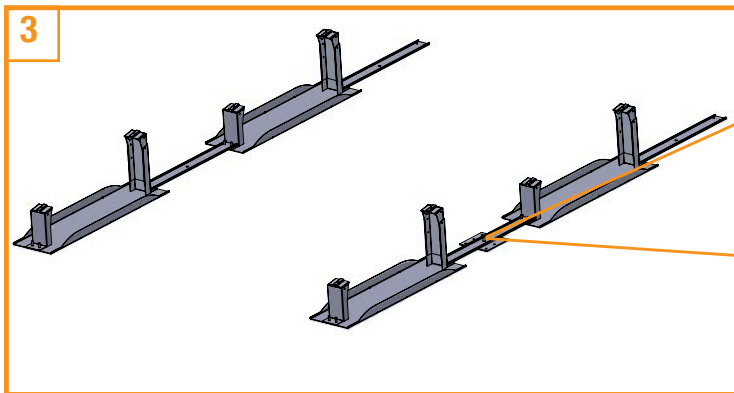

3 Add Connect Belts between each row over the top of the brackets on the PEM Studs. Add a 1/4-20 Stainless Steel Serrated Hex Flange Nut to each PEM Stud and tighten to **75 in-lb**.



Seismic Attachment Plate



U-Anchor

Note: If seismic attachment plates or U-Anchors have been predetermined, attach to connect belts before installing between rows. See Page 9 "Securing System" of this manual.

Installers should conduct periodic re-inspection of fasteners and any corrosion such that if found, the affected components are to be immediately replace

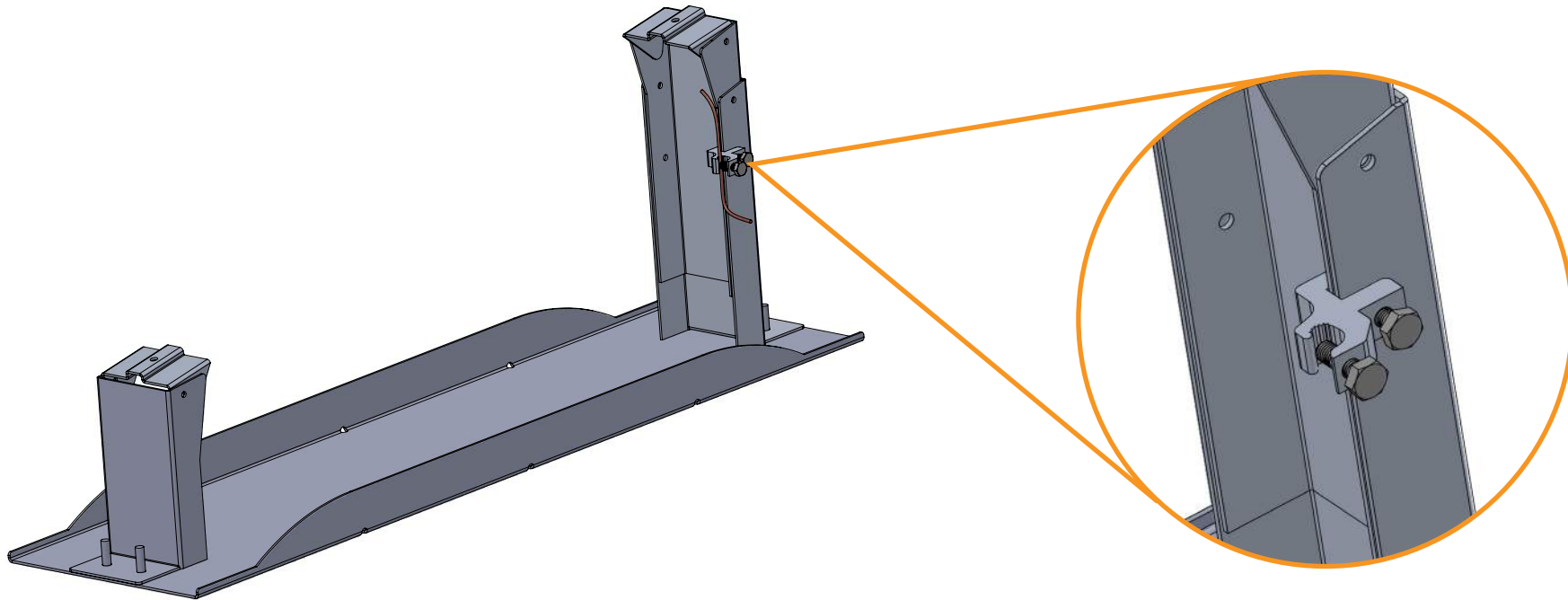

Ground lugs should be placed before PV Modules are installed. As a general rule, one SGB-5 Lug is required for every 56 modules in array. Apply lug to the edge of a high or low bracket as shown above. Bolt should be torqued to 20 in-lb.

The rest of the system will be bonded through integrated grounding methods:

- Grounding Mid Clamps
- Grounding End Plates
- Serrated Hex Flange Nuts

Grounding method used in accordance with the National Electrical Code, ANSI/NFPA 70. Orion's Belt System is evaluated for module-to-system bonding, only, to UL 2703.

Note:

Grounding Lugs are Single Use Only at a specific point on the Rail. If re-installation is necessary, the Grounding Lug must be shifted such that the Grounding Lug touches a new area of the Rail.

Material Contact Warning!!

Grounding lugs, ground wire, and other material should be installed such that copper does not come into contact with aluminum or galvanized steel.

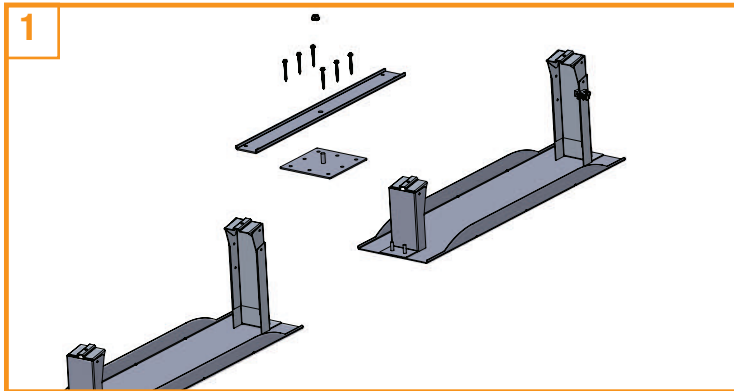

The Seismic Attachment Plate (SAP) is connected to the system through the center hole of the Connect Belt. Not every Connect Belt will need an SAP. Consult a qualified structural engineer to determine quantity and placement of SAPs.

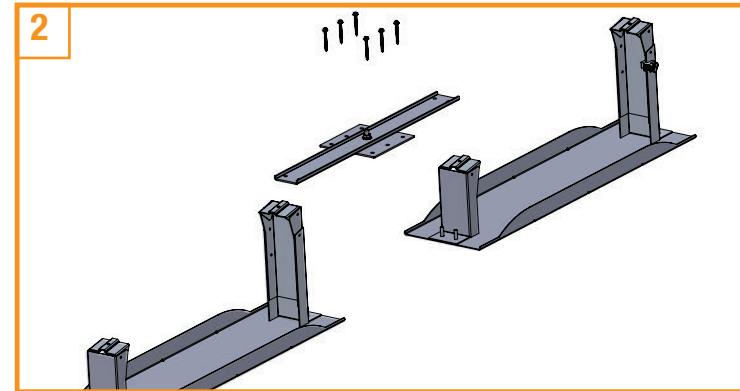

Tighten 3/8 Serrated Hex Flange Nut to **200 in-lb.**

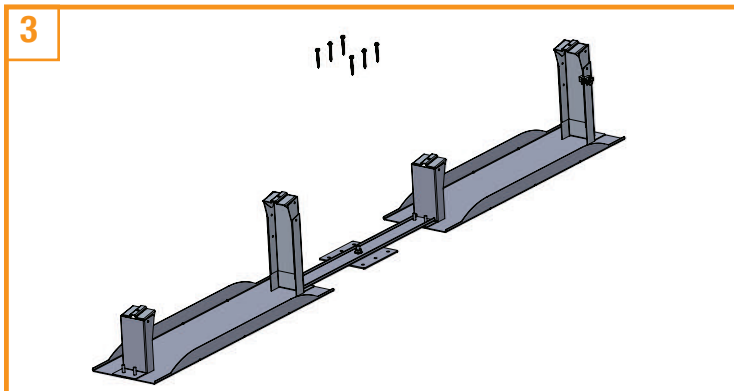

Replace the connect belt on the system and secure the 1/4-20 Serrated Hex Flange Nuts to **75 in-lb.**

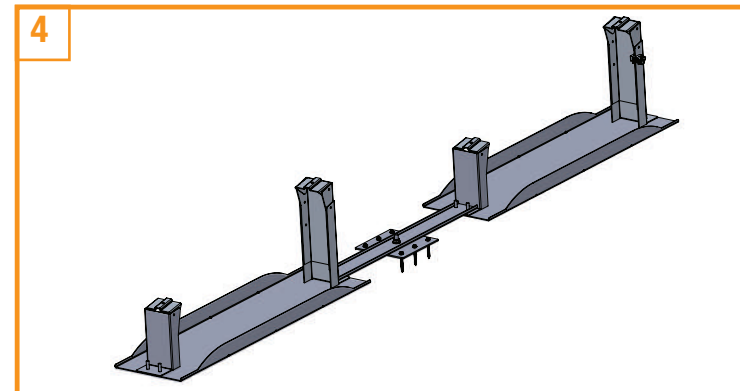

Insert 6 x roof appropriate fasteners through the holes in the SAP.

Consult a qualified roofer and/or structural engineer to determine roof appropriate fasteners. Seismic Attachment fasteners are not supplied by Orion Solar Racking.



1 Place PV Module on brackets and line Grounding End Plate up to span both brackets.

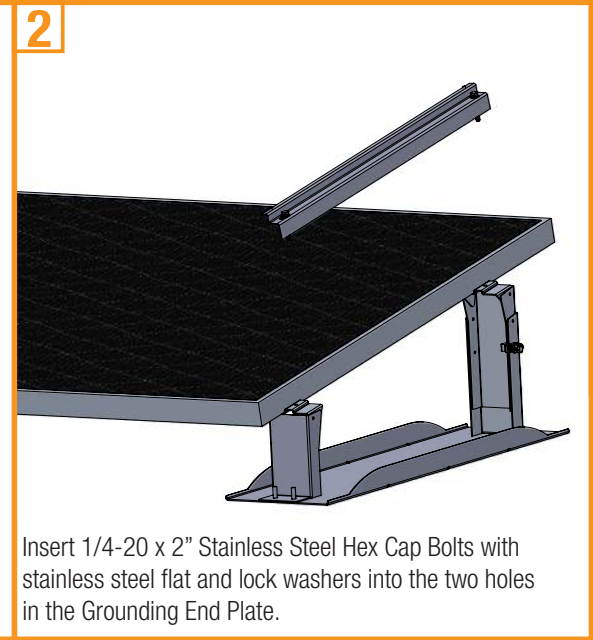

2 Insert 1/4-20 x 2" Stainless Steel Hex Cap Bolts with stainless steel flat and lock washers into the two holes in the Grounding End Plate.

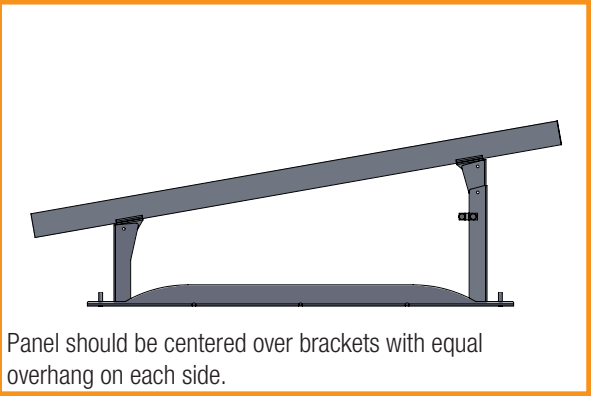

Panel should be centered over brackets with equal overhang on each side.

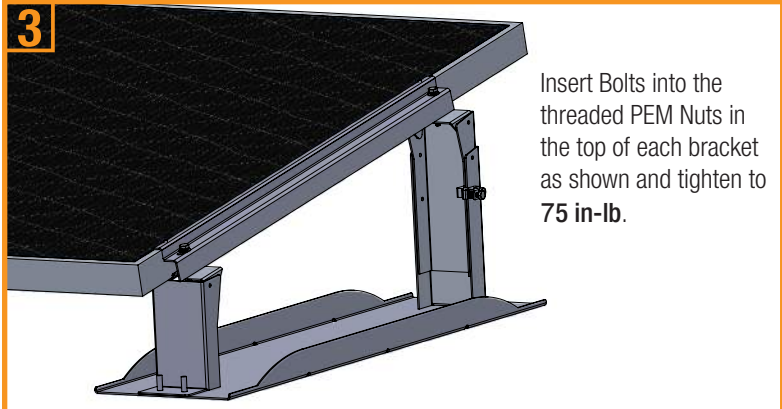

3 Insert Bolts into the threaded PEM Nuts in the top of each bracket as shown and tighten to **75 in-lb.**

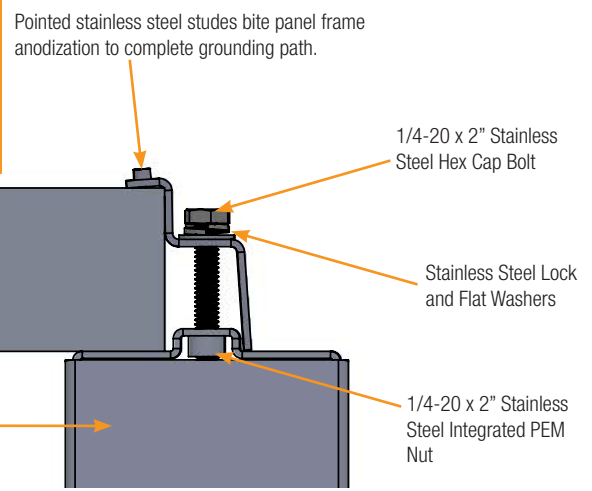

Pointed stainless steel studs bite panel frame anodization to complete grounding path.

Detail View of Grounding End Plate

Note:

Grounding End Plates are Single Use Only at a specific point on the PV Module. If re-installation is necessary, the PV Module must be shifted such that the Studs in the Grounding End Plate touch a new area of the frame.

Technical Specifications:		
Hardware:	Dimensions:	Material:
Hex Cap Bolt	1/4-20x2"	18-8 Stainless Steel
Lock Washer	ID: 0.260" OD: 0.487"	18-8 Stainless Steel
Flat Washer	ID: 0.281" OD: 0.625"	18-8 Stainless Steel
Grounding End Plate	L: 28.5" H: PV Module Dependent	Aluminum 5052-H32
Pointed Grounding Stud	OD: 0.24" H: 0.23"	304 Stainless Steel

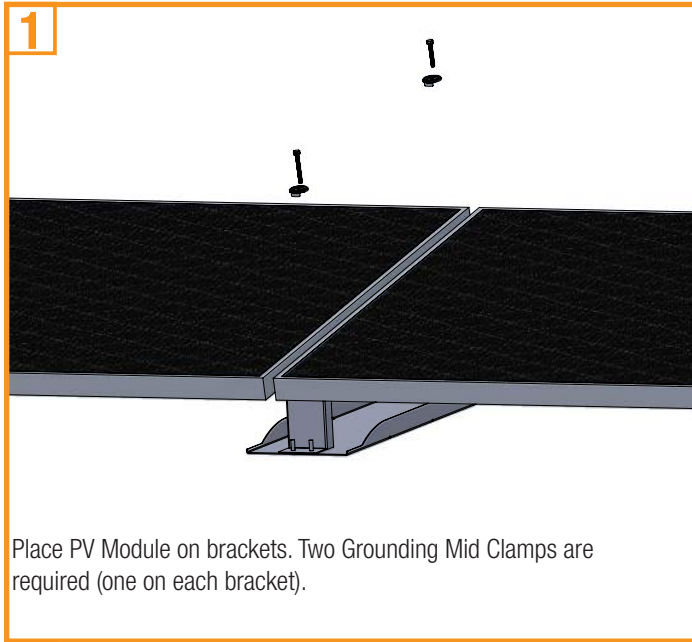

Place PV Module on brackets. Two Grounding Mid Clamps are required (one on each bracket).

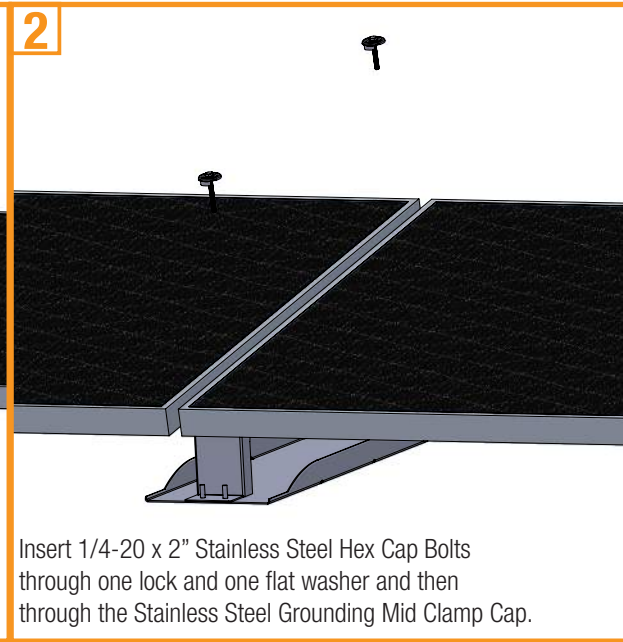

Insert 1/4-20 x 2" Stainless Steel Hex Cap Bolts through one lock and one flat washer and then through the Stainless Steel Grounding Mid Clamp Cap.

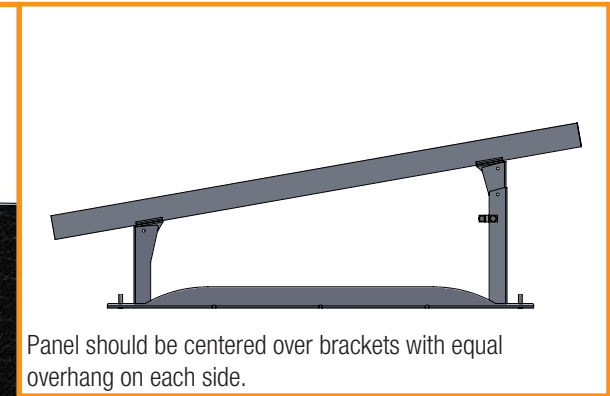

Panel should be centered over brackets with equal overhang on each side.

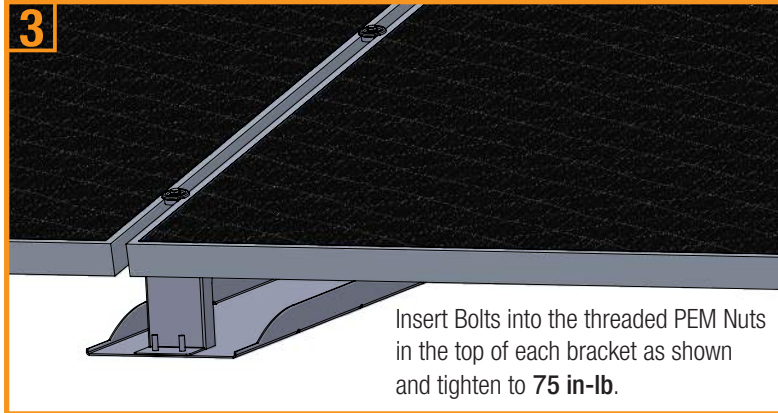

Insert Bolts into the threaded PEM Nuts in the top of each bracket as shown and tighten to **75 in-lb.**

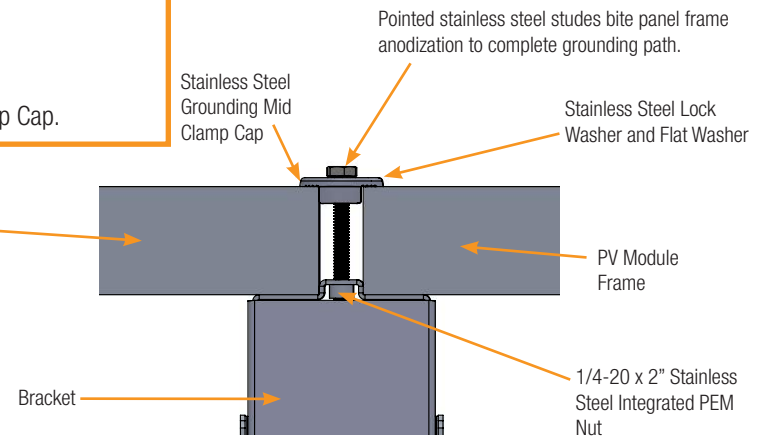

Detail View of Grounding End Plate

Note:

Grounding Mid Clamps are Single Use Only at a specific point on the PV Module. If re-installation is necessary, the PV Module must be shifted such that the Grounding Mid Clamp touches a new area of the frame.

Technical Specifications:		
Hardware:	Dimensions:	Material:
Hex Cap Bolt	1/4-20x2"	18-8 Stainless Steel
Lock Washer	ID: 0.260" OD: 0.487"	18-8 Stainless Steel
Flat Washer	ID: 0.281" OD: 0.625"	18-8 Stainless Steel
Grounding Mid Clamp Cap	OD: 1.36" H: 0.278"	301 Stainless Steel

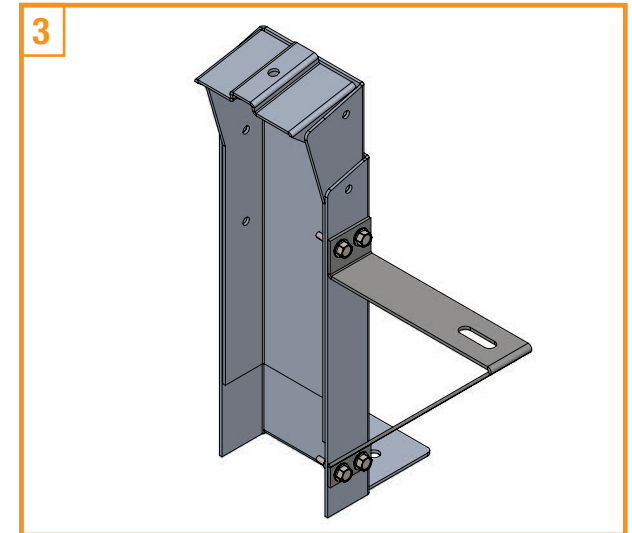
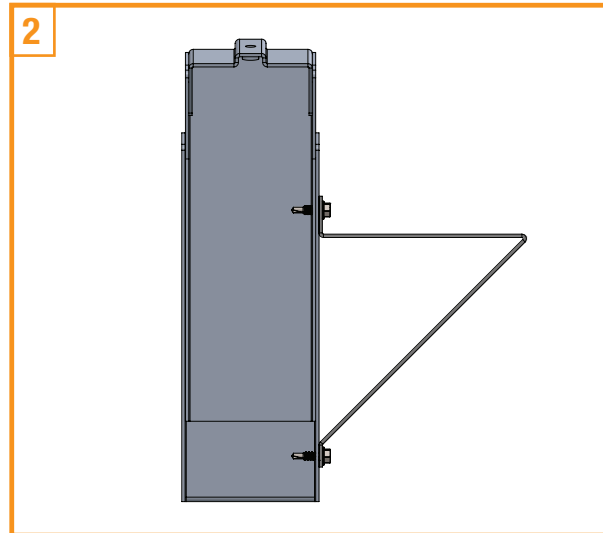
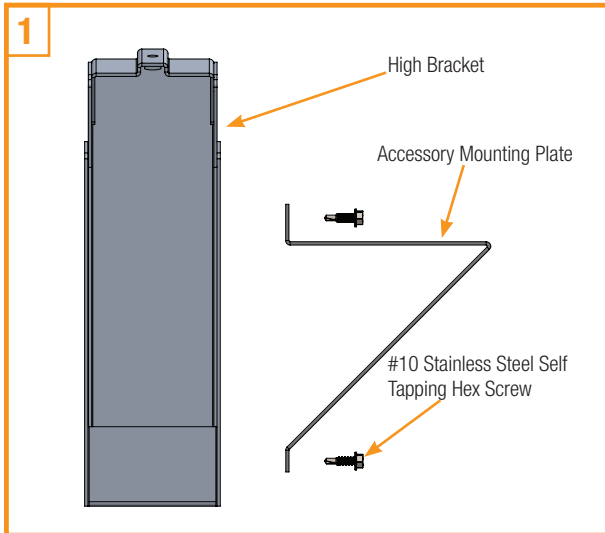

The Accessory Mounting Plate (AMP) should be attached to either side of the High Bracket using up to 4 x #10 Stainless Steel Self Tapping Sheet Metal Screws. When choosing a position on the bracket, make sure that placement of ballast blocks or panels won't interfere with the attachment or the accessories being mounted to the attachment.

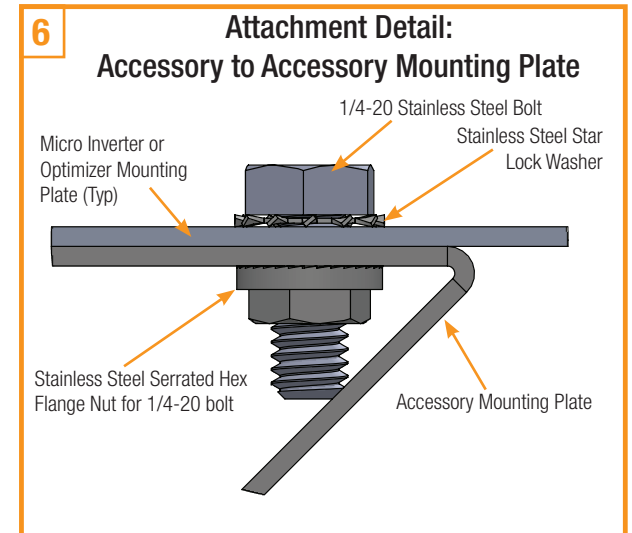
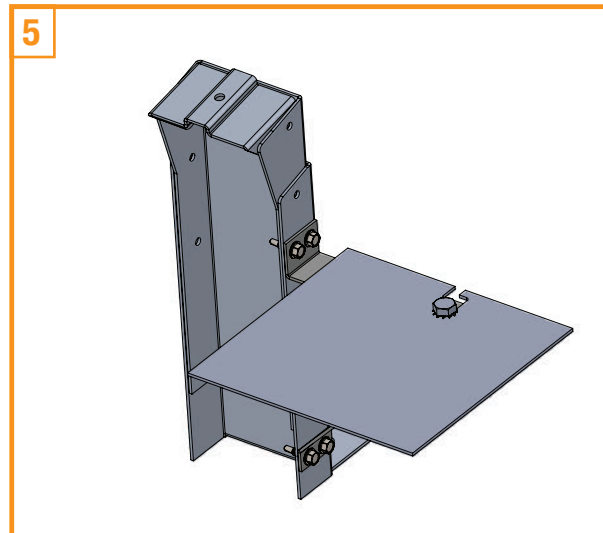
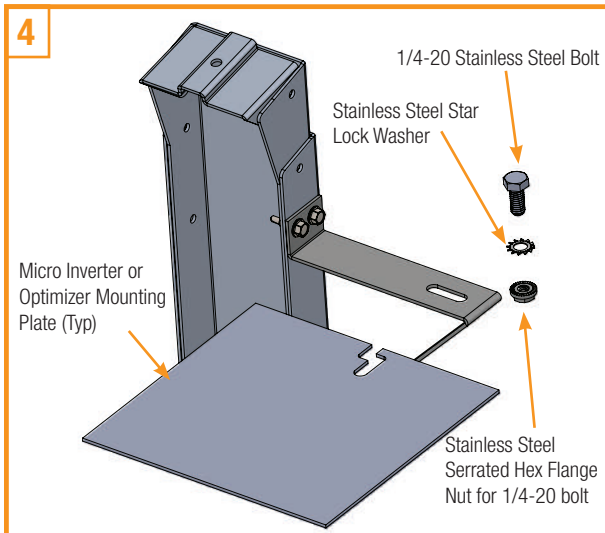

To attach an accessory to the AMP, use a 1/4-20 Stainless Steel Bolt with a Stainless Steel Star Lock Washer and a Stainless Steel Serrated Hex Flange Nut. Attach the accessory using the slot on the top of the AMP. tighten bolt to **65 in-lb**.

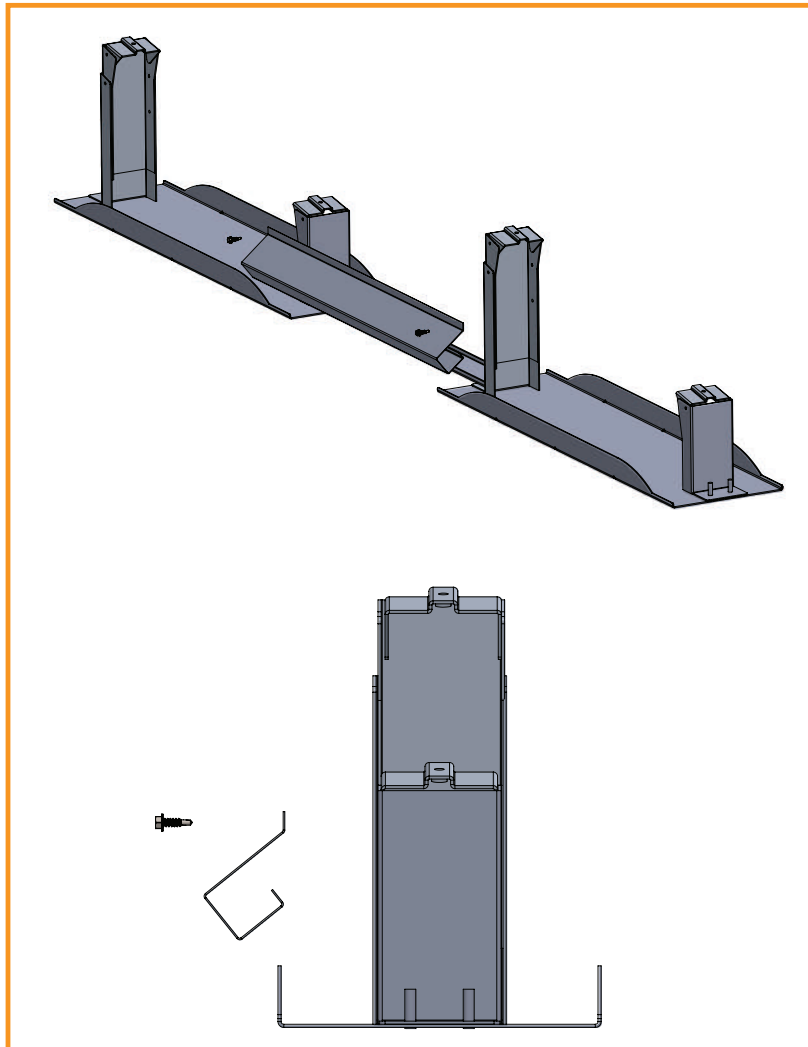

The Wire Management Raceway should be attached to the sides or back of the High Bracket or Low Bracket using #10 Stainless Steel Self Tapping Sheet Metal Screws. When choosing a position on the bracket, make sure that placement of ballast blocks or panels wont interfere with the attachment.

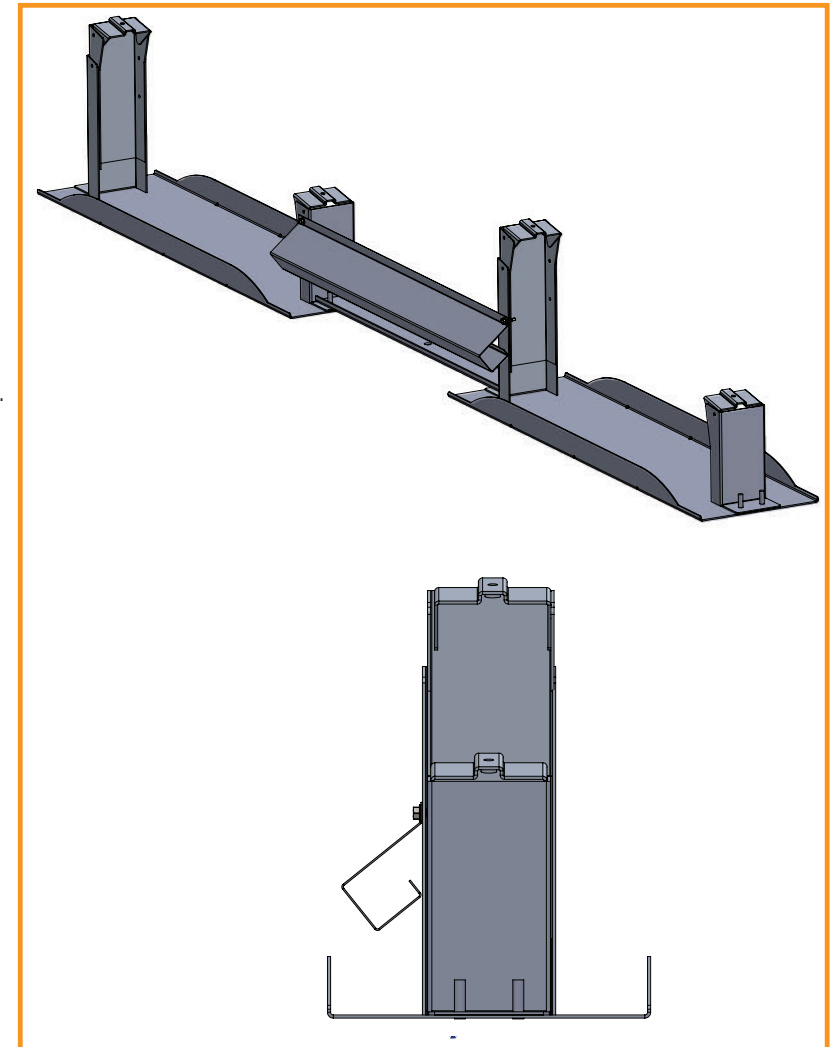

The Wire Management Raceway can be used to run conduit and wires both through an array and from one array to another.

ORION SOLAR RACKING

www.orionracking.com

info@orionracking.com

(310) 409-4616