

003607

Agreement



BY AND BETWEEN

LOS ANGELES COUNTY,
PUBLIC WORKS

AND

WARE DISPOSAL, INC.

FOR

THE EXCLUSIVE COMMERCIAL FRANCHISE CONTRACT FOR
THE AREA OF SAN GABRIEL VALLEY WEST (BRC0000246)



Part I

Contract

BETWEEN

COUNTY OF LOS ANGELES BOARD OF SUPERVISORS

AND

WARE DISPOSAL, INC.

FOR PROVISION OF COMMERCIAL SOLID WASTE COLLECTION SERVICES

(BRC0000246)

FOR THE SERVICE AREA OF

SAN GABRIEL VALLEY WEST

WITH A SERVICE COMMENCEMENT DATE AS EARLY AS

OCTOBER 1, 2022

TABLE OF CONTENTS

**FOR THE CONTRACT FOR THE SERVICE AREA OF
SAN GABRIEL VALLEY WEST (BRC0000246)**

SECTION 0 - RECITALS:..... 0-1

SECTION 1 - GRANT OF RIGHTS AND PRIVILEGES 1-4

 A. Requirements/Grant of Rights..... 1-4

 B. Exclusions from Service 1-4

 C. Exceptions from Exclusivity..... 1-9

 D. Fees to COUNTY 1-10

 E. Ownership of Solid Waste 1-10

SECTION 2 - TERM OF CONTRACT 2-11

 A. Term of Contract Services 2-11

 B. Obligations Upon Expiration or Termination of CONTRACT 2-12

 C. Undepreciated Assets 2-14

SECTION 3 - SCOPE OF SERVICES AND SPECIFICATIONS 3-15

 A. Prescribed Scope..... 3-15

 B. Change in Scope of Services 3-16

 C. Vehicles 3-16

SECTION 4 - SERVICE STANDARDS 4-21

 A. Public Health and Safety; Nuisances 4-21

 B. Private Property 4-22

 C. Non-Collection..... 4-23

 D. Compliance with Civil Rights Law 4-23

 E. CONTRACTOR Waste Reduction Practices..... 4-23

 F. Customer Correspondence and Other Materials..... 4-23

 G. Publicity and News Media Relations 4-24

 H. Responsiveness to County 4-24

 I. No Commingling of Solid Waste..... 4-25

 J. Key Personnel..... 4-25

 K. Uniforms..... 4-26

 L. Confidentiality..... 4-26

 M. Single-Pass Collection 4-27

 N. Professional Manner 4-29

 O. Privacy 4-29

SECTION 5 - ADDITIONAL CONTRACT PROVISIONS 5-30

SECTION 6 - CUSTOMER SERVICE 6-31

 A. Facilities 6-31

 B. Telephone Service 6-31

 C. Paperless/Electronic Information and Services..... 6-32

 D. Responses to Customer Complaints and Other Correspondence..... 6-34

 E. Service Interruption 6-35

F. Responsiveness to Customer 6-36

G. Setting Up or Terminating Service 6-36

H. No Evergreen 6-37

I. Term Limitation 6-37

J. No Charges 6-37

SECTION 7 - SERVICE RATES AND BILLING 7-38

A. Customer Service Rates 7-38

B. Customer Invoice and Payment 7-40

SECTION 8 - WASTE CHARACTERIZATION STUDY 8-43

A. Participate with County Study 8-43

SECTION 9 - RECORDS 9-44

A. Record Maintenance and Retention 9-44

B. County Custody 9-45

C. Inspection and Review of Records 9-45

D. Copies of Audits 9-46

E. Submission of Records 9-46

F. Public Record Request 9-46

SECTION 10 - REPORTS 10-48

A. Types and Content 10-48

B. Submission of Reports 10-55

C. Reporting Adverse Information 10-55

D. County's Right to Request Information 10-56

E. Reports of Cybersecurity Breaches 10-56

SECTION 11 - SUBSTITUTE, EMERGENCY AND BACK-UP SERVICE 11-57

A. Director's Right to Provide Contract Services 11-57

B. Customer Services - Response to Emergencies 11-59

C. Backup Service Plan 11-60

D. Use of Goods, Services and Property 11-62

SECTION 12 - ENFORCEMENT OF CONTRACT 12-64

A. As Provided by Law 12-64

B. COUNTY's Additional Remedies 12-64

C. Injunctive Relief 12-64

D. Recovery of Damages 12-65

E. County's Reimbursement Costs 12-67

F. Waiver 12-67

SECTION 13 - UNPERMITTED WASTE SCREENING AND REPORTING 13-68

A. Protocol 13-68

B. Prohibition on Collection 13-68

C. Notice to Director 13-68

D. Labels 13-68

SECTION 14 - EXECUTION OF CONTRACT 14-69

- A. Execution in Counterparts 14-69
- B. Authority to Execute 14-69
- SECTION 15 - PERFORMANCE ASSURANCE 15-70**
 - A. Performance Bonds, Other Security 15-70
 - B. Further Assurances 15-71
- SECTION 16 - CONTRACT SERVICE AREA INFORMATION 16-73**
 - A. Maps 16-73
 - B. Service Areas Data Information 16-73
 - C. Outreach 16-73
- SECTION 17 - CONTRACTOR DOCUMENTATION 17-74**
 - A. CONTRACTOR's Compliance with CONTRACTOR Documentation 17-74
 - B. Changes in CONTRACTOR Documentation 17-74

This exclusive franchise contract (CONTRACT) is made and entered into on _____, 2022, by and between COUNTY of Los Angeles Board of Supervisors, acting in their capacity as the governing body COUNTY of Los Angeles (COUNTY), and Ware Disposal, Inc., a California Corporation, located at 1035 East 4th Street, Santa Ana, California 92701, (hereinafter referred to as CONTRACTOR).

SECTION 0 - RECITALS:

Purpose. To limit the wear and tear on COUNTY streets, reduce pollution from Collection and Vehicle exhaust, increase customer service accountability, ensure compliance with Federal, State, and local laws, including Assembly Bills (AB) 341, 939, 1826, and Senate Bill (SB) 1383, by improving program implementation performance and reporting accuracy, and facilitate more efficient CONTRACT administration and enforcement by COUNTY staff.

Solid Waste Haul Permits. County of Los Angeles Department of Public Health issues permits to haulers for the hauling of Solid Waste with requirements to protect public health and safety, including frequency of Collection and Collection Vehicle maintenance. CONTRACTOR shall continue to obtain that permit and comply with all its provisions throughout the life of this CONTRACT; and

Mandatory Solid Waste Diversion. The State of California has found and declared that the amount of Solid Waste generated in California coupled with diminishing landfill space and potential adverse environmental impacts from land filling have created an urgent need for State of California and local agencies to enact and implement an aggressive, new integrated waste management program. Through enactment of AB 939, the State of California has directed agencies, such as COUNTY to Divert 50 percent of all Solid Waste through source reduction, recycling, and composting activities. The California Department of Resources Recycling and Recovery (CalRecycle) had granted COUNTY a timeline to achieve compliance with the AB 939 Diversion requirements to which COUNTY had met. Additionally, with the passage of Senate Bill 1383, COUNTY must comply with CalRecycle's requirements related to diversion of Organic materials such as Food Waste, Green Waste, and food-soiled paper, for the purpose of reducing short-lived climate pollutants such as methane and its impact on climate change. Non-compliance may subject the County to penalties and fines of up to \$10,000 per day. Continued compliance is based in part on executing and implementing this CONTRACT to secure cooperation with CONTRACTOR's AB 939 waste Diversion programs, record keeping, and reporting; and

County Zero Waste Plan. COUNTY Board of Supervisors adopted the Roadmap to a Sustainable Waste Management Future in 2014. It is a comprehensive plan for a waste free future and is a proactive approach to developing innovative policies for managing waste that further reduces COUNTY's reliance on landfills. It established the following intermediate and long-term disposal reduction targets: 80 percent Diversion from landfills by 2025, 90 percent Diversion from landfills by 2035, and at least 95 percent Diversion from landfills by 2045. The COUNTY updated the plan in 2021, referred to as the Zero Waste Plan; and

Municipal Solid Waste Discarded in Containers. The County has determined to provide for Municipal Solid Waste (MSW) Management Services in portions of Los Angeles County under the terms of this CONTRACT for reasons including the following:

- To enable businesses and residents located in the Service Area that discard Solid Waste in Dumpsters to receive quality MSW Management Services, and
- To provide COUNTY with programs, records, and reports that will help COUNTY comply with AB 939, AB 341, SB 1383, and other Laws.

Compliance with Law. CONTRACTOR shall perform Contract Services in accordance with all the Laws governing the safe Collection, transport, Recycling, and Disposal of Residential and Commercial Solid Waste, Including AB 939 and AB 341, SB 1383, Recovered Conservation and Recovery Act (RCRA), and Comprehensive Environmental Response Compensation and Liability Act (CERCLA).

CONTRACTOR / "Arranger". Under this Contract, COUNTY may exercise control over the Disposal or other disposition of the Solid Waste handled by the CONTRACTOR, commonly referred to as flow control. It may designate or determine the use of any given Solid Waste Facility. Although minimum scope of Contract Services, Service Specifications, and Service Standards are set forth in this CONTRACT, COUNTY has not, and by this CONTRACT does not, supervise Contract Services or assume title to Solid Waste; and

Competitive Procurement. COUNTY issued a Request for Proposals (RFP) or Invitation for Bids (IFB) to provide Contract Services under this CONTRACT. Private waste hauling companies submitted proposals or bids, including their proposed schedule of rates and charges. COUNTY selected the CONTRACTOR based, among other things, on CONTRACTOR's price proposal and work plan for Collection Services.

Compensation. The following describes the compensation allowed under this CONTRACT:

- Exhibit 7 provides for CONTRACTOR's compensation under Collection Services. Under this CONTRACT, the CONTRACTOR cannot charge its Customers more than the Customer Service Rates as stipulated in Attachment 7-2 Service Rates in Exhibit 7.
- Except as otherwise allowed under this CONTRACT, CONTRACTOR is not allowed to add any surcharges in addition to the fees that were entered on Form PW-2 and PW-3, Schedule of Prices. Any fuel, environmental, or other fees must be included in the original bid and may not be added later.

Franchise Authorization. PRC Section 40059 specifically authorizes COUNTY to prescribe the terms and conditions of Solid Waste management services, including:

- The nature, location, and level/extent of services;
- The frequency of Collection;
- The means of Collection and transportation;

- The Service Rates and fees; and
- Whether the services are to be provided by means of nonexclusive, partially exclusive, or wholly exclusive franchise, contract, license, permit or otherwise.

County Code Chapter 20.70 authorizes Director to require franchises in any part of the unincorporated territory of COUNTY that is not served by a Garbage Disposal District.

Franchise Development. COUNTY and representatives of the private hauling industry met many times to discuss the scope of services, service specifications, Service Standards, and other Performance Obligations and to address the industry's questions, comments, and concerns.

NOW, THEREFORE, THE PARTIES AGREE AS FOLLOWS:

This CONTRACT applies to all Contract Services, unless specifically indicated otherwise.

SECTION 1 - GRANT OF RIGHTS AND PRIVILEGES

A. Requirements/Grant of Rights

1. Grant of Rights and Privileges

COUNTY grants CONTRACTOR the right and privilege, together with the Performance Obligations, to provide Contract Services.

a. Conditions

- CONTRACTOR is ready, willing, and able to provide Contract Services;
- CONTRACTOR meets all its Performance Obligations,
- No CONTRACTOR Default has occurred as indicated in Part 3 of Exhibit 5; and
- CONTRACTOR fully and timely pays applicable Franchise Fees

b. CONTRACTOR Acceptance

CONTRACTOR accepts these rights and privileges together with Performance Obligations, subject to all terms and conditions in this CONTRACT and the exclusions in subsections B (Exclusions from Service) and C (Exceptions from Exclusivity) of this Section.

2. Grant of Exclusive Franchise for Collection Services

COUNTY grants to CONTRACTOR and CONTRACTOR accepts the exclusive right and privilege to provide Contract Services in accordance with its Performance Obligations, by making independent arrangements with County Commercial Franchise Customers as defined in item A1 of Exhibit 3A1, Collection may be primarily in Dumpster Containers, but may also include Carts and Roll-offs (excluding C&D) within the Service Area awarded to the CONTRACTOR as specified in this CONTRACT subject to all the terms and conditions in this CONTRACT and the exclusions in subsections B (Exclusions from Service) and C (Exceptions from Exclusivity) of this Section.

If a city annexes any portion of the Service Area, COUNTY shall replace the maps of the Service Area in item A1 of Exhibit 16 with new maps that reflect deletion of the annexed area on the date that the annexation becomes effective.

B. Exclusions from Service

Notwithstanding any provision to the contrary contained herein, the following are excluded from the right and privilege granted to CONTRACTOR under this Contract:

1. Solid Waste to be Self-Hauled

This CONTRACT excludes the right and privilege that CONTRACTOR Collect, transport, and Divert/Dispose Solid Waste that Persons Self-Haul. Anyone, including Persons performing services other than MSW Management Services (such as roofers and gardeners) at those Premises, may Collect in receptacles other than Container provided by CONTRACTOR, transport in their own Vehicles, and themselves Dispose of some or all the Solid Waste generated at those Premises.

2. Donation or Selling of Solid Waste or Edible Food

This CONTRACT excludes the right and privilege to Collect any Solid Waste materials or Edible Food that Occupant/Customer donates or sells to Persons other than CONTRACTOR.

3. Organic Waste Onsite Management

This CONTRACT excludes the right and privilege to Collect Organic Waste that Occupant manages on the site where it is generated, such as onsite Composting.

4. Micro-Haulers

This CONTRACT excludes the right and privilege to Collect Organic Waste that Occupant provides to COUNTY approved/contracted Micro-Hauler. The COUNTY allows Customers to utilize Micro-Haulers to Collect, transport, and Divert part or all their Organic Waste that they generate, including but not limited to the Collection of Manure, landscaping, and Food Waste.

Customers serviced by the Micro-Hauler will be transferred into the CONTRACTOR's franchise system if their weekly service level increases to more than the allowable service level under a Micro-Hauler of one 64-gallon Container of Organic Waste per week. The CONTRACTOR shall work with Micro-Haulers to transfer large Organic accounts into the franchise system when the Customers are located within their Service Area(s).

5. COUNTY and Third-Party Agencies

This CONTRACT excludes the right and privilege to provide Collection Services to Premises owned or controlled by any of the following entities:

- COUNTY or any other entity governed by the Board of Supervisors;
- State of California;

- Federal government;
- Any city;
- Any public-school district;

This CONTRACT does not prohibit CONTRACTOR from executing separate contracts with those entities to provide MSW Management Services.

If CONTRACTOR provides such services to any of the entities described above, CONTRACTOR shall report to COUNTY and include it in their Customer list report as indicated in item A1 of Section 10.

Additionally, the CONTRACTOR will not be required to pay the COUNTY any Franchise Fees for these Customers.

CONTRACTOR's failure to comply with any of the requirements of this Section may result in Liquidated Damages, in accordance with Exhibit 12-D2 Liquidated Damages.

6. Residential and Multifamily Premises with Carts Services

This CONTRACT excludes the right and privilege to provide Collection Services to Residential and Multifamily Premises (4 Units or Less) that receive services under an exclusive franchise awarded by the COUNTY for Cart service (such as an Exclusive Residential Franchise Contract for Provision of Refuse, Recyclables, and Green Waste Automated Cart Services at Residential Premises and Certain Multifamily Premises) which includes some mobile home parks. Additionally, the Director in its sole discretion may assign an Authorized Residential Franchise Waste Hauler to provide service to Multifamily Premises (5 Units or More) that have Carts service per individual unit and no Dumpsters.

However, this provision does not apply to Residential Premises who operate a business and utilize Carts for Collection Services. The Director may assign the Authorized Commercial Franchise Waste Hauler to provide service to these Customers.

Residential Customers with Carts and a business can be serviced by the Authorized Commercial Franchise Waste Hauler with Director approval.

7. Garbage Disposal District

This CONTRACT excludes the right and privilege to provide Collection Services to Premises that include Residential, Multifamily, and Commercial properties in a Garbage Disposal District. Garbage Disposal Districts are not included in the Service Area.

8. Non-Exclusive Commercial Franchise Customers

This CONTRACT excludes the right and privilege to provide Collection Services to Premises located in the Acton, Agua Dulce, and Antelope Valley (AV) areas, which shall remain under the non-exclusive commercial franchise system. The Acton, Agua Dulce, and AV areas are not included in the Service Area maps.

Additionally, this CONTRACT excludes the right and privilege to provide Collection Services to NBC Universal studios and their temporary shooting locations (off-site filming locations), which shall remain under the non-exclusive commercial franchise system.

9. Material Exceptions

The following types of materials are not subject to this CONTRACT and shall be designated as exempt materials. These exempt materials may be Collected and taken to a licensed Disposal site or Recycling facility by the Customer or Occupant of the Premises, or their agent, at the owner's or Occupant's expense, in accordance with COUNTY policy and Municipal Code requirements, with the exception of Construction and Demolition (C&D) Debris, which must be handled by a permitted waste hauler subject to requirements in County Code Chapter 20.87. Exempt materials include:

- Medical Waste
- Hazardous Waste
- Radioactive Waste
- Pharmaceutical Waste
- Construction and Demolition (C&D) Debris

10. Unauthorized Collectors

CONTRACTOR acknowledges and agrees that the COUNTY may permit other Persons besides CONTRACTOR to Collect any and all types of materials excluded from the scope of this CONTRACT, as set forth above, without seeking or obtaining approval of CONTRACTOR.

If CONTRACTOR can produce evidence that other Persons are servicing Collection Containers or are Collecting and transporting Solid Waste in a manner that is not consistent with this CONTRACT or the County Code, it shall report as indicated under item A3 of Section 10.

11. Rights Under California Public Resources Code Section 49520

a. *Exclusion*

This CONTRACT excludes the right and privilege for providing Contract Services with any Person who is receiving Solid Waste handling services from a Solid Waste enterprise that has the

statutory right to continue to provide Solid Waste handling services to that Person under PRC Section 49520 *et seq.*

b. Acknowledgements Regarding Statutory Rights

CONTRACTOR acknowledges:

(1) *No Statutory Rights*

CONTRACTOR affirms that it does not have any statutory rights under PRC Section 49520 *et seq.* that arise from providing services under this CONTRACT. This affirmation is not a relinquishment of any rights because no statutory rights exist.

(2) *Expired Term*

This CONTRACT is an exclusive franchise.

Upon expiration of this CONTRACT, no unexpired Term will remain. CONTRACTOR will have no right to continue providing Contract Services, MSW Management Services, or Solid Waste handling services under PRC Section 49520 *et seq.*

(3) *Terminated CONTRACT*

If COUNTY exercises its remedy to terminate this CONTRACT for CONTRACTOR fault, CONTRACTOR will have no right to continue providing Contract Services, MSW Management Services, or Solid Waste handling services under PRC Section 49520.

(4) *Contract Claims*

CONTRACTOR does not have the right to make any claim under PRC Section 49520, but only under this CONTRACT.

c. Stop Contract Services / Procure New Services

In accordance with PRC Section 49523, based on the mutually satisfactory terms of providing Collection Services set forth in this CONTRACT and receipt of compensation therefore, upon expiration or termination of this CONTRACT, CONTRACTOR shall stop providing Contract Services even if the expiration or termination occurs before the end of the period described in PRC Section 49520. In advance of, or upon expiration or termination of this CONTRACT, COUNTY may acquire one or more agreements for MSW Management Services with CONTRACTOR or other

Persons. Those agreements may be exclusive, partially exclusive, or wholly exclusive franchises, contracts, licenses, permits or otherwise, with or without competitive bidding.

CONTRACTOR Obligations Applicable to all Exclusions from Service

CONTRACTOR shall report to the COUNTY and maintain a record of all Customers located within their Service Area that qualify for exclusion of services such as Customers that Self-Haul or self-manage Organic Waste. Upon determining a Customer is Self-Hauling or self-managing their Organic Waste, the CONTRACTOR shall provide a written notice to the Customer informing them that they must register with the COUNTY as a Customer that Self-Hauls or self-manages Organic Waste, as applicable. The CONTRACTOR shall provide the written notice that is developed by the COUNTY.

C. Exceptions from Exclusivity

1. Emergency Services

This CONTRACT is not exclusive in regard to Collection of Solid Waste during emergencies, as described in Section 11. Under this Section, CONTRACTOR may be requested to perform work in other COUNTY Franchise areas, Garbage Disposal Districts, cities, or Counties. Likewise, other waste haulers may be requested to provide Solid Waste services within this Service Area. Service shall be provided at the same rate as the Customer Base Rates for Businesses. See Commercial Service Rates Schedule in Exhibit 7, Attachment 7-2.

2. Collection of Manure in Dumpsters at Residential Premises

This CONTRACT is not exclusive in regard to Collection, transportation, and Disposal/Diversion of Manure in Dumpsters discarded by either the Commercial Franchise or Residential Franchise Customers. Residential Customers that request Manure Dumpsters have the option to select Collection Services from either an Authorized Exclusive Commercial Franchise Waste Hauler or an Authorized Residential Franchise Waste Hauler. This applies to Manure-only Dumpsters for Residential Customers.

3. Collection of Construction and Demolition (C&D) Debris

This CONTRACT is not exclusive in regard to Collection, transportation, and Disposal/Diversion of Construction and Demolition Debris. Construction and Demolition Debris must be handled in accordance with the requirements in County Code Chapter 20.87 and by a hauler with all appropriate Public Health permits. Customers have the option to select any properly permitted Construction and Demolition Debris waste hauler as long

as the selected waste hauler has an agreement with the COUNTY to haul Construction and Demolition Debris.

D. Fees to COUNTY

In consideration for exclusive franchise rights granted under this CONTRACT, CONTRACTOR shall pay COUNTY the Franchise Fee at the time and in the amount and manner established from time to time by COUNTY ordinance or resolution of the Board of Supervisors. CONTRACTOR shall not separately identify the Franchise Fee in correspondence with Customers, including in Terms and Conditions, bills, or invoices.

CONTRACTOR acknowledges the following:

- The franchise fee is a consideration for the County's direct and indirect costs and expenses associated with the franchise rights granted under the Agreement.
- The elimination of competition with private persons for Contract Services under this exclusive franchise has significant monetary value to CONTRACTOR, and the franchise fee is consideration for that exclusivity.
- The franchise fee is a cost of doing business, like capital, fuel and labor costs.
- Paying COUNTY the franchise fee is an obligation of CONTRACTOR and not an obligation of Customers.

E. Ownership of Solid Waste

This CONTRACT does not purport to grant CONTRACTOR ownership over Solid Waste. The right to possession or ownership of Solid Waste placed at the Set-Out Site for Collection, Organic Waste (including Green Waste and Food Waste), Recyclables, and E-waste, will be determined in accordance with existing law and is not affected by this CONTRACT. COUNTY acknowledges that it has no ownership rights in Solid Waste and that CONTRACTOR may provide for transfer of ownership in the Terms and Conditions.

The COUNTY makes no representations or warranties with respect to content of Solid Waste, any Solid Waste Disposal characterization study, or projections by Solid Waste material type. COUNTY expressly disclaims any representations and warranties, either express or implied, as to the merchantability or condition of Solid Waste for any purpose.

CONTRACTOR will not make any claim against the COUNTY based on any estimates, statements or interpretations made by any officer, employee, agent, or consultant of the COUNTY in connection with the procurement of this CONTRACT, including the COUNTY's Request for Proposals, which differ from the actual under this Franchise.

SECTION 2 - TERM OF CONTRACT

A. Term of Contract Services

This CONTRACT is effective and binding on the Execution Date. It expires on the Expiration Date. Certain Performance Obligations survive expiration or termination of this CONTRACT under subsection B below.

“**Commencement Date**” is the first date of service: October 1, 2022.

“**Term**” is the period beginning on the Execution Date and ending on the Expiration Date.

“**Execution Date**” is the date both COUNTY and CONTRACTOR mutually sign this CONTRACT.

“**Expiration Date**” is any of the following days, as may be extended described in the following subsection A1 of this Section:

- September 30, 2032 in Contracts, or
- As earlier date that the Contract terminates in accordance with Part 6D of Exhibit 5.

1. Extensions of the CONTRACT Term

Director shall have the sole option to extend the initial Term of this CONTRACT under the following subsections A2, A3, and A4. CONTRACTOR may submit a request to the Director to not extend the Term of this CONTRACT. In such an event, the Director shall consider CONTRACTOR’s request and afford substantial weight in its decision to extend the term.

2. Three, 3-Year Extensions

Director may, in his sole discretion, extend the Term of this CONTRACT for up to three additional three-year periods.

3. Six, 1-Month Extensions

Director may, extend the Term of this CONTRACT up to six times, each time in an increment of one to 6 months for a total of no more than 6 months. For example, the Director may first extend the Term for 3 months, subsequently extend it for two more months, and lastly extend it for one more month.

4. Contract Extension Cumulative

The contract extensions are cumulative and may be exercised in any order. For example, after the end of the initial Term, Director may issue three 3-year extensions, one 3-month extension, followed by one 1-month extensions.

5. Transition to Next Waste Hauler

Certain obligations of CONTRACTOR survive the termination of this CONTRACT as provided under subsection B6 below.

6. Notification to CONTRACTOR

Director may notify CONTRACTOR of the intent to extend this CONTRACT no later than the following:

- 90 calendar days before a 3-year extension begins and 30 calendar days before an extension of any monthly duration.

B. Obligations Upon Expiration or Termination of CONTRACT

The following provisions will survive the expiration or termination of this CONTRACT:

1. Acknowledgements

All acknowledgments, including those in the following Sections:

- Item B of Section 1 (inapplicability of PRC 49520)
- Item C of Section 2 (no recovery of undepreciated asset value)
- Item A of Section 3 (no COUNTY responsibility for supervising or performing Collection Services)
- Item A of Section 9 (Record maintenance)
- Part 6 of Exhibit 5 (interpretation of this CONTRACT)

2. Representations and Warranties

All representations and warranties, including those made in accordance with the following Sections:

- Part 6 of Exhibit 5 with respect to review of this CONTRACT
- Item B of Section 14, Authority to Execute
- Attachment 5-8H, CONTRACTOR's Representations and Warranties

3. Indemnities

All Indemnities.

4. Payments

All obligations to pay any due and payable monetary amounts or requests for those amounts, including:

- Payment of Transfer Deposits and Transfer Costs
- Damages under item D of Section 12
- Refund due to Customers that pay Customer Service Rates in advance of Customer Service
- Any Franchise Fees

5. Records and Reports

All obligations to maintain and submit Records and Reports, including:

- The final Annual Report
- Information with respect to Solid Waste Facilities
- Copies of certificates of insurance or other evidence of coverage
- Records of Disposal
- Notice of Destruction of Records of Disposal
- Inspection and audit
- Copies of education and outreach completed
- Records of Non-Collection Notices including supporting documentation

6. Provisions Surviving Expiration Date

Any other provisions of this CONTRACT and rights and obligations of the Parties stated to survive the Expiration Date, including:

- This subsection B6 (cooperation during transition; removal of Containers), and
- Subsection C (no recovery of undepreciated asset value).

a. Cooperation During Transition

If CONTRACTOR is not awarded a new CONTRACT to allow CONTRACTOR to continue to provide MSW Management Services substantially similar to Contract Services in this Service Area after the expiration or termination of this CONTRACT, CONTRACTOR shall cooperate fully with Director and the succeeding contractor, licensee, permittee, or other provider of MSW Management Services to assure a smooth, efficient, orderly, timely, and effective transition.

b. Transfer or Removal of Containers

(1) If County Exercises Container and/or Cart Lids Purchase Options

If upon expiration or termination of this Collection CONTRACT the COUNTY purchases any or all Containers and Cart lids under item C10 of Exhibit 3A1, CONTRACTOR will transfer ownership of those Containers and Carts to COUNTY with documentation satisfactory to COUNTY no later than 7 days after the expiration or termination.

(2) If County Does Not Exercise Container and/or Cart Lids Purchase Options

If upon expiration or termination of this Collection CONTRACT the COUNTY does *not* purchase any or all Containers and Cart lids under item C10 of Exhibit 3A1, then the CONTRACTOR will remove remaining Containers on COUNTY request no later than the following dates:

(a) The date Customers receive replacement Containers,

or

(b) 2 months after the expiration or termination of this Collection CONTRACT.

7. Container Purchase Option

COUNTY may purchase Containers as specified in item C10 of Exhibit 3A1.

C. Undepreciated Assets

If any of CONTRACTOR's Service Assets remain undepreciated upon the expiration or earlier termination by COUNTY of this CONTRACT, CONTRACTOR has no right to recover amounts equal to the undepreciated asset value from COUNTY or Customers, and neither COUNTY nor Customers are obligated to compensate CONTRACTOR for any undepreciated asset value.

CONTRACTOR acknowledges that when exercising its option to extend the Expiration Date, COUNTY need not consider whether any Service Assets are not fully depreciated as of the Expiration Date, and that CONTRACTOR invested in and depreciated those Service Assets in CONTRACTOR's sole discretion.

SECTION 3 - SCOPE OF SERVICES AND SPECIFICATIONS

A. Prescribed Scope

1. Collection Services

CONTRACTOR shall provide Contract Services in accordance with Exhibit 3A1 to the following Premises in the Service Area:

- Premises in the Service Area that were (1) receiving service up to the Execution Date from a non-exclusive Franchisee under a COUNTY Franchise for Non-Exclusive Commercial Solid Waste Collection Services, and (2) included in CONTRACTOR's franchise grant under this Collection CONTRACT, such as Commercial Premises, *unless* and *until* they un-subscribe from Contract Services and
- Upon request, Premises in the Service Area that are (1) not receiving Solid Waste handling services on the Execution Date but (2) are included in CONTRACTOR's franchise grant under this Collection CONTRACT, including Commercial Premises, and (3) subscribe to Contract Services.

2. General

Contract Services include providing Goods, Services, and Property necessary to meet Performance Obligations, including:

- Labor and supervision;
- Software and hardware, including Records of Customer subscription and complaints, billing, and routing, and system utilized by Director to track Collection Services;
- Leases; subleases; installment purchase agreements, including with respect to Vehicles and Carts;
- Equipment, including Vehicles, Carts, or other Containers (such as for special events);
- Supplies; such as plastic bags and cardboard boxes for community cleanup projects and/or special events.
- Insurance, bonds, or other performance security if the insurer, surety, or another provider is an Affiliate or a captive of CONTRACTOR or any Affiliate;
- Maintenance and Office-administration facilities, and their contents,
- Legal, risk management, general, and administrative services.

CONTRACTOR must provide Contract Services in accordance with Service Specifications and Service Standards. Nevertheless, CONTRACTOR has the freedom and discretion to determine the means, manner, or method of providing Contract Services.

CONTRACTOR acknowledges that in entering into this CONTRACT, COUNTY is not responsible for supervising CONTRACTOR or for performance of any Contract Services.

CONTRACTOR shall choose the Solid Waste Facilities, unless otherwise directed by COUNTY as referenced in item D of Exhibit 3A1. In addition, COUNTY is not the owner or titleholder of any material Collected, transported, Disposed of, or otherwise handled by CONTRACTOR.

Any work performed outside the Performance Specifications without Director's prior written approval will be deemed to be a gratuitous effort by CONTRACTOR. CONTRACTOR shall have no claim against COUNTY for any consequential or related liabilities.

B. Change in Scope of Services

1. Collection Services

Director may change the scope of Collection Services and Service Standards in accordance with Part 5 of Exhibit 5, subject to any adjustment in the Customer Service Rates in accordance with item A of Section 7.

2. Service Area Boundary

The Director may adjust Service Area boundaries to account for new development near the Service Area. CONTRACTOR may request a Rate Adjustment only if a boundary results in greater than 10% change of the Service Area's total weekly service level or if such adjustment otherwise impacts CONTRACTOR's costs or expenses in providing the Collection Services under this CONTRACT.

C. Vehicles

1. General

CONTRACTOR shall use Vehicles of appropriate numbers, sizes, capacities, and functions required for the efficient Collection of different types of Solid Waste, such as Refuse, Recyclables, Organic Waste, and Bulky Items. CONTRACTOR shall also provide non-compacting Vehicles for the Collection of E-waste, white goods and any other material that contains chlorofluorocarbons. Vehicles shall be so constructed such that Solid Waste or liquids will not blow, fall, sift, or leak out of the truck into the street. CONTRACTOR shall equip Vehicles with a shovel, broom, and petroleum absorbent agents.

CONTRACTOR shall comply with all local, state and federal Laws, regulations and requirements such as vehicle, engine and fuel standards, including, but not limited to, South Coast Air Quality Management District Rule 1193 and any Laws, rules and regulations superseding it.

CONTRACTOR shall comply with any additional requirement with respect to the Vehicles as set forth in this Section.

2. Alternative Fuel Vehicles

By 2025, all Vehicles used for automated Collection must use Liquid Natural Gas or Compressed Natural Gas fuel, or other alternatives to diesel fuel, as approved by Director unless Contractor Documentation provides otherwise with respect to Collection at Premises that are difficult to serve as described in item L of Exhibit 3A1.

3. Automation

CONTRACTOR shall Collect Refuse, Recyclables, and Organic Waste in automated Collection Vehicles, except CONTRACTOR may Collect the following materials in non-automated Collection Vehicles:

- a. Bulky Items including E-waste**
- b. Holiday trees**
- c. Solid Waste discarded at Set-Out Sites that are Difficult to Service**

4. Renewable Natural Gas (RNG) Procurement

CONTRACTOR shall procure RNG derived from recycled Organic Waste that meets SB 1383 regulations Section 18993.1(h) requirements in the amount of, at least, 25% of their total fuel usage for servicing their Service Area when RNG becomes adequately commercially available for use in California.

CONTRACTOR shall agree that the COUNTY has the sole right to report this RNG procurement towards the COUNTY's fulfilment of its annual recovered Organic Waste product procurement target defined in accordance with 14 CCR Section 18993.1.

CONTRACTOR shall maintain records of all fuel contracts and purchases and provide to COUNTY upon request in addition to fulfilling reporting requirements stipulated under item A2 of Section 10 Reports. CONTRACTOR will be exempt from this requirement if fuel equivalency used for CONTRACTOR's Collection Vehicles exceeds 75% electric. If CONTRACTOR's fuel equivalency used exceeds 75% electric, then

CONTRACTOR's remaining non-electric fuel usage shall be SB 1383 eligible RNG.

CONTRACTOR may propose an alternative procurement plan, as listed in item J4 of Exhibit 3A1, with justification for why RNG procurement is not feasible or reasonable, provided the plan meets the RNG equivalent of 25% total fuel usage and the requirements of SB 1383, Article 12, Section 18993.1(h). Implementation of such plan is subject to COUNTY approval.

5. Extra Vehicles

CONTRACTOR shall maintain enough back-up Vehicles to replace similar types of Vehicles in the event of breakdowns, complaints, and emergencies. Director may specify a minimum number of backup Vehicles.

6. Scales

Within 6 months of Director's request, all automated Collection Vehicles are to have the ability to weigh each Container as it Collects from each Occupant's Set-Out Site. This data is to be connected to each service address and submitted upon Director's request.

7. Vehicle Maintenance

CONTRACTOR shall maintain Vehicles reasonably clean, and in good mechanical condition, and well painted, all to the satisfaction of Director. CONTRACTOR shall maintain Records of inspections and maintenance of all mechanical equipment that CONTRACTOR uses to provide Contract Services, including Vehicles. CONTRACTOR will use Vehicles that are safe to operate, in accordance with the requirements promulgated by COUNTY Department of Public Health, California Highway Patrol, South Coast Air Quality Management District, manufacturer, and all other applicable Federal, State, County, and local laws and regulations. CONTRACTOR shall allow Director to view all inspection and maintenance Records and shall provide Director with those Records upon request.

CONTRACTOR is not required to provide new Vehicles on the Commencement Date or to retire Vehicles of any specified age. However, CONTRACTOR shall not operate Vehicles that repeatedly breakdown or leak. CONTRACTOR shall replace a Vehicle that Director determines to be of unsatisfactory operating condition, such as one that is frequently breaking down and delaying services, leaking fluids, making excessive noise, or exhibiting other significant issues identified by Director.

8. Safety Equipment

All Collection equipment used by CONTRACTOR shall have appropriate safety markings including, but not limited to, highway lighting, flashing and

warning lights, clearance lights, and warning flags. All such safety markings shall be subject to the approval of COUNTY (if different from the markings commonly used by CONTRACTOR) and shall be in accordance with the requirements of the California Vehicle Code, as may be amended from time to time. All Collection Vehicles shall be equipped with audible back-up warning devices.

9. Vehicle List

CONTRACTOR shall use only Vehicles that have been submitted to and approved by the Director. CONTRACTOR shall submit a complete list of Vehicles, including back-up Vehicles, using the applicable reporting form, accessible through LA County's Data Management System and update it as Vehicles change.

10. Vehicle Billboards

CONTRACTOR shall equip automated Collection Vehicles with frames on both sides capable of securing signs measuring approximately 30 inches by 90 inches or another dimension approved by Director. CONTRACTOR shall design, print, and install signs on each frame promoting Recycling of Recyclable materials and Organic materials, Diversion and safe handling of Unpermitted Waste or other topics as requested by Director, with text, graphics, and design approved by Director, up to six times throughout the CONTRACT term. CONTRACTOR shall ensure that the appropriate Director-approved signs are affixed to the Vehicle always. Director reserves the right to interchange any of the six signs up to four times per Contract Year. CONTRACTOR shall not use the billboards for commercial advertising.

11. Vehicle Identification

CONTRACTOR's name or other name, as approved by Director, Vehicle identification number and logo shall appear on all Vehicles.

Collection Vehicle Technology All Vehicles used for Collection Services, shall be equipped with a Global Positioning System (GPS). GPS data will be maintained by CONTRACTOR either directly or through a third-Party service. The GPS shall be able to track a Vehicle's route with lines or dots superimposed on a map.

12. Global Positioning System (GPS)

All Vehicles used for Collection Services, shall be equipped with a Global Positioning System (GPS). GPS data will be maintained by CONTRACTOR either directly or through a third-Party service. The GPS shall be able to track a Vehicle's route with lines or dots superimposed on a map.

The GPS shall gather the following data: date, time, speed, direction, location (address) and shall be able to generate Reports. CONTRACTOR shall retain all data for a minimum of 30 calendar days or other duration approved by Director.

The minimum (ping frequency of occurrence that GPS data is received from the Vehicle) shall be at least every one minute for fully automated Collection and at least every ten seconds for other Collection Vehicles, when within the Service Area.

CONTRACTOR may propose an alternate tracking system or device that results in similar results and data for Director approval.

CONTRACTOR must provide to Director at no additional cost or expense any software or licenses required to view recording or data. Director may request Reports from CONTRACTOR to track the location of Collection Vehicles in real time and to generate Reports as needed. CONTRACTOR shall provide copies of Reports within two business days of receiving Director request. Request may be for a specific time or a geographic location (e.g., between 10:00 a.m. and 11:00 a.m., or 1200 block of Main St.). CONTRACTOR's failure to provide Reports requested by Director within time specified by Director may be considered an admission of fault for the purposes of assessing Liquidated Damages. For example, if CONTRACTOR does not give Director a requested Report, within a period specified by Director, to verify that a Vehicle Collected all Containers on an identified block, Director may assume that CONTRACTOR did not Collect those Containers and assess Liquidated Damages.

SECTION 4 - SERVICE STANDARDS

A. Public Health and Safety; Nuisances

CONTRACTOR shall immediately Report to Director any public health and safety or nuisances listed below.

1. Litter

CONTRACTOR shall immediately clean up all litter it caused. If CONTRACTOR services an over-filled Container where the lid cannot be closed, any litter must be cleaned.

When Collecting any Bulky Items, CONTRACTOR shall also clean up all litter within a 3-foot radius of the site from which CONTRACTOR Collected the Bulky Item. CONTRACTOR shall ensure that each Vehicle is properly staffed and equipped for this purpose.

2. Spills

CONTRACTOR shall enclose or cover Solid Waste that it transports in Vehicles, debris boxes, hoppers, compactors, or any other Containers. CONTRACTOR shall prevent Solid Waste from escaping, dropping, spilling, leaking, blowing, sifting, falling, or scattering from Vehicles ("Spills") during Collection and transportation. CONTRACTOR shall not transfer loads from one Vehicle to another Vehicle unless necessitated by mechanical failure or accidental damage to a Vehicle. CONTRACTOR shall immediately clean up any Spills on any alley, street, or public place.

3. Leaking

CONTRACTOR shall prevent oil, hydraulic fluid, paint, or other liquid from leaking from its Vehicles. CONTRACTOR shall ensure that each Vehicle carries petroleum absorbent agents and other appropriate cleaning agents and if any liquid leaks from a Vehicle, CONTRACTOR shall immediately cover, treat, or remove the liquid materials from the ground, as necessary, and apply the necessary cleaning agent to minimize the adverse impact of the liquid materials.

4. Noise

CONTRACTOR shall conduct Collection as quietly as possible, in compliance with noise levels prescribed by Applicable Law, including County Code Section 12.08.520-Refuse Collection Vehicles. CONTRACTOR shall cause the least possible obstruction and inconvenience to public traffic or disruption to the peace and quiet of the Service Area.

While on Residential streets, CONTRACTOR shall minimize the noise for horses in the Public Right-of-Way. The Collection Vehicle shall park and not operate the Collection arm or compact the load while within 100 feet of a horse that is walking in the Public Right-of-Way.

5. Best Management Practice

CONTRACTOR shall implement the following best management practice. When CONTRACTOR services a Container, CONTRACTOR shall ensure the Container lid is closed prior to returning it back to its designated Set-Out Site.

B. Private Property

CONTRACTOR shall obtain property owner consent to enter private driveways, alleys, streets, and parking lots in cases such as:

1. Private Property

a. Acknowledgements

CONTRACTOR acknowledges the following: Although there may be an implied waiver to access the front of Premises, a written consent may be advisable to access a side or rear yard. Additionally, private streets and driveways may not meet COUNTY's design standards and may not adequately withstand the weight of a Collection Vehicle.

b. Damage to Pavement: Waiver

If CONTRACTOR operates Vehicles on private property, following Director approval, CONTRACTOR may require the property owner to allow CONTRACTOR's entry and waive liability for CONTRACTOR's damage to driveways or other pavement, in a form satisfactory to Director. CONTRACTOR is not obligated to require a waiver. A waiver will not relieve CONTRACTOR of its obligation to repair or replace damaged pavements if it caused the damage by its negligent or willful acts or omissions under Part 9C of Exhibit 5.

c. Personal Injury: Indemnity

If CONTRACTOR enters private property whether in a Vehicle or by foot (for example to provide roll-out service), following Director approval, CONTRACTOR may require the property owner to hold harmless and indemnify CONTRACTOR in form satisfactory to Director. In that event, CONTRACTOR shall also require the property owner to hold harmless and indemnify COUNTY.

d. CONTRACTOR Indemnifies COUNTY

Despite receiving COUNTY approval, CONTRACTOR shall indemnify and hold COUNTY harmless from liabilities related to entering Customers' Premises, whether CONTRACTOR acts in compliance or noncompliance with this Contract. This indemnification is in addition to CONTRACTOR's other Indemnifications.

C. Non-Collection

CONTRACTOR is not obligated to Collect in any of the following events prescribed in item A5 of Exhibit 3A1.

D. Compliance with Civil Rights Law

CONTRACTOR shall comply with Subchapter VI of the Civil Rights Act of 1964, 42 USC Sections 2000 (e)(1) through 2000 (e)(17), to the end that no person shall, on the grounds of race, creed, color, sex, religion, ancestry, age, condition of physical disability, marital status, political affiliation, or national origin, be excluded from participation in, be denied the benefits of, or be otherwise subjected to discrimination under this Contract or under any project, program, or activity supported by this Contract. Contractor shall comply with its EEO Certification (Form PW-7).

E. CONTRACTOR Waste Reduction Practices

Consistent with the Board of Supervisors' policy to reduce the amount of Solid Waste Disposed in landfills within COUNTY, CONTRACTOR shall use best efforts to practice waste reduction and implement procurement policies in providing Contract Services, including maintaining Records. In written correspondence with Customers and Director, CONTRACTOR shall use recycled paper that is labeled to indicate its recycled content.

CONTRACTOR shall offer Customers the option to go paperless by offering them electronic notifications.

F. Customer Correspondence and Other Materials

CONTRACTOR shall submit to Director for approval, written materials CONTRACTOR intends to distribute to Customers at least thirty County Business Days before printing, texting, e-mailing, or mailing the materials.

At Director's request CONTRACTOR shall distribute written information to its Customers and Occupants by including it within CONTRACTOR's mailings or by separate electronic distribution.

G. Publicity and News Media Relations

1. Publicity

Unless otherwise required by subsection F or subsection G.2, CONTRACTOR and its Affiliates, employees, consultants, agents, or subcontractors may, without Director approval, publicize its Contract Services or indicate in its proposals and sales materials that it has been awarded this CONTRACT to provide Contract Services, if CONTRACTOR develops that publicity, proposals, or sales materials in a professional manner.

Neither CONTRACTOR nor any of its Affiliates, employees, consultants, agents, or Subcontractors may publish or disseminate commercial advertisements, news or press releases, opinions or feature articles using the name of COUNTY without the prior written consent of COUNTY's Chief Executive Officer and County Counsel.

2. News Media Relations; Trade Journal Articles

CONTRACTOR shall notify Director by telephone followed by e-mail of all requests for news media interviews related to the Contract Services (and not other communities) within 24 hours of receiving the request. Before responding to requests involving matters other than the Collection programs and scope of Contract Services, CONTRACTOR shall discuss CONTRACTOR's proposed response with Director.

CONTRACTOR shall submit copies of CONTRACTOR's draft news releases or proposed trade journal articles related to Contract Services to Director for prior review and approval at least four County Business Days in advance of release.

CONTRACTOR shall give Director copies of media interviews and news releases related to Contract Services within four County Business Days of their occurrence.

H. Responsiveness to County

CONTRACTOR shall meet the following standards:

1. Normal

Respond to COUNTY communications such as telephone messages, text messages, and e-mails no later than the next COUNTY Business Day. Acknowledge, at a minimum, that the CONTRACTOR has received the communication and provide an estimated time for a full response if the communication's issue cannot be immediately resolved.

2. Emergency Telephone Messages

Respond to any telephone message within one hour in cases of emergencies as required under item J1 of Section 4.

3. Written Correspondence

Respond to written correspondence from Director within one week of receipt.

4. Meetings

Meet with Director during Director's Office Hours within one week of Director's oral or written request at Director's offices or other location requested by Director.

I. No Commingling of Solid Waste

1. No Commingling Between Areas

CONTRACTOR may not commingle, in its Vehicles or otherwise, any Solid Waste that it Collects within the Service Area with any other Solid Waste that it Collects outside the Service Area, without prior written approval from Director.

For example, Director may allow Food Waste to be Collected from multiple jurisdictions to make Collection routes more efficient and therefore more cost effective. Additionally, Director may consider allowing commingling of Solid Waste during emergency situations.

Director may require documentation such as records of Customers, including Container capacities, in cities and in the Service Area, respectively. CONTRACTOR shall maintain Records with respect to Solid Waste Collected in the Service Area separately from records with respect to Solid Waste Collected outside the Service Area, including its weight.

2. No Commingling of Different Materials

CONTRACTOR shall not commingle, in its Vehicles or otherwise, any Solid Waste that it Collects with any other type of Solid Waste that it Collects within the Service Area, without prior written approval from Director, as detailed in item M of this Section and further required in item E4 of Exhibit 3A1. For example, if a Vehicle is on its route Collecting Refuse, it may not Collect Recyclables or Organic Waste until after it has emptied its Refuse load at the approved facility.

J. Key Personnel

CONTRACTOR acknowledges that it identified certain personnel and described their professional experience and qualifications in the proposal it submitted to Director about the procurement of this CONTRACT, and that COUNTY awarded this CONTRACT to CONTRACTOR based in part on those individuals' experience and qualifications. CONTRACTOR shall identify those personnel ("Key Personnel") in Contractor Documentation in Exhibit 17.

CONTRACTOR shall notify Director immediately of changes or upcoming changes in Key Personnel, including the professional experience and qualifications of the individual CONTRACTOR proposes to serve in place of a departing Key Personnel. Director may request CONTRACTOR to propose an alternative individual to serve in the position of the departing Key Personnel.

1. Emergency Telephone Number

CONTRACTOR shall maintain a local emergency telephone number disclosed to Director for use by Director outside CONTRACTOR Office Hours. CONTRACTOR shall make a representative available at the emergency number outside CONTRACTOR Office Hours who will return any emergency call as soon as possible and in any event within one hour.

2. Lead Person

CONTRACTOR shall assign a lead person(s), such as a route supervisor, to this Service Area. The lead person shall be responsible for ensuring that CONTRACTOR meets Performance Obligations. They shall spend as much time as possible in the Service Area. They shall act as a liaison between field crew and Director.

K. Uniforms

CONTRACTOR shall require its field employees to wear uniforms and prohibit them from removing any portions of their uniforms while providing Contract Services. Uniforms must meet the following specifications:

- Bear the CONTRACTOR's name, or other name approved by Director (for example, a DBA instead of a corporate name), and
- CONTRACTOR's logo.

L. Confidentiality

CONTRACTOR shall maintain the confidentiality of all records obtained from Director under this CONTRACT in accordance with all Applicable Law. CONTRACTOR shall inform all its officers, employees, agents, and Subcontractors providing Contract Services of this confidentiality obligation. CONTRACTOR acknowledges that these records may be subject to a Public Records Request made to COUNTY.

M. **Single-Pass Collection**

CONTRACTOR shall obtain Director's approval prior to implementing single-pass service. "Single-pass service" means that Customers may commingle and discard Refuse, Recyclables, and Organic Waste, and CONTRACTOR may Collect them in the same Container. If CONTRACTOR implements single-pass service, it shall remove or replace the additional Collection Containers designated for Recyclables and Organic Waste from the Customer's Premises.

CONTRACTOR must separate those commingled Solid Waste materials at a High Diversion Organics Waste Processing Facility (HDOWPF) that complies with SB 1383 requirements and Divert them. CONTRACTOR shall maintain weight Records of commingled Solid Waste separately from weight Records of source-separated Solid Waste.

1. **Approval**

If a Customer requests the single-pass service, CONTRACTOR shall request single-pass service for such Customer(s). CONTRACTOR may request single-pass service on behalf of Customer(s) if they consider Customers would benefit from this service. Requests must be approved by the Director and include the following:

- Proposed Customer(s) address(es), and service level(s)
- Written justification of the total miles of the entire route to provide this service
- Written consent from Customer(s) affected by the single-pass, and
- Notification to Customer(s) residing on the Premises being serviced.

2. **Billing Fees**

If approved by Director, CONTRACTOR must charge Customers the total cost of providing this service. The billing fees shall be separated into two expense components.

- Disposal/Diversion Expense -This is the expense related to processing all the waste Collected through single-pass. This is the tip fee (\$ per ton) at the HDOWPF multiplied by the total single-pass Tonnage.
- Transportation Expense - This is the added expense related to sending one special truck from CONTRACTOR's yard to the Service Area and then to the HDOWPF. This expense shall be identified as a cost per mile as stipulated in Attachment 7-2, Service Rates of Exhibit 7. At the time of implementation, CONTRACTOR shall provide justification of the total miles of the entire route to implement

the single-pass option. The total expense shall be the cost per mile multiplied by the total miles. The Director may assign differing percentages for distributing this expense among the customers if distance varies greatly to serve one Customer versus the other.

Contractor shall add the Disposal/Diversion Expense and the Transportation/Labor Expense for a total cost of implementation. Rates charged to Customer(s) shall be the total cost of implementation divided by total cubic yards serviced of all Dumpsters and/or Carts within the single-pass option, and then multiplied by each Customer(s) cubic yard single-pass service for their individual rate.

For example:

- 2 large Customers are approved for single-pass service
 - Customer A will have 40 cubic yards service
 - Customer B will have 80 cubic yards service
- CONTRACTOR identifies total tonnage collected is 15 tons (via weigh tickets) and tip fee is \$110/ton = \$1650
- CONTRACTOR identified \$10/mile and total single-pass route is 20 miles = \$200
- Customer A rate = $\$1850/120\text{CY} \times 40\text{CY} = \616.66
- Customer B rate = $\$1850/120\text{CY} \times 80\text{CY} = \1233.33

3. Customer Billing

CONTRACTOR shall invoice single-pass Customers quarterly. CONTRACTOR must ensure they accurately bill Customers for all services provided. CONTRACTOR must provide Customers a 30-day notice prior to changing any billing rates.

N. Professional Manner

The services provided by CONTRACTOR shall be performed in a thorough and professional manner so that all Customers are provided at all times with reliable, courteous and high-quality Solid Waste handling services. To determine what is “professional” COUNTY may consider policies, standards, recommendations and other statements from associations whose members handle Solid Waste, such as the Solid Waste Association of North American (SWANA), the National Waste and Recycling Association, Association of County Engineers.

O. Privacy

1. General

CONTRACTOR shall strictly observe and protect the rights of privacy of Customers and Occupants. CONTRACTOR shall not reveal to a Person other than COUNTY any information identifying individual Customers and Occupants or the composition or contents of a Customer's Solid Waste to any Person unless under Section 9 or upon the authority of Law or upon valid authorization of the Customer. This provision may not be construed to excuse CONTRACTOR from its obligations to assist COUNTY in the preparation of Solid Waste characterization studies or waste stream analyses, keeping Records, making Reports, or assisting COUNTY on meeting Federal, State, and local requirements.

2. Mailing Lists

CONTRACTOR shall not market or distribute mailing lists with the names and addresses of Customers and Occupants.

3. Privacy Rights Cumulative

CONTRACTOR's obligations in this Section are in addition to any other privacy rights accorded Customers and Occupants under Applicable Law.

SECTION 5 - ADDITIONAL CONTRACT PROVISIONS

Exhibit 5 contains additional CONTRACT provisions that are incorporated by reference into the CONTRACT. Exhibit 5 includes the following parts:

- Part 1 General CONTRACT Requirements
- Part 2 Indemnification and Insurance
- Part 3 Suspension; Termination; Debarment Breaches and Defaults
- Part 4 Transfer of CONTRACT
- Part 5 General Provisions
- Part 6 Definitions and Interpretations of CONTRACT
- Part 7 Compliance with Laws and Regulations
- Part 8 Labor-Related Provisions Required in County Contracts

SECTION 6 - CUSTOMER SERVICE

A. Facilities

CONTRACTOR shall maintain both the following:

- A Vehicle maintenance yard, and
- Office at the address provided in Contractor Documentation in Exhibit 17.

CONTRACTOR may change the address by notifying Director in accordance with item A5 of Exhibit 17.

B. Telephone Service

CONTRACTOR shall maintain a toll-free telephone number and meet the following criteria:

1. Office Hours

CONTRACTOR shall provide a customer service representative to personally answer all calls to the toll-free number during CONTRACTOR Office Hours, including calls from Director, Customers, Occupants, and the public.

2. After Hours

CONTRACTOR shall provide an answering machine to answer all calls to the toll-free number outside of CONTRACTOR Office Hours that allows callers to leave messages, such as reporting missed pick-ups and other complaints. CONTRACTOR shall further comply with County Code Section 20.72.160.

3. On Hold Messaging

CONTRACTOR shall use Reasonable Business Efforts to broadcast public education messages while Customers are waiting on hold to talk to a customer service representative.

4. Telephone Tree

CONTRACTOR shall require no more than two recorded options on a telephone tree before the caller speaks to a live customer service representative (for example, English/Spanish and residential/commercial service choices).

5. Answer Speed

CONTRACTOR shall use Reasonable Business Efforts to answer the telephone within four rings. CONTRACTOR shall answer 90 percent of all calls within the first 4 rings.

CONTRACTOR shall not leave the Customer on hold for more than ten minutes.

If Director determines that CONTRACTOR does not meet these Service Standards, Director may require that CONTRACTOR install additional telephone lines, hire additional customer service representatives, and make other customer service improvements without increasing Service Fees. Their determination will be based on whether the CONTRACTOR answers calls:

- Within five rings, based on at least three calls within one week, or
- 10 calls within one month.

6. Bilingual

CONTRACTOR shall respond to Customers and Occupants in English or Spanish as requested by the Customer or Occupant. Director may also require reasonable access to other languages such as through a translation service.

7. Knowledgeable Staff

CONTRACTOR shall provide customer service representatives with a knowledge of basic services in the CONTRACT. A supervisor with extensive CONTRACT knowledge is to be available to respond to questions or concerns by callers.

A representative answering a regional or nation-wide hotline with no CONTRACT specific training is not acceptable. Also, calling someone back after researching the correct answer is acceptable but providing the wrong information due to a lack of adequate training is not acceptable.

C. Paperless/Electronic Information and Services

1. Website

CONTRACTOR shall develop and maintain a website that includes the following information and Service options:

a. Service Information

Information such as Terms and Conditions form or service information, service brochures, newsletters, FAQ's, Holiday schedules, Christmas tree pick-up information, service changes, invoice explanations, allowable and forbidden discards, list of Recyclable and Organic materials, educational and outreach materials, notifications, alerts, and other information requested by Director.

b. *Bill Payment*

The ability for Customers to review and pay their bills online for all Collection Services including Extra Services Fees as referenced under item B3 of Section 7.

c. *Service Requests*

Requests for service Collection that is not regularly scheduled, including on-call Bulky Item Collections, requests for extra pickups, and service cancellations.

d. *Contact Us*

CONTRACTOR's contact information where Customers can register complaints and follow-up on complaint resolution.

e. *Link*

COUNTY may direct CONTRACTOR to add a link to Director's websites, such as but not limited to CleanLA.com, Smartbusiness.com and FoodDROPLA.com.

2. Paperless/Electronic Notifications

To reduce paper waste and reach more readers, CONTRACTOR shall offer their Customers the option to receive information via electronic notification. Information to be included in the electronic notification may include:

- Receiving service information described in preceding item C1a electronically, subsequently switching back to paper;
- Electronic billing under preceding item C1b;
- Making service requests under preceding item C1c; and
- Contacting CONTRACTOR under preceding item C1d.

CONTRACTOR shall give all educational messages and the template for service messages to Director for approval prior to sending to Customers. Upon Director's request, CONTRACTOR shall send messages provided by Director.

3. E-mail Address

CONTRACTOR shall maintain an e-mail address for use by Customers and Occupants and provide to Director upon request.

D. Responses to Customer Complaints and Other Correspondence

1. Resolution of Complaints

CONTRACTOR shall investigate all Customer and Occupant complaints including but not limited to service complaints such as missed pick-ups, customer billing and complaints related to non-compliance of SB 1383 requirements.

b. Call/E-mail for Service

CONTRACTOR shall maintain an e-mail address under preceding subsection C3 and telephone service under subsection B of this Section.

A call or e-mail from a Customer or Occupant to request a service or report an issue, such as a damaged container, is not considered a complaint.

c. First Complaint

CONTRACTOR shall address all Customer and Occupant complaints immediately and resolve them by the end of the next Service Day following Customer or Occupant contact or any reasonable time agreed upon between Customer or Occupant and CONTRACTOR. A Customer or Occupant should not have to call or e-mail to complain on the same issue because CONTRACTOR did not resolve it as previously committed by CONTRACTOR, such as a damaged Container was not repaired or replaced as committed.

d. Second and Subsequent Complaints

A Customer or Occupant should never have to call or e-mail to complain a second time on the same issue because CONTRACTOR did not resolve it as previously committed by CONTRACTOR.

e. Investigation of SB 1383 Regulatory Non-Compliance Complaints

The CONTRACTOR shall investigate any SB 1383 Regulatory Non-Compliance Complaints within their Service Area in efforts to assist the COUNTY in meeting the 90-day compliance deadline as stipulated in SB 1383 Regulations (14 CCR Section 18995.3(c)).

Upon CONTRACTOR completion of the investigation, the CONTRACTOR shall submit an investigation report that documents the investigation performed and shall recommend to the COUNTY on whether or not the entity investigated is in violation of SB 1383 based on the CONTRACTOR's investigation. The COUNTY shall make a final determination of the allegations against the entity.

2. Communications Log

CONTRACTOR shall enter, log, and maintain Records of all communications and their resolution, in computerized format and in compliance with County Code Section 20.72.160. CONTRACTOR shall maintain that log. CONTRACTOR shall submit the log for the applicable quarter to Director with CONTRACTOR's Quarterly Report under item A1 of Section 10.

3. County's Reimbursement Costs

If COUNTY employees or their contractors spend more than either of the following times resolving Customer complaints, then CONTRACTOR shall reimburse COUNTY its Reimbursement Costs that COUNTY incurred to resolve the complaint:

- Two hours in the aggregate resolving complaints from any single Customer that the Customer states have previously been filed with CONTRACTOR, or
- More than one hour in any work week (Monday through Friday) resolving complaints from different Customers.

The invoice for Reimbursement Costs should include all the following information:

- The address of the Premises being serviced,
- Customer who complained,
- Nature of complaint,
- Amount of time spent,
- Costs, including hourly fees for employees, agents or contractors who addressed the complaints, and
- Expenses, including phone and postage costs.

E. Service Interruption

CONTRACTOR shall monitor the Public Works Road Closure website (<http://pw.lacounty.gov/roadclosures/>) for conditions that may cause service interruptions. CONTRACTOR shall not alter or interrupt its service schedule without Director approval.

CONTRACTOR shall alert all Customers and Occupants of any Director-approved interruption in service and when service will resume. CONTRACTOR may use any type of communication, including phone blast, e-mail blast, and text messaging. Examples of interruption include various reasons, such as road closures, extreme weather conditions, or breakdown of CONTRACTOR equipment.

F. Responsiveness to Customer

Respond to communications such as telephone messages, text messages, and e-mails to the source that made contact no later than the next business day. If CONTRACTOR is unable to directly address the issue, CONTRACTOR shall respond with an acknowledgement to confirm receipt of message and indicate when the issue will be addressed.

Respond to United States Postal Service, Federal Express, or other courier provided correspondence from Customers or Occupants within one week of receipt.

G. Setting Up or Terminating Service

1. New Customers

- Obtain contact and service location information
- Explain services and charges
- Provide Customer Subscription Order form, Bill of Rights, most recent Bi-annual newsletter
- Mail brochure
- Offer Bulky Item Collection upon move-in/out
- Offer paperless/electronic notifications
- Deliver Containers
- Explain Organic Waste Diversion requirements and offer on-site training

2. Terminating Service

CONTRACTOR shall give each Customer the option to terminate its terms and conditions without cause on 14-days' Notice. CONTRACTOR shall refund any advanced payment for service after termination. CONTRACTOR shall notify COUNTY immediately upon Customer request to terminate.

Additionally, upon Customer request to terminate Collection Services the CONTRACTOR must complete the following:

- Offer Bulky Item Collection
- Explain what to do with Containers
- Explain refund procedure for any prepaid services

H. No Evergreen

CONTRACTOR shall not include in the terms of Customer Subscription Orders or other service contract with its Customers any automatic renewals or extensions, colloquially referred to as "evergreen" clauses, which obligate a Customer to take affirmative, prescribed action in order to terminate the Customer Subscription Order (such as giving written notice within a specified time period before the stated expiration of the Customer Subscription Order).

I. Term Limitation

CONTRACTOR shall limit the terms of Customer Subscription Orders to no longer than the remaining term of this CONTRACT.

J. No Charges

CONTRACTOR shall not impose a charge on a Customer that terminates Collection Services with or without cause, including Liquidated Damages, penalties, or removal fees for any Carts, Dumpsters or Roll-off Containers.

SECTION 7 - SERVICE RATES AND BILLING

A. Customer Service Rates

The CONTRACTOR shall bill all Customers at rates not to exceed those specified In Attachment 7-2, of Exhibit 7 Service Rates. The CONTRACTOR shall be solely responsible for providing accurate billing statements and collecting billing payments from Customers. Billing shall be performed on the basis of services rendered, including the minimum base rate (includes Refuse, Recyclables, and Organic Waste) and Extra Services Fees, as applicable. COUNTY is not liable for paying any Customer's invoices, including delinquencies and surcharges relating to contamination.

CONTRACTOR shall charge Customers accordingly as stipulated in Attachment 7-2 Service Rates of Exhibit 7, meaning Commercial Business, Multifamily, and Residential Customers will each have distinct Service Rates.

1. Uniform Rates

CONTRACTOR shall charge Customers the same, uniform Customer Service Rates for the same Collection Services listed in Attachment 7-2, Service Rates of Exhibit 7. For example, one Customer should not be charged \$10 for Scout Service while another Customer is charged \$8.

2. Base Rate

The Minimum Default Collection Service includes a minimum base rate for the Collection of Refuse which is agreed upon by the Customer and includes an automatic subscription of a 96-gallon Cart for Recyclables and a 64-gallon cart for Organic Waste at no additional charge, Collected once per week. Additional service days and additional size Containers beyond the minimum base rate shall be charged according to the Service Rates Schedule listed in Attachment 7-2 of Exhibit 7.

3. Extra Services Fees

The CONTRACTOR shall charge Customers accordingly for additional services as listed in Exhibit 7, Extra Services Fees to Customers. Maximum rates shall not go beyond what is specified. Some additional services include scout service, container locks, contamination fees, and additional Bulky Item pickups. See full list in Exhibit 7, Attachment 7-2, Extra Services Fees.

4. Roll-offs and Compactors

Refuse, Recyclables and Organic Waste Collected in Roll-off Containers and compactors shall be billed to the Customer at the rates specified in Attachment 7-2 of Exhibit 7, Service Rates Schedule. Rates included are specified for temporary and permanent Roll-offs and compactors.

CONTRACTOR may provide Roll-off Containers for Construction and Demolition Debris. CONTRACTOR shall charge the Customer as indicated in Attachment 7-2 of Exhibit 7, Extra Services Fees.

5. Rates for Customers with Waivers and Exemption

CONTRACTOR shall charge the Customers with the discounted rates as set forth in Attachment 7-2 of Exhibit 7, for any Customers that have been granted any waivers and/or exemptions by the COUNTY as referenced in item B of Section 1.

CONTRACTOR shall ensure that accurate Records are maintained for such waivers and exemptions and Customers are billed properly.

6. Senior Discount

CONTRACTOR shall discount the Customer's Basic Service Rate by 25 percent applied to Elderly Customers at Residential Premises such as:

(a) Residential Customers who have Dumpster Collection Services for Refuse and meet the following requirements:

(1) 62 or Older

The Customer is age 62 or older as evidenced by a driver's license or other document issued by a governmental entity.

(2) Head of Household

The Customer is a head of household as evidenced by his or her name on utility or telephone bills for the involved premises.

(3) Life-Line or Low Refuse Generator

The Customer either: (a) qualifies for discounted utility rates based on financial need (such as those referred to as "life-line" rates) as evidenced by water, power, or telephone bill for the involved premises, or (b) generates small amounts of waste and for Refuse uses only one 32-gallon Cart.

7. Rate Adjustments

Initial Service Rates are set based on the maximum rates proposed in the Exhibit 7 of Attachment 7-2, Service Rates Schedule. The Service Rates will thereafter be adjusted using the Consumer Price Index (CPI) for Trash and Garbage Collection (CUUR0000SEHG02), as described in Exhibit 7, Rate Adjustments. The first Rate Adjustment will be effective July 1, 2023.

B. Customer Invoice and Payment

1. Invoice Content

CONTRACTOR shall include in its Customer invoice the following information:

a. Contact Information

CONTRACTOR's telephone number, Office address, website and e-mail address for Customer complaints and questions.

b. Itemized Costs

Itemize costs in accordance with services. CONTRACTOR shall not identify that portion of a Customer's invoice attributable to a Franchise Fee, if any.

c. Paperless Option

A message promoting its website-based invoicing and payment system on all paper invoices sent to Customers.

At Director's request, CONTRACTOR shall promptly submit a copy of a Customer's invoice to Director.

2. Frequency

CONTRACTOR shall invoice all Customers monthly, or an alternate frequency as approved by Director. Additionally, CONTRACTOR shall invoice single-pass Customers quarterly as set forth in item M of Section 4, Single-Pass Collection.

Collection Services including any surcharges are to be billed to all Customers one month in advance. Bills shall be sent on or before the first day of the billing period. Payment in full is due no later than the last day of the month.

If Customer fails to pay bill, see item B7 of this Section for actions to be taken.

3. Electronic Invoicing

To reduce paper waste, CONTRACTOR shall make available and encourage to all Customers an electronic invoicing system at no additional charge. CONTRACTOR shall ensure that the electronic invoicing and payment website conforms to industry-standard practices for electronic commerce security. CONTRACTOR must ensure that these Customers receive invoice inserts such as newsletters either electronically or paper copies, as requested by Customer. Through CONTRACTOR's website, Customers may request to cease paper invoices and receive all invoices through e-mail or access them on CONTRACTOR's website.

4. Inserts

At Director's request, CONTRACTOR shall include a message and/or enclose with Customer's invoice all inserts prepared and provided by Director.

5. Electronic Payment

CONTRACTOR shall make available and encourage to all Customers an electronic payment system at no additional charge. This system will be website based and allow Customers to pay invoices through CONTRACTOR's website, both one-time and reoccurring. CONTRACTOR must allow credit card payments and may include direct bank routing or other payment methods.

6. Refunds

CONTRACTOR shall refund any overcharges to a Customer (including advance payments for Collection Services that are subsequently canceled) within 30 days after collection thereof. CONTRACTOR shall pay the Customer interest on overcharges (other than advance payments for subsequently canceled services) with interest thereon at ten percent per annum from the date originally overcharged until the date refunded.

7. Late Payment

Customer payment of bills are due to CONTRACTOR no later than the last day of the billed month. The following are the required warning notices and maximum allowable penalties for late payment. CONTRACTOR may be more lenient.

If payment is not received after 1.5 months, a reminder shall be sent to Customer indicating missed payment, balance due, and warning of ten percent late fee. If payment is not received by the last day of the second month, the account will become delinquent, and an additional ten percent fee may be added to the balance. If payment is not received after 2.5 months, a second reminder shall be sent to Customer indicating missed payment, balance due including ten percent late fee, and warning of stopping service

and Container removal. CONTRACTOR must provide Non-Collection Notice to Occupants as indicated in item A5 subsection a8, of Exhibit 3A1. If payment is not received after 3 months, Collection Service may be stopped. If payment is not received after 3.5 months, Collection Services may be interrupted by removing the Containers from the Premises and a \$25 interruption fee may be charged upon returning Containers to Premises. CONTRACTOR is to abide by any trespassing laws while removing Containers.

If Customer fails only to pay for surcharges for any or all special services in item A3 of Section 7, those special services shall be stopped without affecting other services. For example, if a Customer has an extra Refuse Container but is not paying the fee for the Container, the extra Container should not be Collected but all other Collection Services shall be provided.

A \$25.00 fee on returned checks (insufficient funds) may be charged to Customer.

Plain Language Table

| Elapsed Time | Action |
|-----------------------------------|---|
| Before or on 1st day of the month | Bill sent to Customer |
| 1 month | Bill due to CONTRACTOR |
| 1.5 months | Reminder sent with warning of late fee |
| 2 months | Unpaid bill delinquent, 10 percent late fee added |
| 2.5 months | Reminder sent with warning of stop service, container removal, and interruption fee |
| 3 months | Service stopped |
| 3.5 months | Containers removed, \$25 interruption fee |

The COUNTY may direct the CONTRACTOR to continue to provide Collection Services to delinquent Customers during health and safety emergencies (such as an earthquake, storm, or riot, pandemic or when Solid Waste is accumulating at Set-Out Sites for more than a week) as referenced in item B of Section 11.

SECTION 8 - WASTE CHARACTERIZATION STUDY

A. Participate with County Study

CONTRACTOR shall cooperate with Director in conducting Solid Waste characterization studies and waste stream audits. Cooperation includes all the following:

- Diverting Collection Vehicles from their regular route to alternate locations;
- Emptying all Solid Waste from Collection Vehicles; and
- Providing Collection, transportation, and Disposal of Solid Waste remaining after the study or audit.
- Providing copies of route maps

SECTION 9 - RECORDS

CONTRACTOR's obligations and COUNTY's rights in this Section survive the term.

A. Record Maintenance and Retention

1. All Records

CONTRACTOR shall prepare and maintain all Records in accordance with generally accepted accounting principles during the Term and for an additional period of not less than five years after the Expiration Date or any longer period required by Applicable Law.

a. *Legal Requirements*

CONTRACTOR shall maintain all records required under Applicable Law, including:

(1) records pertaining to Solid Waste Collection, and Disposal under County Code Section 20.72.160.

b. *Inter-jurisdictional Routes*

(1) *Acknowledgement*

CONTRACTOR acknowledges that if CONTRACTOR erroneously attributes Solid Waste that CONTRACTOR Collects in incorporated cities, other counties or Garbage Disposal Districts with Solid Waste that CONTRACTOR Collects in the unincorporated areas of the COUNTY under this CONTRACT, then the COUNTY may be subject to fines for failure to Divert Solid Waste from landfill Disposal as required under AB 939.

(2) *Obligation*

CONTRACTOR shall comply with 14 CCR 18808.7 and maintain records used to prepare Reports submitted to COUNTY, including jurisdiction of origin necessary to determine the weight of Solid Waste that CONTRACTOR Collects in the Service Area. CONTRACTOR shall document the method by which it allocates Solid Waste Collection route that includes a jurisdiction other than the COUNTY.

2. Disposal Records

CONTRACTOR acknowledges:

a. Claims

That COUNTY may need to respond to claims under CERCLA or similar Applicable Laws with respect to Disposal of Solid Waste.

b. Quantity

COUNTY's need to determine the quantity, location, and date of CONTRACTOR's Disposal of Solid Waste.

Therefore, CONTRACTOR shall establish and maintain a protocol for the retention and preservation of those Records, for a period of five years after the Expiration Date or any longer period required by Applicable Law, which protocol will document where CONTRACTOR Disposed of Solid Waste that it Collected (whether landfilled, incinerated, composted, or otherwise processed or marketed).

3. Notification

CONTRACTOR shall give Notice to Director at least 30 days before destroying Records of Disposal at any time after the retention period referred to in item A1 of Section 9.

B. County Custody

If Director has reason to believe that Records may be lost, discarded, or destroyed for any reason, Director may require that CONTRACTOR give COUNTY custody of any or all Records. Access to those Records will be granted to any Person duly authorized by CONTRACTOR. CONTRACTOR shall pay for storage cost.

C. Inspection and Review of Records

Upon five Service Days' notice by telephone or writing, or a lesser amount of time in the event of extraordinary circumstances, Director and/or its contractor may inspect, review (including using outside contractor), excerpt, transcribe, and copy all Records at CONTRACTOR's Office during CONTRACTOR Office Hours. CONTRACTOR may maintain Records outside of COUNTY (1) if it promptly provides copies thereof to Director at Director's offices, (2) if Director, in its sole discretion, agrees to travel outside COUNTY and CONTRACTOR pays COUNTY's Reimbursement Costs.

In addition to travel costs, COUNTY will bear the expense of the review and of obtaining a copy of Records; however, within 30 days of Director Notice, CONTRACTOR shall reimburse COUNTY for COUNTY's Reimbursement Cost of

the expenses for the review if the review reveals a discrepancy of the lesser of 3 percent or \$2,500 between:

- The amount contained in the Records (e.g., the amount of Solid Waste Collected or Diverted), and
- Any representation or Report that CONTRACTOR made to COUNTY; Franchise Fee or other money paid to COUNTY; County Service Fees paid by COUNTY, or information that CONTRACTOR submitted to Director.

Director may give Notice to CONTRACTOR identifying any discrepancy.

CONTRACTOR shall pay any discrepant shortfall in Franchise Fee or other payments due COUNTY, or excess of County Service Fees, upon Director demand, including fees and charges for the late payment of Franchise Fees. Failure to make those payments will constitute a CONTRACTOR Default in accordance with Part 3 of Exhibit 5. In lieu of payment, Director in its sole discretion may (1) deduct that shortfall from amounts that COUNTY owes CONTRACTOR under this CONTRACT, other contracts, or any other obligation, or (2) draw that shortfall from the performance bond, letter of credit, certificate of deposit, or other form of performance assurance provided by CONTRACTOR in accordance with Section 15.

COUNTY will pay any discrepant shortfall in County Service Fees due CONTRACTOR up to COUNTY's maximum obligation for County Service Fees appropriated by COUNTY for purpose of this CONTRACT.

D. Copies of Audits

If anyone, including Federal or State auditors and auditors or accountants employed by CONTRACTOR or others, conducts an audit of CONTRACTOR specifically regarding this CONTRACT, then within 30 days of the audit report, CONTRACTOR shall file a copy of the audit report with County's Auditor-Controller and notify Director of the filing, unless otherwise provided by Applicable Law. Subject to Applicable Law, COUNTY shall make a reasonable effort to maintain the confidentiality of such audit report(s).

E. Submission of Records

CONTRACTOR shall submit to Director, without charge to COUNTY or charge to Customers, any Records relating to Diversion requested by Director to assist COUNTY in meeting obligations imposed by Federal, State, and local laws. CONTRACTOR shall submit those Records by using the data management system forms used for submitting Reports or as requested by Director.

F. Public Record Request

1. Exclusive Property

The following become the exclusive property of COUNTY:

- Any Record or other document that CONTRACTOR gives Director, including about the procurement of this CONTRACT (such as proposals);
- Any Record or other document that Director obtains about Director's audit or inspection under this CONTRACT, including books and accounting records.

The above Records or other documents become a matter of public record and shall be regarded as public records, *except* if CONTRACTOR marks them as a "trade secret," "confidential," or "proprietary," they will be deemed excluded from disclosure under Government Code 6250 et seq. (Public Records Act). However, if a requestor seeking records marked "trade secret," "confidential," or "proprietary" does not agree that the records are exempt, then COUNTY will notify the CONTRACTOR that such records will be produced, unless the CONTRACTOR intercedes and files an injunction or other action to legally prevent disclosure.

CONTRACTOR agrees that COUNTY shall not in any way be liable or responsible for the disclosure of any such records including, with limitation, those so marked, if law requires disclosure, or by an order issued by a court of competent jurisdiction.

2. Defend, Indemnify and Hold COUNTY Harmless

CONTRACTOR shall defend, indemnify and hold harmless County from all costs and expenses, including reasonable attorney's fees, in connection with any requested action or liability arising under the Public Records Act, including request for any of the Records or other documents marked "trade secret," "confidential," or "proprietary." CONTRACTOR releases COUNTY from liability or responsibility for disclosing Records or other documents including those so marked, if Applicable Law require disclosure, including an order issued by a court of competent jurisdiction.

SECTION 10 - REPORTS

A. Types and Content

1. Quarterly Reports

The Director may request any Reports or data be reported prior to the Quarterly Reports submissions as referenced under subsection D of this Section.

Within 30 days after the end of each calendar quarter, or as determined by Director, CONTRACTOR shall submit the Quarterly Report for the preceding three (3) calendar months ending with that month to Director using the forms maintained on the data management system or provided by Director, which includes the following information:

a. Tonnage Report

CONTRACTOR shall report the total quantities in Tons of Materials Collected, Transferred, Processed, and Disposed by the CONTRACTOR. The report shall contain Tonnage data broken down by Container type Collected and must identify each Processing facility(ies) utilized for each Container type Collected.

b. Rejected Recyclables and Organic Waste

CONTRACTOR shall report the number of loads and Tons of Recyclables and Organic Waste rejected for Processing based on the Collection Container, together with the reason for rejection and facility at which the rejected materials were Disposed.

c. Educational Materials

CONTRACTOR shall report all educational materials distributed, and any events attended by CONTRACTOR to its Customers. Reports shall include dates when materials were distributed, along with the Service Area(s) it was distributed, location of events held, and which Customer type received the education material (i.e., Residential, Multifamily, Commercial, or all Customers).

d. Non-Collection Notices

CONTRACTOR shall report the total number of Non-Collection Notices issued, date/time of non-collection incidents, and the reasons for issuance including the list of Customers along with the Customer/Occupant information such as addresses, and service

levels. CONTRACTOR shall also provide dated photographic evidence of Non-Collection Notices issued and photographs of Customer non-collection incidents.

e. *Customer List*

CONTRACTOR shall report and provide a Customer list which includes all active and inactive accounts, account numbers, name associated with each account, Customer phone number, address and e-mail address, service site location address, level of service and material type Collected for each Container provided at each address, service day(s), additional services provided, indicate exemption or waiver type if applicable, and any other information associated with the Scope of Services as requested by Director.

Along with COUNTY's Customer list, the CONTRACTOR must provide their incorporated Customer list which should only include the Customer's service location addresses.

CONTRACTOR shall also indicate which Customers are not subscribed or adequately subscribed to Solid Waste Collection Services.

Additionally, CONTRACTOR shall report on Customers mentioned in subsection B of Section 1.

f. *Financial Report*

CONTRACTOR shall provide financial report(s) for all serviced Customers. Financial reports may also include a monthly billing and gross receipts report. The report(s) shall include and are not limited to, account number, account name, account address, service location/site address, invoice number, invoice date, billing amount/current charges in detail by billing description (i.e. 4YD FL Refuse, 3YD FL Recycle, late charge, etc.), payment received, payment date, payment type (i.e. check/cash/money order), account balance to date, and any other information as requested by Director.

g. *Customer Service Communications Log*

CONTRACTOR shall provide a copy of the customer service log which should include all service complaint activities and SB 1383 Regulatory Non-Compliance Complaints.

(1) *Service Complaints*

Logs shall include the Customer's information such as Occupant and/or Customer's phone number and/or e-mail

address, address, a summary of the type and number of complaints, missed pickups, and Non-Collection Notices and their resolution in a format acceptable by COUNTY.

(2) SB 1383 Regulatory Non-Compliance Complaints

CONTRACTOR shall report the number of complaints that were received and investigated, and if applicable, any educational materials issued to the Customer and resolution as referenced in item D1d of Section 6.

h. Containers Removed Upon Director Request

(1) Carts or Dumpsters Stored in Right-of-Way

CONTRACTOR shall report the number and addresses of Containers removed, fees charged, and Containers returned, per item C7d of Exhibit 3A1.

i. Contamination Monitoring

CONTRACTOR shall report the number of route reviews conducted for contamination monitoring and the number of times notices, violations, or targeted education materials were issued to Customers for Container Contaminants including the total number of Containers Disposed as Refuse due to the observation of Container Contaminants as described in item J1 of Exhibit 3A1.

j. Facility List

CONTRACTOR shall report and identify all Solid Waste Facilities used to Process all materials Collected. If utilizing a High Diversion Organic Waste Processing facility to Process Mixed Waste Collection, CONTRACTOR shall identify such facility and must include the Recycling and Disposal Reporting System (RDRS) identification number for the facility(s).

CONTRACTOR shall also report the facility tip fee and Diversion rates per Processed material group (e.g., Recyclables, Organic Waste, Food Waste and Mixed Waste).

k. Customer Waivers

CONTRACTOR shall maintain a record of waiver requests and COUNTY issued De Minimis and Physical Space waivers. CONTRACTOR records must reflect COUNTY Records and any changes to a Customer's eligibility shall be reported to the COUNTY immediately. CONTRACTOR shall also notify the COUNTY of

generators CONTRACTOR believes is eligible for a De Minimis and/or Physical Space waiver.

l. Site Visits

CONTRACTOR shall provide the Director a detailed summary Report of the site visits that were conducted and it shall include the following: No. of site visits performed during the quarter, the name and address of each Customer visited including the contact name and phone number, the date of each visit, any recommendations for service level changes, any outreach provided and summary of site visit and outcome.

m. Commercial Edible Food Generators

CONTRACTOR must report to COUNTY if they notice Edible Food in any Solid Waste Container and indicate the estimated percentage and/or pounds of Edible Food Disposed.

In addition, the Report shall include the Commercial Edible Food Generator's business name if applicable, the corresponding account holder name(s), account number, contact information, address, and photographic evidence of the Disposed Edible Food.

n. Bulky Item Collections

CONTRACTOR shall report all Customers that received Bulky Item Collection Services, number of pick-ups and number of items in each pick-up.

o. Contamination and Other Fees

CONTRACTOR shall provide to Director a list of Customers who were charged a contamination fee, Container violation fee or an extra pick-up fee as referenced In Exhibit 7, Attachment 7-2 (Extra Services Fees).

p. Collection Route Maps

CONTRACTOR shall e-mail changes in Collection route maps and schedule during the prior month.

q. Special Events Collection

CONTRACTOR must notify and report to COUNTY the Collection Services that CONTRACTOR provided at any special events located within the unincorporated communities of Los Angeles County.

The Report shall include the type of Collection Service provided (e.g., Refuse, Recycling and/or Organic Waste Collection) and service level, name and address of event, event coordinator contact information, and any other information associated with the event that may be requested by the Director.

Additionally, CONTRACTOR must notify COUNTY immediately if the special event includes any Edible Food activity.

2. Annual Report

On or before each February 28, CONTRACTOR shall submit the Annual Report to Director in a form satisfactory to Director, for the preceding Calendar Year, including the following information:

a. Solid Waste Diversion Program Implementation

A Report of CONTRACTOR's compliance with its Performance Obligations with respect to Solid Waste Diversion program implementation during the preceding Calendar Year. This Report includes, but is not limited to, CONTRACTOR explanation of their Solid Waste Diversion efforts.

b. Subcontractors

An updated list naming all Subcontractors, the amount of Goods or Services that each Subcontractor provides to CONTRACTOR, and a description of CONTRACTOR's relationships to each Subcontractor (including ownership interests) in accordance with Part 5K of Exhibit 5.

c. Collection Vehicle Compliance

Each Vehicle's compliance with any applicable local, state and federal regulations and requirements including South Coast Air Quality Management District Rule 1193, Clean On-Road Residential and Commercial Collection Vehicles, and Diesel Particulate Matter Control Measures (13 California Code of Regulations 202 et seq.).

d. Scavenging

A narrative description of efforts made to deter and prevent unauthorized removal or scavenging of Recyclables.

e. Vehicles

An inventory of Vehicles assigned to the Service Area and information on each Vehicle including its number, fuel type, year,

make, model, license plate number, VIN number, assigned route with start and finish points, days of service, type of material Collected, and number of accounts being serviced. CONTRACTOR shall update and submit immediately if any Vehicle, route or information has changed during the prior year.

f. Procurement of Recovered Organic Waste Products

(1) RNG Procurement

CONTRACTOR shall report the total amount of renewable natural gas (RNG) procured by CONTRACTOR for use in automated Collection Vehicles dedicated for CONTRACTOR's Service Area, pursuant to Section 3C, in diesel gallon equivalents (DGE). The CONTRACTOR shall include copies of any receipts, invoices, or other similar documentation evidencing procurement.

(2) Alternative Procurement Plan (If Applicable per item J4 of Exhibit 3A1)

CONTRACTOR shall include copies of any receipts, invoices, or other similar documentation evidencing procurement activities.

g. Processing Facility Reports

(1) Plastic or Compostable Bags

If CONTRACTOR Collects Organic Waste in plastic or Compostable bags, CONTRACTOR must provide a written representation and warranty from the Processing facility to the Director that the approved Organic Waste Processing Facility has and will continue to have the capabilities to Process and remove plastic or compostable bags when it recovers Source Separated Organic Waste.

(2) High Diversion Organic Processing Facility

CONTRACTOR shall provide copies of quarterly and annual average Mixed Waste Organic content recovery rates for each High Diversion Organic Waste Processing Facility used by CONTRACTOR to demonstrate that the facility(ies) meets or exceeds the Organic Waste content recovery requirements specified in 14 CCR Section 18984.3.

(3) *Compostable Plastics*

If CONTRACTOR accepts Compostable Plastics, CONTRACTOR must provide a Written notification to the Director that the approved Organic Waste Processing Facility(ies) has and will continue to have the capabilities to Process and recover the Compostable Plastics included with the Source Separated Organic Waste transported to the approved Organic Waste Processing Facility.

(4) *Quarantined Organic Waste*

CONTRACTOR shall provide a record of all compliance agreements for quarantined Organic Waste that are Disposed of, including the name of Generator, date issued, location of final disposition, and the amount of quarantined Organic Waste that was required to be Disposed at a Landfill.

(5) *Temporary Equipment or Operations Failure*

If CONTRACTOR is granted a Processing facility temporary equipment or operational failure waiver in accordance with item D5 of Exhibit 3A1, CONTRACTOR shall report the following documents and information:

- a. The number of days the Processing facility temporary equipment waiver or operation failure waiver was in effect;
- b. Copies of any notifications sent to the Director pursuant to item D5 of Exhibit 3A1, and copies of COUNTY notices to CONTRACTOR pursuant to item D5 of Exhibit 3A1;
- c. Documentation setting forth the date of issuance of the waiver, the timeframe for the waiver; and,
- d. A record of the Tons of Recyclables, Organic Waste, and Mixed Waste materials redirected to an alternative Solid Waste Facility or Disposed at an approved Solid Waste Disposal Facility as a result of the waiver, recorded by Collection Vehicle or transfer vehicle number/load, date, and weight.

3. Reports of Unauthorized Collectors

As described in item B10 of Section 1, if CONTRACTOR discovers that any Person is providing MSW Management Services in the Service Area who is

not authorized by Director or is in Violation of Applicable Law, then CONTRACTOR shall promptly e-mail Director with the following:

- The identity and address of the Person ("Violator"), if known;
- The facts and documentation supporting CONTRACTOR's report; and
- Any other information or documentation about the Violator and CONTRACTOR's report that Director may reasonably request.

COUNTY acknowledges that CONTRACTOR may seek legal or injunctive relief against the Violator in accordance with Applicable Law to cease providing those MSW Management Services. Notwithstanding the foregoing, COUNTY is not liable to CONTRACTOR, and CONTRACTOR hereby releases COUNTY from liability for any act of a Violator.

4. Legally Required Reports

CONTRACTOR shall file all Reports required under Law, including County Code Section 20.72.50 (Area, Services, Rates and Schedules).

5. Improper Solicitations

CONTRACTOR shall immediately report any attempt by a COUNTY officer or employee to solicit improper consideration (including in the form of cash; discounts; service; or the provision of travel, entertainment, or tangible gifts), to:

(1) COUNTY manager charged with the supervision of the employee;

or

(2) the COUNTY Fraud Hotline at (800) 554-6861 or www.fraud.lacounty.gov

B. Submission of Reports

CONTRACTOR shall submit Reports in a format compatible with COUNTY's computers and shall submit Reports using the following methods:

1. Quarterly Reports and Annual Report

Submitted via e-mail or other electronic form or printed copy, as determined by Director, in accordance with this Section and Section 12.

C. Reporting Adverse Information

CONTRACTOR shall provide Director copies of all Reports, pleadings, applications, notifications, and notices of violation, communications or other material directly relating to its Performance Obligations submitted by

CONTRACTOR to, or received by CONTRACTOR from Regulatory Agencies, including any of the following:

- The United States or California Environmental Protection Agency;
- CalRecycle;
- The Securities and Exchange Commission;
- Any other Regulatory Agency; and,
- Any Federal, State, or County court.

CONTRACTOR shall submit copies to Director simultaneously with CONTRACTOR's submission of those materials to those entities. At Director's request, CONTRACTOR shall promptly make available to Director any other correspondence between CONTRACTOR and those entities.

D. County's Right to Request Information

At Director's request, CONTRACTOR shall promptly provide to Director additional information reasonably and directly pertaining to this CONTRACT (including substantiation of information submitted in Reports).

E. Reports of Cybersecurity Breaches

CONTRACTOR must notify the Director immediately if CONTRACTOR's data security system encounters any cyber security breach.

SECTION 11 - SUBSTITUTE, EMERGENCY AND BACK-UP SERVICE

A. Director's Right to Provide Contract Services

1. Events

COUNTY may provide, or contract with a third party to provide, for the performance of, any or all Customers services in either of the following events, determined by Director in its sole discretion:

a. Unable for a Period of 48 Hours to Collect

- For 48 consecutive hours CONTRACTOR does not Collect and Dispose of any type of Solid Waste for any reason, including Uncontrollable Circumstances, or
- Director determines there is danger to public health, safety, or welfare.

b. COUNTY Suspends or Terminates CONTRACT

COUNTY suspends or terminates all or a portion of the CONTRACT.

COUNTY has no obligation to continue providing any or all Contract Services. It may stop providing them at any time, in its sole discretion. However, COUNTY may continue to provide those Contract Services until either of the following occurs:

- CONTRACTOR demonstrates to Director's satisfaction that CONTRACTOR is ready, willing, and able to resume providing timely and full Contract Services, or
- Director can make alternative arrangements for providing MSW Management Services comparable to Contract Services in scope and price. Alternative arrangements may include contracting with another, third-party service provider.

2. Notice

Director may give CONTRACTOR oral notice that Director is exercising its right to perform Collection Services, which notice is effective immediately, but must confirm oral notice with a Notice within 24 hours thereafter.

3. Stipulations

CONTRACTOR stipulates that COUNTY's exercise of rights under this Section does not constitute a taking of private property for which COUNTY must compensate CONTRACTOR, shall not create any liability on the part

of COUNTY to CONTRACTOR, and does not exempt CONTRACTOR from any Indemnities, which Parties acknowledge are intended to extend to circumstances arising under this Section. However, CONTRACTOR is not required to indemnify COUNTY against claims and damages arising from the negligence or misconduct of COUNTY officers and employees (other than employees of CONTRACTOR at the time COUNTY began performing Collection Services) and agents driving Vehicles. COUNTY shall indemnify CONTRACTOR, its Affiliates and its and their officers, directors, employees, and agents from and against damages, costs, or other expenses or losses they incur arising out of or relating to that negligence or misconduct.

4. Rental and Other Compensation

a. *Uncontrollable Circumstances*

If an event enumerated in items A1a or A1b in Section 11 is due to Uncontrollable Circumstances, then COUNTY shall pay CONTRACTOR the Direct Costs below.

(1) *Rental Fees*

Rental fees for the use of equipment equal to fair market value thereof as determined by an independent appraiser selected by the Parties.

(2) *Vehicles*

CONTRACTOR's Direct Costs of providing Vehicles with fuel, oil, and other maintenance.

(3) *Personnel*

CONTRACTOR's Direct Costs of making CONTRACTOR's personnel available to COUNTY, including Direct Costs of using CONTRACTOR's personnel to operate CONTRACTOR's equipment or vehicles.

The Parties shall select an appraiser as follows: within ten days after CONTRACTOR requests payment of rental fees in events described in item (1) of this subsection 4a, each Party will prepare a separate list of five Persons who do not work for either Party having experience in Solid Waste equipment appraisal, in numerical order with the first preference at the top, and exchange and compare lists. The Person ranking highest on the two lists by having the lowest total rank order position on the two lists is the appraiser. In case of a tie in scores, the Person having the smallest difference between the rankings of the two Parties is selected; a coin toss determines other ties. If no Person appears on both lists, this procedure is repeated.

If selection is not completed after the exchange of three lists or 60 days, whichever comes first, then each Party will select one Person having the qualifications and experience described above and those two Persons will together select an appraiser.

b. *Other Than Uncontrollable Circumstances*

If an event enumerated in items A1a or A1b in Section 11 is not due to Uncontrollable Circumstances, then COUNTY will not be obligated to pay the compensation and CONTRACTOR shall pay COUNTY's Reimbursement Costs within 10 days of COUNTY's submitting an invoice, therefore. If CONTRACTOR does not so timely pay, COUNTY may draw upon any performance bond, letter of credit, or other security provided under this CONTRACT.

B. Customer Services - Response to Emergencies

Depending on the extent and magnitude of an emergency, Customers may encounter issues with making payments and CONTRACTOR may be unable to fulfill all CONTRACT requirements. Upon declaration of a Federal, State or Local emergency, Director may implement the following policies with written Notice regarding Collection Services:

1. No Stop Service

CONTRACTOR shall not stop service to any account for delinquent payment during an emergency. Not applicable to debt prior to the emergency.

2. No Late Fees

CONTRACTOR shall not charge late fees on bills unpaid amount incurred during the emergency. Not applicable to debt prior to the emergency.

3. Extended Payment Option

CONTRACTOR shall allow Customers up to 12 months after an emergency to make monthly payments to debt incurred during the emergency. Not applicable to debt prior to the emergency.

4. Adjustment of Existing Services

COUNTY shall consider implementing changes such as:

- **Non-essential services suspend**
 - Cart exchanges if they are still usable
- **Bulky Item collection may be delayed up to 3 weeks** from call-in (not applicable to service areas where call-in is not required)

- **Collection hours are expanded to 6 am to 8 pm**
- **Time required to speaking to a live customer service representative** may be extended but Public Works must be notified if the average time exceeds 20 minutes.
- **Weekly collection modified**
 - Biweekly Organic Waste
 - Biweekly Recyclables (residents stockpile and compact their Containers to fit more)
 - Alternating weeks of Recyclables and Organic Waste
 - Comingled trash with Recyclables and/or Organic waste.

5. Adjustment of Franchise Fees

a. Debt Incurred During Emergency

12 months after an emergency, COUNTY will pay to the CONTRACTOR half the amount of any debt incurred as a result of Customers not paying their bills during an emergency. CONTRACTOR must submit documentation to the satisfaction of the Director demonstrating the amount of any such debt. Future Franchise Fees invoices will be adjusted by Director. For example, if the CONTRACTOR has \$100,000 of unpaid bills 12 months after an emergency, Director will reduce the Franchise Fee invoice by \$50,000. If CONTRACT will terminate prior to the 12 months, Director will consider an alternate timeline.

At any time after the Director has authorized the debt to be deducted from Franchise Fee and CONTRACTOR is able to recover additional payments from Customers, or former Customers, those recovered funds must be shared equally with COUNTY.

b. Franchise Fee Payment Extension

Director will consider adjusting Franchise Fees during an emergency, extending the deadline to pay an invoice.

C. Backup Service Plan

CONTRACTOR shall implement its Backup Service Plan within seven days of Director request if Customer's Solid Waste is not Collected at Customer's Set-Out Site, including uncontrollable circumstances. Examples of circumstances include CONTRACTOR's employees on strike or mudslides, wildfires, or earthquakes that cause blocked or damaged roads. In the event there is a protracted service disruption due to any cause, CONTRACTOR will institute proactive actions to sustain Solid Waste Collection Services. Since Customers are expecting services that CONTRACTOR is not providing, CONTRACTOR shall propose the appropriate services below for Director approval and must not charge Customer or COUNTY for providing these services, unless noted below.

1. Provide Conveniently Located Dumpsters or Roll-off Containers

CONTRACTOR will place 3 or 4-yard Dumpsters and/or Roll-off Containers throughout the community in key locations approved by Director.

2. Offer Self-hauling of Solid Waste to a Facility

CONTRACTOR will use Reasonable Business Efforts to make arrangements with the Solid Waste Disposal Facility normally used by CONTRACTOR for this Contract to allow each Occupant to direct haul and dispose of their Solid Waste, 6 days per week. The facility shall only charge the Customer for Disposal costs for quantities exceeding 100 pounds and there shall be no minimum quantities.

Additionally, if Director determines the distance to the CONTRACTOR's usual facility is too far from Occupants, CONTRACTOR will arrange for a local facility to allow each Occupant to drop-off the Solid Waste.

3. Inform Customers of Temporary Procedures

CONTRACTOR will use Reasonable Business Efforts to inform Customers and Occupants of the above service and Disposal options. CONTRACTOR will provide Customers and Occupants with information on where and how to dispose of the Occupant's Solid Waste by the following means:

- A recording on its customer service line.
- Arrange for the broadcast of COUNTY's 30-second Public Service Announcement video on local cable access channels with CONTRACTOR to customize it to the situation, such as having text appear on the screen announcing date, times, and addresses.
- Contact local print media and produce a press release.
- Contact Customers and Occupants via phone, e-mail, or text messages.

4. Credit Policy for Missed Contract Services

a. Missed Curbside Collection

Since Occupant is expecting a Collection Service not provided, CONTRACTOR shall automatically credit Customer for each missed Collection. For example, if a strike disrupts 2 weeks of the 13 Collections in a quarter, CONTRACTOR would credit Customer 2/13 of that quarter's fee toward the next quarter's fee.

b. Other Customer Services

When CONTRACTOR is unable to offer Collection Services other than curbside Collection, such as Bulky Item Collection, Community Meetings, or other required services, CONTRACTOR shall provide evidence of cost associated with those services and offer alternate services acceptable to Director.

5. Provide Replacement Drivers and Security

CONTRACTOR shall use Reasonable Business Efforts to require all properly trained and licensed employees to operate Collection Vehicles to maintain core Disposal and Diversion services. As described in the above paragraphs, CONTRACTOR shall be properly staffed to provide drop-off services for each Occupant. In addition to CONTRACTOR staff, CONTRACTOR shall use drivers or Vehicles from other operations and other waste haulers.

Finally, in cases of a strike, CONTRACTOR shall work closely with a private security firm to guarantee a safe and consistent operation.

6. Identify Customers Requiring Priority Service

CONTRACTOR shall contact the elderly and disabled Occupants and shall use Reasonable Business Efforts to Collect putrescible Solid Waste from their residence.

D. Use of Goods, Services and Property

1. Dumpsters and Cart Acquisition Contracts

CONTRACTOR acknowledges that COUNTY must have full use and possession of Dumpsters and Carts to secure its rights under this Contract, including both the following:

- Providing substitute service in accordance with its remedies under Part 3 of Exhibit 5 for Breach or default, and
- Purchasing Dumpsters and Carts upon termination of this Contract.

Therefore, if CONTRACTOR does not own Dumpsters and Carts outright without encumbrance, any Dumpster and Cart Acquisition Contract shall allow the Guarantor, COUNTY or COUNTY designee, to do all the following:

- Assume CONTRACTOR's obligations under the Dumpster and Cart Acquisition Contract,
- Take use and possession of the Dumpsters and Carts, and
- Obtain the benefits of any outstanding Cart warranties.

“Dumpsters and Cart Acquisition Contract” means an instrument establishing a security interest in the Dumpsters and Carts or that otherwise encumbers or limits CONTRACTOR's interest in Dumpsters and Carts, including any of the following:

- Lease or lease-purchase agreement,
- Installment sales or other financing contract, or
- Note or other loan documentation.

2. Inventory

CONTRACTOR shall store unused Dumpsters and Carts in a secure location. CONTRACTOR shall update its Dumpsters and Carts inventory at both following times:

- In each Monthly Report and Annual Report, and
- Within one week of COUNTY request

3. Insurance

If COUNTY or Customers have possession and use of Goods, Services and Property, CONTRACTOR shall execute whatever documentation its liability insurers require to ensure that COUNTY and Customers are protected and covered by CONTRACTOR's general and automobile policies, including requesting and executing endorsements to those policies. CONTRACTOR is not obligated to pay any additional cost of those endorsements unless COUNTY reimburses CONTRACTOR for those costs. COUNTY may pay for any endorsements, additional premiums or other costs. CONTRACTOR authorizes COUNTY to call and confer with CONTRACTOR's insurance broker to determine what, if any, documentation or actions are necessary to achieve protection satisfactory to COUNTY. Upon COUNTY REQUEST, CONTRACTOR shall direct its insurance broker to cooperate with COUNTY.

4. Vehicle Certification for FEMA

CONTRACTOR shall cooperate with COUNTY to certify all Vehicles to be used for emergency work. CONTRACTOR shall not use non-certified Vehicles unless approved by Director.

SECTION 12 - ENFORCEMENT OF CONTRACT

A. As Provided by Law

Either Party may avail itself of any remedy available under law.

B. COUNTY's Additional Remedies

Without limiting COUNTY's remedies otherwise available under this CONTRACT in law or equity, at its option, COUNTY may enforce a Breach in any or all the following ways:

- Execute alternative CONTRACTs for MSW Management Services in the event of CONTRACTOR Default
- Seek to obtain injunctive relief and/or damages
- Assess damages under item D of this Exhibit
- With respect to a CONTRACTOR Default under Part 3B3 of Exhibit 5 (Failure to Provide Insurance, Bonds), immediately withhold payments due CONTRACTOR
- Draw on Performance Assurance / Letter of Credit under Section 15

C. Injunctive Relief

CONTRACTOR acknowledges that COUNTY's remedy of damages for a Breach may be inadequate for reasons including the following:

- The urgency of timely, continuous, and high-quality Collection Services, including Collection, transportation, and/or transfer for Disposal of wastes which constitute a threat to public health;
- The long time and significant commitment of money and personnel and elected officials (both COUNTY staff and private consultants, including engineers, procurement counsel, citizens, public agency colleagues, and elected County officials) invested in this CONTRACT, including developing COUNTY's Option Analysis dated February 2001 and implementing its recommendations through numerous meetings of a Working Group comprised of Solid Waste industry representatives from small and large businesses, requesting and evaluating qualifications and proposals for this CONTRACT (including CONTRACTOR's), reviewing and commenting on documentation submitted by CONTRACTOR in conjunction with execution of this CONTRACT, and review of CONTRACTOR Documentation;
- The time and investment of personnel and elected officials described in the preceding paragraph to develop alternative Solid Waste services for the price provided under this CONTRACT, and to negotiate new contracts therefore; and

- COUNTY's reliance on CONTRACTOR's technical Solid Waste management expertise.

Consequently, COUNTY is entitled to all available equitable remedies, including injunctive relief.

D. Recovery of Damages

1. Compensatory

Subject to CONTRACTOR's opportunity to cure under Exhibit 5 Part 3, and mitigation of any damages by COUNTY, in the event that COUNTY seeks recovery of damages for a Breach, COUNTY may seek either compensatory damages or liquidated damages, as follows.

- Amounts equal to any Franchise Fees, liquidated damages, or other amounts that CONTRACTOR has previously paid to COUNTY but are subsequently recovered from COUNTY by a trustee in bankruptcy as preferential payments or otherwise;
- If COUNTY terminates this CONTRACT for a CONTRACTOR Default or in the event of Criminal Activity in accordance with Part 3D2c of Exhibit 5, costs incurred by COUNTY to provide or reprocur MSW Management Services in lieu of Collection Services;
- If COUNTY terminates this CONTRACT before expiration for a CONTRACTOR Default or in the event of Criminal Activity in accordance with Part 3D2c of Exhibit 5, costs of MSW Management Services provided or reprocured in lieu of Collection Services more than Customer Service Rates for the balance of the Term remaining if this CONTRACT had not been terminated; and
- In the event of CONTRACTOR Default under Part 3B3 of Exhibit 5 (Failure to Provide Insurance, Bond), in COUNTY's sole discretion, obtain damages resulting from that Default.

COUNTY may draw upon the performance bond, letter of credit, certificate of deposit, or other form of performance assurance provided by CONTRACTOR in accordance with Section 15 to pay compensatory damages.

For CONTRACTOR's misrepresentation regarding contingent fees in Attachment 5-8H, in addition to terminating this CONTRACT, COUNTY may recover from CONTRACTOR the full amount of the proscribed commission, percentage, brokerage, or contingent fee.

2. Liquidated Damages

COUNTY may seek liquidated damages listed in Attachment 12-D2.

The Parties have set these liquidated damages in recognition of the following circumstances existing at the time of the formation of this CONTRACT:

- a. COUNTY incurred considerable time and expense procuring this CONTRACT to secure an improved level of Collection quality and increased Customer and Occupant satisfaction. Therefore, consistent and reliable Collection Services are of the utmost importance to COUNTY and Customers and Occupants.
- b. COUNTY has considered and relied on CONTRACTOR's representations as to its quality-of-service commitment in entering into this CONTRACT, and CONTRACTOR'S Breach represents a loss of bargain to COUNTY. CONTRACTOR is experienced in providing services like those described in Collection Services.
- c. Quantified standards of performance are necessary and appropriate to ensure quality, consistent, and reliable Collection, and if CONTRACTOR fails to meet its Performance Obligations, COUNTY will suffer damages (including its Customers and Occupants' inconvenience; anxiety, frustration, potential political pressure, criticism, and complaint by Customers and Occupants; lost Supervisors and staff time; deprivation of the benefits of this CONTRACT and loss of bargain) in subjective ways and in varying degrees of intensity that are incapable of measurement in precise monetary terms, and that it is and will be impracticable and extremely difficult to ascertain and determine the value thereof. It would be difficult for COUNTY to prove its loss resulting from CONTRACTOR's Breaches and nonperformance or untimely, negligent, or inadequate performance of County Services.
- d. The CONTRACT contains a reasonable statement of Collection Services in order that the Parties will realize their expectations. COUNTY expects that CONTRACTOR shall perform Collection Services with due care in a workmanlike, competent, timely, and cost-efficient manner. CONTRACTOR expects to realize a profit by performing Collection Services in accordance with the terms and conditions of the CONTRACT for County Service Fees.
- e. In addition, in the event of Breach or CONTRACTOR Default, urgency of protecting public health and safety may necessitate that COUNTY enter into emergency or short-term arrangements for services without competitive procurement at prices substantially

greater than under this CONTRACT, and the monetary loss resulting there from is impossible to precisely quantify. Time is of the essence.

- f. The CONTRACTOR accepts COUNTY's assessment of liquidated damages for certain Breaches as part of the consideration CONTRACTOR offers to COUNTY for the award of this CONTRACT to CONTRACTOR.
- g. Lastly, termination of this CONTRACT for CONTRACTOR Default and other remedies provided in this CONTRACT are, at best, a means of future correction and not remedies that make COUNTY whole for past Breaches and CONTRACTOR Defaults.

Therefore, the Parties agree that the liquidated damages listed in Exhibit 12-D2 represent a reasonable estimate and fair approximation of the amount of damages COUNTY would incur as a consequence of CONTRACTOR's Breach corresponding to each item of specified liquidated damages, considering all the circumstances existing on the date of this CONTRACT, including the relationship of the sums to the range of harm to COUNTY that reasonably could be anticipated and anticipation that proof of actual damages would be costly or inconvenient.

In signing this CONTRACT, each Party specifically confirms the following:

- The accuracy of the statements made above, and
- The fact that each Party had many opportunities to consult with legal counsel and obtain an explanation of this liquidated damage provision at the time that this CONTRACT was made.

E. County's Reimbursement Costs

CONTRACTOR shall pay COUNTY promptly upon request, COUNTY's Reimbursement Costs of conducting a nonroutine investigation of any alleged Breach, when appropriate in judgment of Director. CONTRACTOR shall reimburse COUNTY for COUNTY's Reimbursement Costs incurred because of CONTRACTOR's Breach, including failure to maintain insurance.

F. Waiver

No waiver by COUNTY of any Breach of any provision of this CONTRACT constitutes a waiver of any other Breach of that provision. Failure of COUNTY to enforce at any time, or from time to time, any provision of this CONTRACT will not be construed as a waiver thereof. The rights and remedies set forth in this item F are exclusive and are in addition to any other rights and remedies provided by law or under this CONTRACT.

SECTION 13 - UNPERMITTED WASTE SCREENING AND REPORTING

A. Protocol

CONTRACTOR shall develop and implement the Unpermitted Waste Screening Protocol in compliance with Applicable Law and including the following provisions:

- Ongoing employee training in identification, safety and notification procedures, including leaving Non-Collection Notices, when safe;
- Means of driver inspection, such as visual inspection during tipping of Carts into Vehicles;
- Immediate driver response, such as load segregation;
- Driver notification, such as calling CONTRACTOR's dispatcher or field supervisor;
- Notification of appropriate local agency or department;
- Appropriate action, such as segregation and containerization for manifesting and transport for Disposal in accordance with Applicable Law or securing services of permitted handling and transport company;
- Compliance with Applicable Law, including regulations of the United States Department of Transportation (DOT) (Title 49 CFR) and of the United States Environmental Protection Agency (Title 40 CFR); and
- Labels on Containers, described in item D of this Section.

B. Prohibition on Collection

CONTRACTOR shall not Collect any Unpermitted Waste that it finds in Refuse, Recyclables, or Organic Waste unless it is licensed under Applicable Law. If CONTRACTOR finds Unpermitted Waste it shall notify all Persons as required by Applicable Law.

C. Notice to Director

If CONTRACTOR sees anything that it reasonably believes or suspects may be Unpermitted Waste on any public property in COUNTY, CONTRACTOR shall immediately notify Director and all Persons in compliance with Applicable Law. Public property includes storm drains, streets, and other public rights of way.

D. Labels

CONTRACTOR shall conspicuously label Containers with embossing or other secure means prohibiting Customers from discarding Unpermitted Waste. CONTRACTOR shall submit the label and text for Director approval prior to placing any purchase order for Containers. Item C3 of Exhibit 3A1 contains additional Container requirements.

SECTION 14 - EXECUTION OF CONTRACT**A. Execution in Counterparts**

This CONTRACT, including dated signatures on amended Exhibits and attachments to those Exhibits, may be signed by the parties hereto in any number of original separate counterparts, including both counterparts that are executed on paper and counterparts that are in the form of electronic signatures. Electronic signatures include facsimile or e-mail electronic signatures. Each executed counterpart shall be deemed an original. All counterparts, taken together, constitute the executed CONTRACT.

The parties hereby acknowledge and agree that electronic records and electronic signatures, as well as facsimile signatures, used in connection with the execution of this CONTRACT and electronic signatures, facsimile signatures or signatures transmitted by electronic mail in so-called pdf format shall be legal and binding and shall have the same full force and effect as if a paper original of this CONTRACT had been delivered had been signed using a handwritten signature. CONTRACTOR and COUNTY (i) agree that an electronic signature, whether digital or encrypted, of a party to this CONTRACT is intended to authenticate this writing and to have the same force and effect as a manual signature, (ii) intend to be bound by the signatures (whether original, faxed or electronic) on any document sent or delivered by facsimile or, electronic mail, or other electronic means, (iii) are aware that the other party will rely on such signatures, and (iv) hereby waive any defenses to the enforcement of the terms of this CONTRACT based on the foregoing forms of signature. If this CONTRACT has been executed by electronic signature, all parties executing this document are expressly consenting under the United States Federal Electronic Signatures in Global and National Commerce Act of 2000 ("E-SIGN") and California Uniform Electronic Transactions Act ("UETA")(Cal. Civ. Code § 1633.1, et seq.), that a signature by fax, e-mail or other electronic means shall constitute an Electronic Signature to an Electronic Record under both E-SIGN and UETA with respect to this specific transaction.

B. Authority to Execute

COUNTY warrants that the individual signing this CONTRACT has been duly authorized by COUNTY to sign this CONTRACT on behalf of COUNTY and has the full right, power, and authority to bind COUNTY to this CONTRACT. CONTRACTOR warrants that the individual signing this CONTRACT below has been duly authorized by CONTRACTOR to sign this CONTRACT on behalf of CONTRACTOR and has the full right, power, and authority to bind CONTRACTOR to this CONTRACT.

SECTION 15 - PERFORMANCE ASSURANCE

A. Performance Bonds, Other Security

CONTRACTOR shall secure and maintain throughout the Term and until CONTRACTOR has complied with all its obligations that survive the Expiration Date a faithful performance bond, approved by COUNTY. The performance bond must be in a form satisfactory to COUNTY or, at COUNTY's sole and absolute discretion, any alternative security acceptable to Director, including cash, certified check payable to COUNTY, certificate of deposit, or letter of credit (together, "**Performance Assurance**"), in the amount not less than \$50,000.

The Performance Assurance secures full and timely satisfaction of Performance Obligations for Collection Services.

CONTRACTOR shall provide a Performance Assurance in the amount listed in the table below for the period beginning on the Execution Date and ending on the last day of the first Contract Year.

| Service Area | Amount of Performance Assurance |
|-------------------------|---------------------------------|
| San Gabriel Valley West | \$50,000 |

Beginning on the first day of the next Contract Year, and in all subsequent Contract Years, that amount must be not less than the sum of:

- 15 percent of CONTRACTOR's Gross Receipts from Collection Services minus any Franchise Fees for the prior Contract Year;
- + 110 percent of any Franchise Fees paid by CONTRACTOR during the first six months of the prior Contract Year;
- + 110 percent of any liquidated damages assessed CONTRACTOR by COUNTY during the first six months of the prior Contract Year; and
- + Up to \$50,000, at the discretion of Director;
- = **SUM OF PERFORMANCE ASSURANCE (\$50,000 MINIMUM)**

A performance bond must be payable to COUNTY and executed by a corporate surety licensed to transact business (admitted) as a surety in the State of California. The corporate surety must have an A.M. Best Rating of not less than A:VII, unless otherwise approved by Director. The form of performance bond may not allow the bond surety to substitute another Person to perform Collection Services but must provide for payment of moneys to COUNTY to; (1) secure substitute Collection Services; (2) remedy damages incurred by COUNTY, including reasonable expenses, attorney's fees, and liquidated and compensatory damages; (3) ensure satisfaction of all Performance Obligations, including payment of Franchise Fees; and, (4) repay any money recovered from COUNTY in any bankruptcy or similar proceedings relating to CONTRACTOR. The

performance bond must be conditioned on faithful performance by CONTRACTOR of all the terms and conditions of this CONTRACT, including payment of Franchise Fees and any liquidated damages.

Each Performance Assurance must be renewed to provide for continuing liability in the above amount notwithstanding any payment or recovery thereon. At least 30 days prior to the Execution Date and 30 days prior to any renewal of the Performance Assurance, CONTRACTOR shall deliver the Performance Assurance to Director.

Director may verify the accuracy and authenticity of the Performance Assurance submitted.

B. Further Assurances

In addition to all other rights and remedies it may have, within five days of County request CONTRACTOR will provide reasonable assurances that it can timely and fully meet its obligations under this CONTRACT in any or all of in the following events:

1. Labor

CONTRACTOR is the subject of any labor unrest (including work stoppage or slowdown, sick-out, picketing and other concerted job actions).

2. Tipping Fees

CONTRACTOR does not pay an identified Solid Waste Facility for services.

3. Employee Wages

CONTRACTOR does not pay wages to its employees, provide workers' compensation insurance required by law, or pay employment-related taxes or fees.

4. County

CONTRACTOR does not pay COUNTY any amount that COUNTY has charged CONTRACTOR.

5. Meet Obligation

In the COUNTY's judgment, the occurrence of either of the following events jeopardizes CONTRACTOR's ability to timely and fully meet its obligations under this CONTRACT:

- CONTRACTOR does not regularly pay its bills when due, or
- The entering of any judgment against CONTRACTOR or any Guarantor with respect to Criminal Conduct by CONTRACTOR or Guarantor.

“Assurance of Performance” means any or all of the following actions, as COUNTY requests:

- Reduction or elimination of insurance deductibles or self-insured retention,
- Providing or increasing the size of a letter of credit, or
- Providing an additional performance bond, certificate of deposit or other instrument.

SECTION 16 - CONTRACT SERVICE AREA INFORMATION

CONTRACTOR is to use and follow the information below provided by Director.

A. Maps

1. Map of Exclusive Commercial Franchise Service Areas

B. Service Areas Data Information

1. Exclusive Commercial Franchise Service Areas Data

C. Outreach

1. Public Education and Outreach Guidelines

SECTION 17 - CONTRACTOR DOCUMENTATION

A. CONTRACTOR's Compliance with CONTRACTOR Documentation

CONTRACTOR shall provide Collection Services in compliance with the CONTRACTOR Documentation attached as Exhibit 17.

B. Changes in CONTRACTOR Documentation

1. Notice to Director

CONTRACTOR shall give Director prompt Notice of any changes in CONTRACTOR Documentation listed in item A of Exhibit 17 Contractor Documentation, after the Execution Date. CONTRACTOR shall follow Notice procedure in Part 9F of Exhibit 5. Director's receipt of those changes will be evidenced by the following acknowledgment, appended in substantially this form to the changed CONTRACTOR Documentation:

From: Director Designee
Sent: Tuesday, May 09, 2017 4:55 PM
To: waste hauler
Cc: Business Relations and Contracts Division
Subject: Service Area Name - Acknowledgement of Notice

Acknowledgment: CONTRACTOR has submitted the attached CONTRACTOR Documentation.

Director Designee
Senior Civil Engineer
Los Angeles County Public Works
Office: 626-458-3573

2. Director Approval

CONTRACTOR shall submit to Director for review and approval any changes in CONTRACTOR Documentation listed in item B of Exhibit 17 Contractor Documentation, after the Execution Date. CONTRACTOR shall follow Notice procedure in Part 5F of Exhibit 5. Director's approval will be evidenced by the following acknowledgment, appended in substantially the following form to the changed CONTRACTOR Documentation:

From: Director Designee
Sent: Tuesday, May 09, 2017 4:55 PM
To: waste hauler
Cc: Business Relations and Contracts Division
Subject: Service Area Name - Acknowledgement of Approval

Acknowledgment: I have reviewed and approved the attached CONTRACTOR Documentation

Director Designee
Senior Civil Engineer
Los Angeles County Public Works
Office: 626-458-3573

IN WITNESS WHEREOF, COUNTY has by order of its Board of Supervisors caused this CONTRACT to be signed by Director, and CONTRACTOR has caused this CONTRACT to be signed by its duly authorized officers, as of the date first written above.

COUNTY OF LOS ANGELES

By 
Director of Public Works

APPROVED AS TO FORM:

DAWYN R. HARRISON
Acting County Counsel

By 
Deputy

WARE DISPOSAL, INC.

By 
President

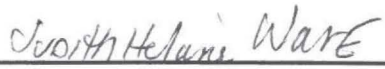
Type or Print Name

Secretary

Type or Print Name

ACKNOWLEDGMENT

A notary public or other officer completing this certificate verifies only the identity of the individual who signed the document to which this certificate is attached, and not the truthfulness, accuracy, or validity of that document.

State of California
County of Orange

On 09-20-2022 before me, Aubry Edwards, notary public
(insert name and title of the officer)

personally appeared Ben Ware,
who proved to me on the basis of satisfactory evidence to be the person(s) whose name(s) is/are
subscribed to the within instrument and acknowledged to me that he/~~she/they~~ executed the same in
his/~~her/their~~ authorized capacity(ies), and that by his/~~her/their~~ signature(s) on the instrument the
person(s), or the entity upon behalf of which the person(s) acted, executed the instrument.

I certify under PENALTY OF PERJURY under the laws of the State of California that the foregoing paragraph is true and correct.

WITNESS my hand and official seal.

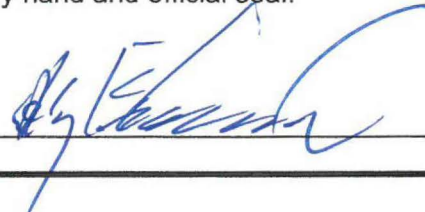
Signature 

(Seal)

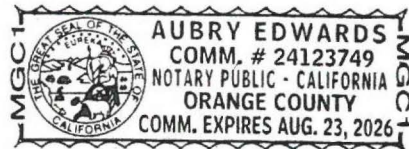

ACKNOWLEDGMENT

A notary public or other officer completing this certificate verifies only the identity of the individual who signed the document to which this certificate is attached, and not the truthfulness, accuracy, or validity of that document.

State of California

County of Orange)

On 09-20-2022 before me, Aubry Edwards, notary public
(insert name and title of the officer)

personally appeared Judith Helaine Ware,
who proved to me on the basis of satisfactory evidence to be the person(s) whose name(s) is/~~are~~
subscribed to the within instrument and acknowledged to me that he/~~she/they~~ executed the same in
~~his/her/their~~ authorized capacity(~~ies~~), and that by ~~his/her/their~~ signature(s) on the instrument the
person(s), or the entity upon behalf of which the person(s) acted, executed the instrument.

I certify under PENALTY OF PERJURY under the laws of the State of California that the foregoing paragraph is true and correct.

WITNESS my hand and official seal.

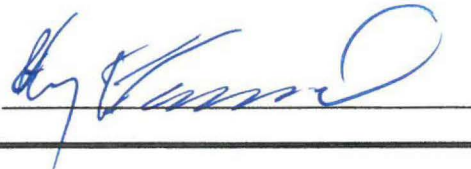
Signature 

(Seal)

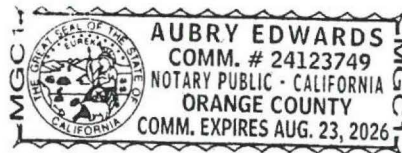

EXHIBITS TABLE OF CONTENTS

EXHIBIT 3A1 – Collection Services 1

A. Scope of Collection Services 1

B. State of California Mandatory Commercial Recycling and Organic Waste
Recycling 9

C. Containers 10

D. Solid Waste Transportation, Processing, Diversion, and Disposal 16

E. Diversion 21

F. Special Services 24

G. Method of Payment for Collection Services 29

H. Transition Roll-Out Plan 29

I. Public Education and Outreach 31

J. Additional Services 37

K. CONTRACTOR Commitments Made in Proposal 40

L. Difficult to Service Areas 41

EXHIBIT 5 – Additional Contract Obligations 42

PART 1 - GENERAL CONTRACT REQUIREMENTS 42

A. Employment Eligibility Verification 42

B. Security and Background Investigations 42

C. Consideration of Hiring COUNTY Employees 42

D. Conflict of Interest 42

E. Fair Labor Standards Act 43

F. Consideration of Hiring GAIN and GROW Participants 43

G. Record Retention and Inspection/Audit Settlement 44

H. Compliance with COUNTY's Jury Service Program 45

I. CONTRACTOR's Charitable Activities Compliance 46

J. Social Enterprise Preference Program 46

K. Local Small Business Enterprise Preference Program 47

L. Disabled Veteran Enterprise Preference Program 48

M. CONTRACTOR Responsibility and Debarment 49

N. Reporting Requirements for Improper Solicitations 51

O. COUNTY's Quality Assurance Plan 51

P. Local Small Business Enterprise Utilization 52

Q. Compliance with COUNTY's Zero Tolerance Human Trafficking 52

R. Method of Payment and Required Information 53

S. Compliance with Fair Chance Employment Practices 53

T. Compliance with the County Policy of Equity 53

U. Contractor Independence 54

V. Contractor Alert Reporting Database (CARD) 54

W. Federally Funded Work 54

PART 2 - INDEMNIFICATION AND INSURANCE 56

A. Indemnification and Release of COUNTY 56

B. Insurance 58

C. Compensation for COUNTY Costs 64

D. Alternative Risk Financing Programs 64

PART 3 - SUSPENSION; TERMINATION; DEBARMENT BREACHES AND DEFAULTS . 65

A. Notice of Breach; CONTRACTOR Cure Notice 65

B. Contractor Default. The following constitute Contractor Defaults..... 65

C. Notice of Contractor Default..... 68

D. Suspension or Termination of CONTRACT 68

E. CONTRACTOR Responsibility and Debarment 71

F. Termination For Breach Of Warranty To Maintain Compliance With County
Defaulted Property Tax Reduction Program 72

PART 4 - TRANSFER OF CONTRACT 73

A. COUNTY Consent 73

B. CONTRACTOR Demonstration 74

C. Payment of COUNTY's Transfer Costs..... 74

D. County's Reimbursement Costs of Enforcement 75

PART 5 - GENERAL PROVISIONS 76

A. Exercise of Options 76

B. Independent Status 76

C. Damage to Property and Personal Injury 76

D. Venue 76

E. Changes and Amendments 77

F. Notices 77

G. Authorized Representative of Director 78

H. Authority and Representations; COUNTY Disclaimer 78

I. Criminal Activity 79

J. Delay of Performance Obligations 80

K. Subcontractors..... 80

PART 6 - DEFINITIONS AND INTERPRETATION OF CONTRACT 81

A. Definitions 81

B. Interpretation and Construction..... 81

C. Integration..... 82

D. Governing Law..... 82

E. Severability 82

F. Interpretation..... 83

PART 7 - COMPLIANCE WITH LAWS AND REGULATIONS 84

A. Applicable Law..... 84

B. COUNTY Child Support Compliance Program 86

C. County Defaulted Property Tax Reduction Program..... 86

PART 8 - LABOR-RELATED PROVISIONS REQUIRED IN COUNTY CONTRACTS .. 87

A. Labor Code 87

B. Notices to Employees 87

C. Prohibition Against Use of Child Labor 88

D. Nondiscrimination 89

E. Safety..... 90

F. COUNTY Lobbyists..... 90

ATTACHMENT 5-8G – Authorized Representative of COUNTY’s Director 91

ATTACHMENT 5-8H – CONTRACTOR’s Representations and Warranties..... 92

A. Status..... 92

B. Statements and Information..... 92

C. No Conflicts 92

D. No Approvals Required..... 92

E. No Litigation..... 92

F. Due Diligence 93

G. Compliance with Applicable Law 93

H. Ability to Perform..... 93

I. Contingent Fees 93

J. Opportunity to Comment..... 93

K. Solid Waste Facilities..... 93

L. Contractor Documentation 94

M. Personnel..... 94

ATTACHMENT 5-9A - Definitions 95

EXHIBIT 7 – Rate Adjustments..... 115

A. Service Rates Schedule..... 115

B. Discontinued Indices..... 118

ATTACHMENT 7-1 – Rate Adjustment Example 119

A. Annual increase or decrease in CPI..... 119

ATTACHMENT 7-2- SERVICE RATES 120

A. Table 1- Commercial Rates 120

B. Table 2- Multifamily Rates 120

C. Table 3- Residential Rates..... 120

D. Table 4- Single Pass Collection 120

E. Table 5- Extra Services Fees to Customer 120

F. Table 6- Other Additional Services Rates 120

EXHIBIT 12-D2 – Liquidated Damages 121

EXHIBIT 16 – Contract Service Area Information 126

A. Maps 126

B. Service Areas Data Information 126

C. Outreach 126

EXHIBIT 17 – Contractor Documentation 136

A. Notice to Director Required..... 136

B. Director Approval Required..... 136

EXHIBIT 3A1 – Collection Services

A. Scope of Collection Services

The CONTRACTOR shall provide Collection Services to all Premises of County Commercial Franchise Customers in the Service Area(s), in accordance with Section 1 Grant of Rights and Privileges and per the Collection method indicated by the CONTRACTOR and approved by the Director.

CONTRACTOR must provide all Customers that are subject to this CONTRACT the Minimum Default Solid Waste Collection Service which includes an automatic subscription of Refuse, Recyclables, and Organic Waste Collection Services, unless the Director approves an alternate Collection method.

If the COUNTY issues waivers/exemptions to Customers as specified in Section 1B, (Exclusions from Service) in this CONTRACT, the CONTRACTOR will not be required to provide Collection Services for the excluded material type. CONTRACTOR shall assist COUNTY with Customer waiver/exemption requests as specified in Section J2.

CONTRACTOR must provide Collection Services to Premises of the following:

1. County Commercial Franchise Customers

a. *Commercial Businesses*

The CONTRACTOR shall provide such services to all Commercial Businesses regardless of whether the Customer utilizes Cart and/or Dumpsters for Collection. However, the Director in its sole discretion may allow the Authorized Residential Franchise Waste Hauler to service a Commercial Business Customer with all Carts if Director finds such service would be more efficient or cost-effective.

b. *Multifamily Premises (5 Units or More)*

CONTRACTOR shall provide such services to Multifamily Premises (5 Units or More) including mobile home parks that have Carts service per individual unit and no Dumpsters. The Authorized Residential Franchise Waste Hauler shall be the default service provider for Multifamily Premises (4 Units or Less).

c. *Multifamily Premises with Carts and Dumpsters Services*

The CONTRACTOR shall provide such services to Multifamily Premises Including a Homeowner's Association (HOA) that selects to utilize Carts for individual tenants and Dumpster Containers for common areas onsite.

d. Residential Premises with Dumpster Services

The CONTRACTOR shall provide such services to all Residential Premises who utilize Dumpster Collection Services for Refuse, Recyclables, and/or Organic Waste. This may include Residential Premises that have Manure-only Dumpster services. Additionally, Customers who are being serviced under the Residential Franchise contract (Single Family and Multifamily of 4 Units or Less) that have Carts for Collection Services but only utilize Dumpsters for Manure Collection only, can receive Manure Collection Services by either the Authorized Commercial Franchise Waste Hauler or the Authorized Residential Franchise Waste Hauler. This provision also applies to Residential Premises operating a business on the property.

2. Collection Methods

Collection methods must be in compliance with Article 3, Section 18984 of SB 1383 regulations. The Director at its sole discretion may require the CONTRACTOR to implement any Collection method as indicated in Forms PW-2 and PW-3 Schedule of Prices.

All Collection methods and Processing facilities must be approved by the COUNTY and shall meet requirements set forth under item D1, CONTRACTOR Solid Waste Designated Facility in this Exhibit.

3. Commercial, Multifamily, and Residential Collection Services

CONTRACTOR shall provide the Minimum Default Collection Service for the Collection of Solid Waste (Refuse, Recyclables, and Organic Waste) to all County Commercial Franchise Customers including to some applicable Residential Customers that utilize Dumpster services for the Collection of Solid Waste.

The Service Rates Schedule in Attachment 7-2 of Exhibit 7 includes the uniform rates that shall be applied to all Customers in each CONTRACTOR designated Service Area.

The Minimum Default Collection Service includes a minimum base rate for the level of service for Refuse which is agreed upon by the Customer and CONTRACTOR and shall be charged accordingly to the rates set forth in the Service Rates Schedule in Attachment 7-2 of Exhibit 7. The Refuse rate will automatically include a 64-gallon Cart of weekly Organic Waste Collection and a 96-gallon Cart of weekly Recyclables Collection Service per Customer, both at no additional charge unless the Customer requires service beyond the minimum. Levels of service will vary per Customer.

Additional Recycling and Organic Waste Containers

Upon Customer request, the CONTRACTOR shall provide additional Recyclables, and Organic Waste Containers at the rates listed in the Service Rates Schedule in Attachment 7-2 of Exhibit 7, provided that the additional Containers are being used by the Customer or Occupant for the purposes of setting out additional Recyclable and Organic Waste materials for regular weekly Collection Services. Additional Container rates for Organic Waste must be no greater than the Refuse rates and Recyclables rates must be no more than half of the Refuse rates as specified in the Service Rates Schedule.

The CONTRACTOR shall work with each Customer to provide the appropriate number and size of Containers for the appropriate service level and collection frequency to meet the Customer's service needs, including Container space constraints.

a. In-Home Food Waste Containers

CONTRACTOR is to provide an in-home Food Waste Container (i.e., kitchen pail) to each Occupant of a Residential Premises and Multifamily Premises. The in-home Food Waste Container should be attractive enough to place on a kitchen counter and small enough to place in a dishwasher. In-Home Food Waste Containers shall be approved by the Director. It is anticipated that Occupants would use the Container to regularly transfer Food Waste from their kitchen to the designated Collection Container (e.g., green and/or black container) and eliminate the need for a plastic bag. While the first Food Waste Container is to be provided at no additional charge, CONTRACTOR must allow the purchase of additional Containers for the fee indicated in Exhibit 7, Attachment 7-2, Extra Services Fees. CONTRACTOR may request approval from the Director to not provide in-home Food Waste Containers if selected Collection Method does not include Source Separating Organic Waste.

b. Use of Plastic Bags for Organic Waste

CONTRACTOR shall allow Customers and Occupants to place Organic Waste in clear plastic bags and place the bagged Organic Waste in the designated Collection Container, in accordance with Sections 18984.1 and 18984.2 of SB 1383 regulations. CONTRACTOR must comply with reporting requirements set forth in Section 10 Reports.

4. Collection Schedule Requirements

CONTRACTOR shall Collect Solid Waste (Refuse, Recyclables, and Organic Waste) in the Service Area from Containers, and Bulky Items, as provided in this Exhibit.

a. *Days Authorized to Collect*

Residential Collection is only permitted Monday through Friday, except following a Holiday. Commercial Collection is only permitted Monday through Saturday, except following a Holiday.

b. *Collection Hours*

CONTRACTOR shall Collect only between the hours of 7 a.m. and 7 p.m., except for Collection from Commercial Customers and Occupants in accordance with County Code, including Section 12.08.520 Refuse Collection Vehicles.

If it becomes evident that CONTRACTOR may not be able to complete its scheduled work within the required hours, CONTRACTOR shall immediately notify Director and receive approval to Collect outside of regular hours. Director may request a proposal for measures to be taken to maintain the scheduled service without delay or interruption.

CONTRACTOR shall not Collect in School Zones within 30 minutes of the school's starting time and ending times, or at any time that children are present.

CONTRACTOR shall use Reasonable Business Efforts to adjust the early morning start point of Collection routes to address and minimize Occupant complaints.

c. *Collection Frequency*

CONTRACTOR shall Collect all Solid Waste on the scheduled Collection Day(s), at least once per week from Customers. The frequency of Collection may be reduced at the discretion of Director, but it shall be implemented only if it is permitted by Applicable Laws. For example, the Collection frequency of Refuse may be reduced if Food Waste is not allowed in the Refuse Container or Recyclables Containers Collection frequency may be reduced to every other week.

Customers may increase the frequency of their Collection for an additional charge as indicated in the Service Rates Schedule in Attachment 7-2 of Exhibit 7.

d. *Collection Schedule*

CONTRACTOR shall follow the approved Collection schedule for the Service Area on the Service Days as indicated on the Collection schedule in Contractor Documentation in Exhibit 17 (Collection Schedule), or other schedule approved by Director if it significantly improves efficiencies.

For Customers that are impacted by street sweeping schedules, any proposed changes in the Collection schedule shall have the Service Day be one to two Service Days before streets are swept as provided in Director's schedule for street sweeping in the Service Area (If applicable). Director may amend this Collection schedule at any time, and CONTRACTOR shall use Reasonable Business Efforts to implement this amendment. CONTRACTOR shall prepare a Notice notifying the affected Customers and Occupants of the change and send such Notice to these Customers and Occupants upon receiving approval from Director.

e. *Missed Collections*

If Director, a Customer, or an Occupant notifies CONTRACTOR that CONTRACTOR has not Collected an Occupant's Solid Waste and not met its Performance Obligation, CONTRACTOR shall Collect at no additional charge:

- No later than 7 p.m. on the day of service, if it receives the complaint by 12 p.m.; or
- On the next Service Day, if the complaint is received after 12 p.m. on the day of service.

If CONTRACTOR believes such missed collection notifications were made in error, the CONTRACTOR can submit to the Director for approval, proof that Collection Services were provided to the Customer by submitting supporting documentation (such as GPS records, photographic evidence, etc.). In such case, the Director will review and make the final determination.

f. Holidays

CONTRACTOR shall observe the following Holidays:

- New Year's Day
- Memorial Day
- Independence Day
- Labor Day
- Thanksgiving Day
- Christmas Day

Collection shall be delayed one day for the Holiday and the remainder of the Holiday week. CONTRACTOR may Collect on Saturday of the same week for Residential Customers and Occupants and on Sunday for Commercial Customers and Occupants.

5. Non-Collection

For Collection instances described below, including when Containers are determined to contain Unpermitted Waste, contaminated Recyclables, or contaminated Organic Waste, or are overloaded (i.e., overfilled, overweight) to the extent that the Container cannot be safely lifted, where Container contents will not empty after tipping, and/or are blocked or inaccessible, the CONTRACTOR shall follow the Container Non-Collection Procedure set forth below. All reasons for not performing Collection Services shall be documented or shall be treated as a missed Collection and will be subject to the associated Liquidated Damages in Exhibit 12-D2.

a. Container Non-Collection Events

(1) Unpermitted Waste

CONTRACTOR observes the presence of Unpermitted Waste within the Containers or within the vicinity of the Set-Out Site other than any Unpermitted Waste that CONTRACTOR Collects such as Bulky Items.

(2) Unsafe Condition

CONTRACTOR observes an unsafe condition at the Set-Out Site.

(3) Solid Waste Not Placed in Container

Solid Waste not placed in a Container. Bulky Items do not need to be placed in a Container, bag, or bundle.

(4) Not at Set-Out Site

A Container or a Bulky Item that is not placed at the Set-Out Site.

(5) Exceed Weight Limitations

A Container that exceeds any weight limitations as described in Exhibit 16 item D, Customer Terms and Conditions.

(6) Inaccessible Premises

The Premises are not accessible to Vehicles.

(7) Contamination

CONTRACTOR must follow provisions indicated in the Contamination Noticing Section in item J1 of Exhibit 3A1.

(8) Delinquent Payment

The Customer has not timely paid CONTRACTOR's invoice for Collection Services in accordance with item B7 of Section 7. One week prior to removing a Container for nonpayment of Customer Service Rates, CONTRACTOR shall also leave a notice for Occupants on a Container and call, e-mail or text Customer stating the deadline for payment.

The COUNTY may request the CONTRACTOR to continue to provide Collection Services to delinquent Customers during health and safety emergencies as determined by the COUNTY (such as an earthquake, storm, riot, pandemic or when Solid Waste is accumulating at Set-Out Sites for more than a week).

(9) Unscheduled Pickup

Unscheduled Bulky Items, textiles, wood/lumber and E-waste Collection that requires advanced scheduling for Collection as indicated in item F subsection 1c, 1d & 3a of this Exhibit.

CONTRACTOR shall call, e-mail, or text Occupant by next Service Day to:

- Notify of the non-collection,
- Educate and explain why waste was not Collected, and
- Schedule the Collection.

(10) Overflowing Containers

CONTRACTOR determines that a Container is repeatedly filled beyond capacity and consistently overflowing.

b. Non-Collection Notice Procedure

(1) Non-Collection Notice

If CONTRACTOR does not Collect the Occupant's Solid Waste, the CONTRACTOR shall leave a written Non-Collection Notice when leaving the uncollected Solid Waste. The CONTRACTOR shall leave the written notice securely attached to Occupant's Container or Bulky Items unless it is unsafe to do so. CONTRACTOR shall also provide photographic evidence to the COUNTY demonstrating that the CONTRACTOR provided the written Non-Collection Notice to the Customer. CONTRACTOR will use the form of Non-Collection Notice approved by the COUNTY included in CONTRACTOR Documentation in Exhibit 17.

At a minimum, Non-Collection Notices shall provide the following information:

- The CONTRACTOR's reason for not providing Collection Service.
- Information that will allow the Customer to correct the problem.
- CONTRACTOR's telephone number for any further questions.

CONTRACTOR shall report all non-collections in Quarterly Reports submitted to the COUNTY as specified in Section 10 Reports.

(2) Communication with the Customer

Whenever Solid Waste at the Premises of a Customer is not Collected, CONTRACTOR shall contact the Customer on the

scheduled Collection day or within (24) hours of the scheduled Service day by telephone, e-mail, text message, or other verbal or electronic message to explain why their Solid Waste was not Collected.

(3) CONTRACTOR Return for Collection

Once the Customer corrects the non-collection event, and contacts the CONTRACTOR to collect their Solid Waste, CONTRACTOR shall collect Containers and/or Bulky Items within one (1) Service Day of Customer's request if the request is made at least two (2) Service Days prior to the regularly scheduled Collection Day.

Allowed only once per Calendar year, Customers that rectify the incident of the non-collection event will be granted a "one-time" no charge for the extra Collection service event ("extra pick-up"). This does not apply for unscheduled pickups as set forth in subsection a9 of this Section. Unscheduled Bulky Items, textiles, wood/lumber and E-waste shall be Collected the following week regardless if Customer or Occupant responds to the Non-Collection Notice as indicated in item F subsection 1c of this Exhibit. If the Customer repeats the offense more than once per Calendar year, Contractor may charge for the extra Collection service event ("extra pick-up"), at the applicable approved rates set forth in Attachment 7-2 of Exhibit 7, Extra Service Fees.

If the Customer does not respond to the Non-Collection Notice or rectify the incident prior to their next scheduled Collection day, the CONTRACTOR shall Collect their Solid Waste if feasible and may charge the Customer a Container violation fee, at the applicable approved rates set forth in Attachment 7-2 of Exhibit 7, Extra Services Fees. CONTRACTOR must notify the COUNTY and receive final approval before charging the Customer any extra pick-up or Container violation fees on their next invoice.

B. State of California Mandatory Commercial Recycling and Organic Waste Recycling

The CONTRACTOR shall use all Reasonable Business Efforts to assist the COUNTY to comply with all laws, including but not limited to, regulations and permit conditions, that pertain to the services provided in accordance with this CONTRACT.

At the COUNTY's request and in the format requested, the CONTRACTOR shall be responsible for providing all required information and documentation to support that all Applicable Laws within this CONTRACT are being addressed. Failure to provide this documentation as requested will be subject to the reporting requirement performance standards listed in Exhibit 12-D2.

C. Containers

1. Container Colors

All Containers for the Collection of Solid Waste (Refuse, Recycling, and Organic Waste) shall be differentiated by color and shall be consistent throughout the Service Area and shall comply with CalRecycle requirements under SB 1383. Manure Collection Containers may be provided in any color, provided that it does not conflict with SB 1383 Container color requirements and is uniform throughout the CONTRACTOR'S Service Area. All Collection Container colors shall be approved by the Director prior to usage. Pictures of Container colors shall be provided to the Director upon request.

CONTRACTOR may also comply with this Section by providing a Container or Containers to its Customers that are split or divided into segregated sections, instead of an entire Container, as long as the lids of the separate sections of a split Container comply with the Container color requirements and material limitations specified in Section 18984 of SB 1383.

Notwithstanding this subsection, the CONTRACTOR is not required to replace functional Containers, including Containers purchased prior to January 1, 2022 (or date specified in 14 CCR Section 18984.7, whichever date is later), that do not meet the following color requirements prior to the end of the useful life of those Containers or prior to January 1, 2036, whichever comes first. (Timeframe specified per 14 CCR Section 18984.7.)

Prior to ordering Containers for use under this CONTRACT, CONTRACTOR must receive approval from Director to ensure the proposed Container specifications and labels comply with Applicable Law(s) including SB 1383 regulations.

2. Split Containers

Lid and body colors of Split Carts and Split Dumpsters shall be approved by the Director at least thirty (30) days before CONTRACTOR's procurement of such Containers and shall conform with requirements of 14 CCR Section 18984.

3. Container Signage and Labeling Requirements

Carts, Dumpsters, Roll-Off Boxes, and other Containers provided by the CONTRACTOR to Customers shall be clearly identified with the different types of Solid Waste such as Refuse, Recyclables, Organic Waste, or Manure Containers, as applicable. All Containers shall display the CONTRACTOR's name (in letters not less than three (3) inches high) on the exterior of the Container to be visible when the Container is placed for use, local telephone number, website and some identifying inventory or serial number. CONTRACTOR shall place a label on Containers or provide Containers with imprinted text or graphic images, or both, on all Containers or on the lids of all Containers provided to Customers. The CONTRACTOR's labels or imprinted text and/or graphics on each Container must be clearly displayed and shall include legible text and/or graphics clear enough to read at all times, it must also indicate the primary materials accepted and the primary materials that are Container Contaminants in that Container, as required by 14 CCR Section 18984.8.

Container labels or imprinted text and/or graphics on each Container shall display the CONTRACTOR's name, local telephone number, website and some identifying inventory or serial number on the Container.

Additionally, Containers that are placed or designed to be placed on a roadway or the curb of a roadway pending Collection shall be marked with reflectors. If Containers are purchased from previous waste hauler, a reflective sticker with the new logo may be placed over the old logo but stickers must be replaced if they fade or fall off. If CONTRACTOR is reusing their own Containers, there must be a reflective sticker or paint somewhere on the Container.

All Container labels and signage are subject to Director approval, which shall not be unreasonably withheld.

4. Container Cleanings

Customers are entitled to a free Container cleaning or Container change-out in each twelve (12) month period per Container upon request. Any cleaning requests beyond the required one (1) cleaning per year will be an additional fee as prescribed in Attachment 7-2 of Exhibit 7, Extra Services Fees. Any disputes concerning the CONTRACTOR's obligation for cleaning Containers shall be resolved by the COUNTY. The COUNTY's decision on the issue shall be final.

5. Graffiti Removal

The CONTRACTOR is responsible for removing graffiti from their Containers. CONTRACTOR shall remove any graffiti reported within seven (7) calendar days upon request of Director or upon hauler identification. Failure to maintain CONTRACTOR-owned Containers in accordance with the Performance Standards shall be subject to the associated Liquidated Damages listed in Exhibit 12-D2.

6. Container Placement

CONTRACTOR shall arrange for the location of a Set-Out Site directly with Customer or Occupant. If no arrangement is made, then the default location is the curb of the street for the address of the Customer or Occupant or in the alley behind the Customer or Occupant's property.

CONTRACTOR shall return empty Containers upright and to their Set-Out Sites. CONTRACTOR shall not impede pedestrian or vehicular traffic. The Set-Out Site should be located at the curb or as otherwise provided in County Code Section 20.72.177. CONTRACTOR shall not leave Containers after being serviced in the public right of way.

7. Delivery, Removal, and Exchanges

Within seven calendar days after receiving a Customers or Occupant's request for commencement or changes in Collection of Solid Waste, CONTRACTOR shall deliver Container of the Customer or Occupant's requested capacity or replace existing Container with substitute Containers of the Customer or Occupant's requested capacity. CONTRACTOR shall not charge a fee according to the following:

a. Starting or Stopping Service

CONTRACTOR shall not charge for delivery or removal of Containers upon starting or terminating service.

b. One Annual Exchange of Containers

CONTRACTOR shall exchange one or more Containers for one or more Containers of a different size if requested by Customer or Occupant once each Calendar Year at no extra charge.

c. Multiple Exchanges of Container(s)

If a Customer asks CONTRACTOR to exchange Container(s) more than once each Calendar Year as described in item b above,

CONTRACTOR may charge Customer the amount provided in Attachment 7-2, Extra Service Fees of Exhibit 7.

CONTRACTOR shall inform Customer of the fee prior to the exchange and give Customer the option of waiting for the exchange until the next Calendar Year to avoid the charge unless waiting will have a significant impact on their Recycling or Organic Waste Diversion.

d. *Removal of Carts or Dumpsters Stored in the Public Right-of-Way*

The storage of Solid Waste is not allowed within the public right-of-way. Containers left out after Collection may be an eyesore for the community, a threat to public health, and a nuisance to traffic.

(1) Third-Party Containers

At the request of Director, for Containers not owned by CONTRACTOR, CONTRACTOR shall, at no charge to COUNTY or Customer:

- Remove any container, including Carts, Dumpsters and roll-off bins that COUNTY deems abandoned, within two Service Days of request.
- Arrange for the Disposal or Diversion of Solid Waste within the container.
- Reuse, Recycle, or resell container.
- Notify Director to confirm removal.

(2) CONTRACTOR's Containers

At the request of Director, for Containers owned by CONTRACTOR, CONTRACTOR shall, at no charge to COUNTY:

Warn

- Tag Containers with a warning Notice that Solid Waste may not be stored in the right-of-way and the further leaving out of the Containers may result in their removal and a fee to return them.

Remove Container (only upon further direction from Director)

- Provide dated photographs of Containers and make available to Customer and Director, upon request.
- Remove any Cart or Dumpster from the Right-of-Way, within two Service Days.
- On the same day as removal, contact Occupant and Customer by telephone and by text or e-mail to notify them of the removal, the reason for it, and how to have it returned.
- Charge Customer the surcharge, as provided in Attachment 7-2, Extra Services Fees of Exhibit 7. Note that this surcharge may be increased by 25 percent for each additional occurrence within the past, rolling 12 months. For example, if the first time the fee was \$20, one month later it would be \$25, three months after that would be \$31.25, but 14 months later it would be back to \$20 (or whatever the current Basic Service Rate is with applicable rate adjustments).
- Charge an additional surcharge, as provided in Attachment 7-2, Extra Services Fees of Exhibit 7, if the Set-Out Site contains Solid Waste that CONTRACTOR places inside Containers upon their return.

Return

- Return Container(s) to Occupant within two service days of Customer's willingness to pay the return fee, such as having it added to the next monthly bill.

Notify Director

- Notify Director of the status of removals, payment of surcharges, and the return of Containers.

8. Repair and Replacement

a. Identification/Reporting

CONTRACTOR shall repair or replace damaged Containers that it observes are damaged when providing service and upon request from Director, Customer, or Occupant.

b. Fee

CONTRACTOR will repair or replace Containers without cost, except in the circumstances below. CONTRACTOR may charge the

Customer for the actual cost of repair or replacement of Containers when:

- A Container is missing but Customers or Occupants do not report the theft of the Container to the police.
- The Container is damaged due to Occupant negligence such as disposing of hot ashes inside the Container or over-filling the Container so that lifting it damages the Collection Vehicle. Director's determination of Occupant negligence is final.

c. *Repair or Replacement*

CONTRACTOR shall repair or replace damaged Containers within two Service Days after CONTRACTOR observes the damaged Container or when requested by Director, Customer or Occupant. "Damage" includes missing or inoperable lids.

9. Inventory

CONTRACTOR shall maintain an adequate inventory of Containers and lids of each type and capacity to provide Customers and Occupants replacements within two Service Days of request. When determining adequacy, CONTRACTOR shall consider the nature of Set-Out Sites. For example, Carts and/or Dumpsters placed on unlevel Set-Out Sites, such as in mountainous areas without curb and gutter, may be damaged more frequently than those placed in level Set-Out Sites. Therefore, CONTRACTOR must maintain a larger inventory of Carts and Dumpsters for those areas.

CONTRACTOR shall notify Director if inventory is inadequate, including an explanation of why inventory dropped below the two-Service Day standard as mentioned in subsection 8c of this Section. For example, CONTRACTOR might submit its timely order for Containers but receive them later than manufacturer originally represented due to manufacturer's backlog or other delay.

10. Container and/or Cart Lids Purchase Option

Upon expiration of this Collection CONTRACT, COUNTY may purchase some or all entire Containers' bodies with lids, or only Cart lids, or both, at a price equal to the then book value of amortized on a straight-line basis over ten years beginning on the Execution Date. COUNTY's option includes both Containers and Cart lids then used by Customers and any in storage or in inventory as indicated in subsection 9. CONTRACTOR shall transfer or assign to COUNTY all rights necessary to give COUNTY ownership, possession and use of Containers and lids COUNTY is purchasing,

including under any Containers and lid acquisition agreement, installment sale agreement, or lease.

11. Manure Service

CONTRACTOR shall offer Manure Collection Services to Customers and shall bill the Customer as provided in the Attachment 7-2, Extra Services Fees of Exhibit 7.

12. Bear Resistant Containers

Upon Customer request, CONTRACTOR shall offer bear-resistant Carts and Dumpsters. CONTRACTOR may charge for this additional service as listed in Attachment 7-2, Extra Services Fees of Exhibit 7.

13. Green Waste Containers

Upon Customer request, CONTRACTOR shall offer Green Waste only Carts and Dumpsters. CONTRACTOR may charge for this additional service as listed in Attachment 7-2, Extra Services Fees of Exhibit 7.

If a Customer has landscaping service, separate Green Waste only Collection Container, or generates no Green Waste then such Green Waste material does not have to be included in the Organic Waste Container.

14. Alternative Container Sizes

If a Customer or Occupant requests alternate Container sizes, CONTRACTOR shall provide the type of Containers described in Contractor Documentation in Exhibit 17. For the purposes of this CONTRACT, Carts with a capacity between 95 and 100 gallons are equivalent to 0.5 cubic yards. CONTRACTOR shall provide the number of alternative Containers having the same aggregate capacity as CONTRACTOR would have provided to that Occupant. For example:

- Three 32-gallon Carts instead of one 96-gallon Cart.
- One 64-gallon Cart and one 32-gallon Cart instead of one 96-gallon Cart.

D. Solid Waste Transportation, Processing, Diversion, and Disposal

1. CONTRACTOR-Designated Solid Waste Facilities

CONTRACTOR shall transport Solid Waste only to the Solid Waste Facility or Facilities that CONTRACTOR has designated in Contractor

Documentation in Exhibit 17, for Processing, Diversion, or Disposal or those facilities as directed by Director in subsection 6 below.

The CONTRACTOR shall select Solid Waste Facilities solely in its discretion, including transfer stations and material recovery facilities, composting and Disposal facilities. CONTRACTOR shall notify COUNTY of the Solid Waste Facilities that CONTRACTOR chooses for each respective type of Solid Waste (Refuse, Recyclables, Organic Waste, Manure, Bulky Items, and E-waste). For Construction and Demolition Debris, CONTRACTOR shall only utilize facilities approved by the COUNTY for Processing Construction and Demolition (C&D) Debris. All facilities utilized by the CONTRACTOR must be approved by the COUNTY as designated in Contractor Documentation in Exhibit 17. Additionally, CONTRACTOR shall allow the County at its own expense to conduct a third-party verification for Recyclables Recovery Rate of Solid Waste Facilities and materials recovery facilities utilized. The County will provide the CONTRACTOR a one week notice with scheduling options for CONTRACTOR to select for what is best for their operation. COUNTY may utilize CalRecycle's facility diversion audits if available in efforts to meet this requirement.

CONTRACTOR may designate a Solid Waste Facility or Facilities that utilizes Conversion Technology or provides feedstock to Conversion Technology facilities. Prior to any change in designated facilities, CONTRACTOR must provide Notification to Director for approval of change. Failure to receive approval from Director will result in rate adjustments being calculated based on the less expensive of the existing and previous facility. Director will review information such as fees, distance, Recycling rates, ability to Recycle Solid Waste.

If CONTRACTOR requests to take Solid Waste to a facility that charges more, Director may approve such requests without authorizing the CONTRACTOR to pass the increased cost to the Customer. At the Director's discretion, some or all the increased costs may be passed to the Customer under special circumstances such as changing Organic Waste Diversion from a cheaper but poorly managed composting facility to a highly efficient and closer anaerobic digestion facility that is more expensive.

2. Backup Disposal Facility

a. COUNTY Direction

If the Disposal facility is not accepting permitted waste, upon COUNTY approval CONTRACTOR will transport permitted waste to a backup Disposal facility identified by the COUNTY.

b. Transport Fee

The COUNTY will pay the CONTRACTOR the following transport fee for transporting permitted waste from the transfer station to the backup disposal facility for longer haul or CONTRACTOR shall decrease rates for shorter haul as described below:

(1) Transport Fee Schedule lists both of the following amounts:

- (a) Price for transporting one ton of waste for one mile (“\$X.XX / ton-mile”) as listed in Exhibit 7, Attachment 7-2, Schedule of Prices, and
- (b) The number of round-trip miles from the transport station to the Disposal facility (“# primary Disposal facility-miles”).

The number of miles is calculated on the shortest route on which CONTRACTOR can transport waste, for example, roads that support the weight of the loaded waste transport trucks.

- (c) **Longer Haul.** If the backup Disposal Facility is farther from the transfer station than is the primary Disposal facility, then the transport service fee will be increased as follows to reflect the additional transport miles:

\$X.XX [INSERT FROM PROPOSAL] transported tons
X increased miles = \$X.XX.

- (d) **Shorter Haul.** If the back-up primary Disposal Facility is closer to the transfer Station than is the primary Disposal facility, then the transport service fee will be decreased to reflect the reduced transport miles as follows:

\$X.XX [INSERT FROM PROPOSAL] transported tons
X decreased miles = \$X.XX.

3. Facility Standards

Director reserves the right to review documentation and inspect facilities in the future and not allow use of facilities that do not meet Director’s satisfaction.

4. Processing Facility for E-Waste

CONTRACTOR shall utilize a Processing Facility to Recycle and dismantle all E-waste that it Collects into materials that meet commercial standards for marketable commodities such as metals, plastic, and glass in a facility that operates within the United States. CONTRACTOR shall not ship or utilize a Processing Facility that ships any other E-waste or E-waste components outside the United States. CONTRACTOR shall demonstrate compliance with this subsection in the form of an affidavit from the proposed E-waste recycler.

5. Processing Facility Temporary Equipment or Operational Failure Waiver

a. Notification to the County

The CONTRACTOR, or their Subcontractor (such as a Facility operator), shall notify the COUNTY immediately of any unforeseen operational restrictions that have been imposed upon the designated Solid Waste Facility by a regulatory agency or any unforeseen equipment or operational failure that will temporarily prevent the designated Solid Waste Facility from Processing and recovering different types of Solid Waste such as Recyclables, Organic Waste and Mixed Waste.

The CONTRACTOR or Subcontractor shall notify the COUNTY immediately from the time of the incident. The notification shall include the following: (i) name of designated Solid Waste Facility; (ii) the Recycling and Disposal Reporting System Number of the designated Solid Waste Facility; (iii) date the designated Solid Waste Facility became unable to Process Recyclables, Organic Waste and Mixed Waste; (iv) description of the operational restrictions that have been imposed upon the designated Solid Waste Facility by a regulatory agency or unforeseen equipment failure or operational restriction that occurred; (v) the period of time the CONTRACTOR anticipates the temporary inability of the designated Solid Waste Facility to Process Recyclables, Organic Waste, or Mixed Waste; (vi) CONTRACTOR's proposed action plan to deliver materials to an Alternative Solid Waste Facility for Processing (Contractor Documentation in Exhibit 17) or CONTRACTOR's request for a waiver to deliver Recyclable, Organic Waste, or Mixed Waste to the designated Solid Waste Disposal Facility.

b. Use of Alternative Facility or Waiver for Disposal of Materials

Upon notification by CONTRACTOR or Subcontractor of the designated Solid Waste Facility's inability to Process materials, COUNTY shall evaluate the notification and determine if County shall require CONTRACTOR to use an alternative Solid Waste Facility or allow the CONTRACTOR to Transport Recyclables, Organic Waste, or Mixed Waste to the designated Solid Waste Facility for Disposal on a temporary basis for a time period specified by the COUNTY. Upon COUNTY's decision, the COUNTY shall notify the CONTRACTOR of its requirement to use an alternative Solid Waste Facility for Processing or to use the designated Solid Waste Facility for Disposal, and the period of time that the COUNTY will allow Recyclables, Organic Waste, or Mixed Waste to be redirected to the alternative Solid Waste Facility or designated Solid Waste Disposal Facility.

Pursuant to 14 CCR Section 18984.13, the approved Disposal period shall not exceed ninety (90) days from the date the Designated Facility's Processing restriction or failure commenced. In such case, the CONTRACTOR must receive written permission from the COUNTY prior to depositing any Discarded material in a landfill.

CONTRACTOR shall maintain a record of any designated Solid Waste Facility incidents and report this information to the COUNTY in accordance with Section 10 Reports.

6. County Designation of Facility

Director reserves the right to direct Solid Waste to a specific site or facility. COUNTY will compensate CONTRACTOR for any direct costs, if any, such as increased tipping fees and transportation costs which CONTRACTOR incurs as a result of the delivery of materials to a COUNTY-designated Solid Waste Facility instead of to the Solid Waste Facility selected by CONTRACTOR. CONTRACTOR must submit verifiable evidence demonstrating increased costs.

If CONTRACTOR had been using a CONTRACTOR owned facility before being redirected to a different facility, Director will not compensate CONTRACTOR for any lost profits incurred by the CONTRACTOR as a result of being redirected to a different facility. In addition, Director will not compensate CONTRACTOR for any losses incurred to the extent that it had any general obligations to provide a minimum Tonnage to a facility (often referred to as put or pay) but will compensate CONTRACTOR for additional out-of-pocket costs directly resulting from an obligation agreed to specific to this contract. For example, if CONTRACTOR signed an agreement to bring 100,000 tons per month of Refuse to Landfill X, Director will not compensate the CONTRACTOR for redirecting waste under this contract to a different facility. But if CONTRACTOR had agreed to bring 1,000 tons of

Refuse from this Service Area to Landfill X, Director will compensate CONTRACTOR for additional out-of-pocket costs that CONTRACTOR incurs as a direct result of being redirected to a different facility.

E. Diversion

1. Reasonable Business Efforts to Divert

CONTRACTOR shall use Reasonable Business Efforts to Divert all Solid Waste that it Collects including Recyclables, Organic Waste, Manure, Bulky Items and E-waste.

2. Changes in Materials

Director may add or delete Recyclable and Organic Waste materials from the definition upon Notice to CONTRACTOR and taking into consideration that the applicable facility where such Recyclables or Organic Waste are delivered by CONTRACTOR accepts such materials added by the Director. Within 14 days of receiving that Notice, CONTRACTOR shall give Director a draft Notice informing Customers of changes in materials. Following COUNTY's approval, CONTRACTOR shall distribute those Notices to Customers and Occupants in the manner that Director requests in accordance with Item I5 of this Exhibit.

CONTRACTOR may request an adjustment to the Service Rates under item A1b of Exhibit 7, Changes in Scope of Service, including submission of documentation supporting the adjustment, to the Director. COUNTY and CONTRACTOR must agree on the adjustment.

Examples of adjustments (or no adjustments) might be:

- No Adjustment
 - No incremental or net cost of Collection or Processing.
- Possible Adjustment
 - Incremental cost of acquiring new Containers, establishing additional Set-Out Sites, and adding an additional Collection route, not offset by materials sales.
 - Additional cost to Process material.

3. Scavenging - Discouragement

CONTRACTOR shall use Reasonable Business Efforts to enforce the "Collection by Unauthorized Persons" law, pursuant to Public Resources

Code Section 41950, et seq., and County Code Chapter 20.72.196 ("anti-scavenging laws"), including the following:

Marking Recyclables Containers with language that the materials are to only be picked up by CONTRACTOR as the "authorized agent" and that CONTRACTOR is picking up the material for Recycling purposes.

CONTRACTOR shall verbally advise any Person that is observed removing Recyclable materials which have been segregated from Solid Waste materials and placed at a designated Collection location for the purposes of Collection and Recycling that such conduct is a misdemeanor, per COUNTY Ordinance, and carries civil penalties.

Instituting civil actions against a Person alleged to have violated California Public Resources Code Section 41950 for treble damages, as measured by the value of the material removed, or a civil penalty of not more than \$2,000, whichever is greater, for each unauthorized removal, in accordance with California Public Resources Code Section 41953(a).

Instituting civil actions against a Person alleged to have violated California Public Resources Code Section 41950 for a second, or subsequent time in a 12-month period, for treble damages, as measured by the value of the material removed, or a civil penalty of not more than \$5,000, whichever is greater, for each unauthorized removal, in accordance with California Public Resources Code Section 41953(b); and

Taking actions under County Code Section 20.72.196 to discourage Scavenging.

4. Prohibition on Mixing Recyclables, Organic Waste, and Refuse

Unless CONTRACTOR is obligated under this CONTRACT or approved by Director to conduct a single-pass service for Customers per item M of Section 4 to Process Refuse for recovery of Recyclables and Organic Waste, or unless as otherwise approved by Director, CONTRACTOR shall not:

- a. *Mix the contents Collected from Recyclables, Organic Waste, and Refuse Containers; or***
- b. *Dispose of Recyclables or Waste Collected, except for:***
 - (1) Incidental amounts of Recyclables or Organic Waste that an Occupant commingles with discarded Refuse;
 - (2) Contaminated Recyclables or Organic Waste that cannot be Diverted using Reasonable Business Efforts if

CONTRACTOR has previously exercised Reasonable Business Efforts to provide Occupant education with respect to reducing that contamination as set forth in the CONTRACTOR's approved Contamination Monitoring Plan submitted in accordance with Contractor Documentation in Exhibit 17.

5. Residuals

a. Minimize Quantity of Residuals

CONTRACTOR shall not use facilities that have a significant quantity of Solid Waste residuals remaining after Processing Recyclables and Organic Waste, as determined by Director, including considering operating and recovery efficiencies and maximum levels of residuals that CalRecycle may establish to qualify the Processing as Diversion.

6. Organic Waste Reduction

CONTRACTOR is required to assist COUNTY to comply with all Applicable Law(s), including SB 1383 which requires the State to achieve Organic Waste Disposal reduction targets.

COUNTY intends to have Organic Waste Diverted from landfills at the start of this CONTRACT. However, COUNTY reserves the right to either delay implementation, stop, or start Organic Waste Diversion at any time. Therefore, if there is a delay or discontinuation of Organic Waste Collection Services, the CONTRACTOR must adjust the Customer's Service Rates and it shall include the Organic Waste waiver discounted rate set forth in Attachment 7-2 of Exhibit 7, Service Rates Schedule.

COUNTY will allow various Collection methods as indicated in 14 CCR Section 18984: Combined Organic Waste Collection Services. CONTRACTOR must submit Collection method proposal along with a corresponding bid price.

7. Organic Waste Processing and Capacity

a. Securing Capacity

CONTRACTOR shall secure adequate, verifiable Diversion capacity to process Organic Waste solely for the CONTRACTOR's Service Area, and in compliance 14 CCR Section 18992.1.

b. Proof of Guaranteed Organic Waste Processing Capacity

CONTRACTOR must provide the COUNTY with a copy of a letter or an agreement from Organic Waste Processing Facility(ies) that Process Organic Waste, to demonstrate proof of guaranteed Organic Waste Processing capacity that has been secured to Process all of the Organic Waste Collected in the CONTRACTOR's Service Area. If the CONTRACTOR owns the facility, CONTRACTOR must provide a letter to the COUNTY that the facility guarantees capacity to Process all of the Organic Waste Collected in the CONTRACTOR's Service Area. This shall be provided by CONTRACTOR in Contractor Documentation in Exhibit 17.

8. SB 1383 Compliance

Facilities to which CONTRACTOR transports Organic Waste must be compliant with SB 1383 requirements in 14 CCR Section 18983.1(b), except that land application is not allowed under this CONTRACT. Land application will only be allowed with written approval by Director due to a lack of other viable facilities.

9. Mixed Waste Processing

If CONTRACTOR utilizes a Mixed Waste Collection method, CONTRACTOR shall transport all Mixed Waste that it Collects to an approved High Diversion Organic Waste Processing Facility designated in Contractor Documentation in Exhibit 17.

CONTRACTOR shall utilize an approved High Diversion Organic Waste Processing Facility that is in compliance with SB 1383 regulations, as defined in 14 CCR Section 18982(a)(33).

F. Special Services

CONTRACTOR shall provide the services prescribed in this Section without additional cost to Customers or charge to COUNTY except for item F4 of this Section, Scout Service.

1. Special Services to Residential and Multifamily Customers

a. Sharps Collection

Within one week of a Customer or Occupant request, CONTRACTOR shall provide the Occupant, without charge, with the following:

(1) Four Sharps Containers per Year

A Sharps Container that has at least a one-gallon capacity (up to four per Contract Year) for discard of Sharps in accordance with any Federal, State, and local laws and regulations; and,

(2) **Collect or Pre-Paid Mailer**

CONTRACTOR shall also Collect Sharps Container or provide a prepaid postage container for mailing back the approved Sharps Container in accordance with any Federal, State, and local laws and regulations.

CONTRACTOR shall Collect, transport, and Dispose of materials, without charge, in accordance with any Federal, State, and local laws and regulations.

b. Holiday Tree Collection

CONTRACTOR shall Collect, transport, Process, and Divert all holiday trees such as Christmas trees discarded at any Customer's Container Set-Out Site, on or before the Customer's next regularly scheduled Collection day:

- (1) During the period beginning December 26 and ending January 14 or
- (2) Another period established by COUNTY not to exceed four weeks, and at a Customer's request.

c. Bulky Item Collection

CONTRACTOR must provide the default service which is the Maximum Amount of Collections Per Year (tiered approach) and the Director reserves the right to direct the CONTRACTOR to pick-up an unlimited amount at an adjusted rate as listed on Attachment 7-2, Other Additional Services of Exhibit 7.

Additionally, upon Director request, CONTRACTOR shall Collect any Bulky Items that have been placed at the Customer's Set-Out Site even if the Customer failed to notify CONTRACTOR upon 24 hours in advance. If such Bulky Item materials that are Collected are identified by either the CONTRACTOR or Director to belong to the Customer and/or Occupant of the Premises, CONTRACTOR shall record the Bulky Item Collection incident and count it towards the Customer's Maximum Collection amount allowed per year, as referenced in the chart below.

Service Options:

Maximum Amount of Collections Per Year (Tiered Approach)

CONTRACTOR shall provide a specified maximum amount of Bulky Item pick-ups per year at no charge, depending on the Multifamily Premises and its number of units, as specified in the chart below. This also applies to Residential Customers and are identified under (1) one unit. If the Multifamily Premises and/or the Residential Customer exceeds the maximum Collection pickups amount per year, CONTRACTOR may charge for the additional Bulky Item pickups as indicated Attachment 7-2, Extra Services Fees of Exhibit 7.

| SF and MF Premises with Number of Units | Maximum Collection Pickups (no additional cost to Customer) |
|--|--|
| MF Premises with 150+ units | Up to 50 per year No Charge |
| MF Premises with 101-149 units | Up to 40 per year No Charge |
| MF Premises with 50-100 units | Up to 30 per year No Charge |
| MF Premises with 25-49 units | Up to 20 per year No Charge |
| MF Premises with 1-24 units *1-unit accounts for a Residential Customer | Up to 10 per year No Charge |

CONTRACTOR shall Collect up to ten Bulky Items including textiles, wood, lumber and E-waste as prescribed in subsection d below, upon 24 hours advance request of a Multifamily Customer or Residential Customer on that Customer's next regularly scheduled Collection day or other date agreed to between that Customer and CONTRACTOR at that Customer's regular Set-Out Site for placing Solid Waste Containers but not in any roadway or other public right of way. For items set out without notice, CONTRACTOR shall not immediately Collect but rather shall perform the following:

- Tag items with a Non-Collection Notice describing Notice requirements, and
- Contact Occupant, by next Service Day as indicated in item A6 under subsection a9 of this Exhibit.
- The following week Collect regardless of Notice by Customer or Occupant.

Unlimited Collection

The COUNTY may require the CONTRACTOR to Collect Bulky Items at unlimited number of times per year from each dwelling unit receiving service, and unlimited quantity of Bulky Items per pickup at an adjusted rate as listed on Attachment 7-2, Other Additional Services of Exhibit 7.

d. Special Recyclable/Reusable Items Collection

In accordance with SB 1383, CONTRACTOR each Calendar Year shall Collect and use Reasonable Business Efforts to Divert the following items along with Bulky Items Collection Services as described in items F1c and F3a of this Exhibit ("Special Recyclable/Reusable Items"):

(1) Textiles

- Clothing - Unlimited quantities of bagged/bundles reusable clothes.
- Other Textiles - Up to five bags/bundles not exceeding 70 pounds of textiles other than reusable clothes.

(2) Wood and Dry Lumber

- Up to two bags/bundles of wood and dry lumber bound or in Containers, not longer than four feet in length or more than 70 pounds in weight and does not contain nails.

(3) E-waste

- Unlimited items of electronic waste that is powered by a plug or battery such as computer, telephones, and televisions.

2. Priority Pickups at Director's Request

Each Calendar Year, CONTRACTOR shall Collect Solid Waste Discarded in the Public Right-of-Way according to circumstances below. Collection requests may be at different locations within the CONTRACTOR's Service Area.

a. By End of Next Service Day

CONTRACTOR shall Collect up to 10 times by the end of the next Service Day after Director's request or other time agreed to between Director and CONTRACTOR.

b. On Same Day

CONTRACTOR shall Collect up to 5 times on the same day of Director's request or other time agreed to between Director and CONTRACTOR.

c. Special Cleanup Events Services

At Director's request, CONTRACTOR shall provide Containers such as Roll-offs, Carts, Dumpsters, Cardboard boxes in type, number, and capacity (up to 80 cubic yards) for discards of Solid Waste for one community cleanup project or public event located throughout the Service Area during any 12-month period. CONTRACTOR may be required to replace filled Containers during the event if directed to do so by Director prior to the event and shall be responsible for removing any Refuse that is left alongside of, rather than inside, the Containers. CONTRACTOR shall Collect Containers at the end of the event, the next day, or other date agreed to between Director and CONTRACTOR. Event participants will be instructed to gather bags into piles at the end of the event. CONTRACTOR shall provide all the necessary staffing, labor, Vehicles, Containers, and other equipment, and materials or supplies (such as plastic bags in portable Containers).

3. Special Services for Commercial Customers

a. Bulky Item Pickups for Commercial Customers with No Additional Charge

CONTRACTOR shall collect up to ten Bulky Items including textiles, wood, lumber and E-waste from Commercial Customers no more than six times per Calendar Year at no additional charge. If the Customer exceeds the six Bulky Item Collections per Calendar Year, CONTRACTOR shall charge for the additional Bulky Item pickups service as stipulated in Attachment 7-2, Extra Services Fees of Exhibit 7.

CONTRACTOR shall Collect Bulky Items including textiles, wood, lumber and E-waste, upon 24 hours advance request of a Commercial Customer who subscribes to Collection Services for Commercial Premises, on that Customer's next regularly scheduled Collection day or other date agreed to between that Customer and CONTRACTOR at that Customer's regular Set-Out Site for placing Solid Waste Containers but not in any roadway or other public right of way.

For items set out without notice, CONTRACTOR shall not immediately Collect but rather shall perform the following:

- Tag items with a Non-Collection Notice describing Notice requirements, and
- Contact Occupant, by next Service Day as indicated in item A5 under subsection a9 of this Exhibit.
- The following week Collect regardless of Notice by Customer or Occupant.

CONTRACTOR shall use Reasonable Business Efforts to Recycle Bulky Items including textiles, wood, lumber, and E-waste.

Additionally, upon Director request, CONTRACTOR shall Collect any Bulky Items that have been placed at the Customer's Set-Out Site even if the Customer failed to notify CONTRACTOR upon 24 hours in advance. If such Bulky Item materials that are Collected are identified by either CONTRACTOR or the Director to belong to the Customer and/or Occupant of the Premises, CONTRACTOR shall record the Bulky Item Collection incident and count it towards the Customer's six Bulky Item Collections allowed per year, as indicated above.

4. Scout Service

CONTRACTOR shall provide Scout Service at the request of the Customer or if necessary and agreed by the Customer. The cost of providing this service shall be stipulates in Attachment 7-2, Extra Services Fees of Exhibit 7.

G. Method of Payment for Collection Services

CONTRACTOR shall bill Customers directly for Collection Services in accordance with items A and B of Section 7.

H. Transition Roll-Out Plan

1. Transition from Non-Exclusive Commercial Franchise System to Exclusive Commercial Franchise System

Upon CONTRACT Execution Date, the CONTRACTOR shall submit a transitional plan within 90 days for transitioning Non-Exclusive Commercial

Franchise Customers to the Exclusive Commercial Franchise System. The transition plan shall be designed by the CONTRACTOR and approved by the COUNTY prior to implementation. CONTRACTOR shall submit a plan in accordance with the requirements set forth below and CONTRACTOR shall provide the final approved plan in Contractor Documentation in Exhibit 17.

The Transition Plan shall include:

1. Timelines and tasks for the transition period and process.
2. The coordination plans between the newly awarded CONTRACTOR and the existing operating haulers of the Non-Exclusive Commercial Franchise system.
3. The schedule for the transfer of Customer accounts, including removal or transfer of waste Containers and other equipment, and the replacement of Containers or other equipment to align with new program services and other requirements as stipulated in the CONTRACT. Prior to removing or transferring Collection Containers, the CONTRACTOR shall ensure Customers continue to have Collection Services without disruption in service and shall ensure the Customer has Collection Containers at all times. CONTRACTOR shall adhere to additional requirements set forth under item B6 of Section 2 Term of Contract.
4. The Waste Hauler Welcome Package from the CONTRACTOR to its Customers located in their Service Area including all items listed on the Waste Hauler Welcome Package checklist as indicated in item C of Exhibit 16.

As part of the transition process from the existing Non-Exclusive Commercial Franchise system to the Exclusive Commercial Franchise System the CONTRACTOR shall:

- Assist with the identification and/or removal of unpermitted or unauthorized waste haulers servicing Customers in the County unincorporated communities past the transition period.
- Ensure Customers do not experience a lapse in service .

2. Transition for the Exclusive Commercial Franchise System

At least 30 days Prior to the Execution Date, CONTRACTOR shall provide to Director for approval a transition plan, which shall include both timelines and tasks. CONTRACTOR shall submit a plan in accordance with Contractor Documentation in Exhibit 17, and shall address items such as:

- Ordering Vehicles and/or Containers;
- Vehicle and/or Container delivery from manufacturer;
- Container assembly;

- Distributing Containers to Customers and Occupants;
- Public outreach and education activities;
- Determining routes;
- Training route drivers;
- Collecting old Containers; and

CONTRACTOR shall implement the approved transition roll-out plan for an orderly transition of Solid Waste Collection Services from one contractor to another.

CONTRACTOR shall cooperate and work with outgoing and future contractor of Collection Services to ensure a smooth transition. CONTRACTOR shall agree that if necessary for the orderly transition of Collection Services to:

- Collect Solid Waste from outgoing CONTRACTOR's Containers;
- Allow outgoing CONTRACTOR to Collect from Containers;
- Service, remove, and store outgoing contractor's Containers after transition;
- Allow future CONTRACTOR to Collect from Containers after the termination of CONTRACT; and
- Continue Occupant's services, Container quantity and sizes, and discounts from outgoing CONTRACTOR's customer service list, including not providing Containers to addresses not utilizing outgoing CONTRACTOR's services.

In general, CONTRACTOR should match the service levels provided to Customer/Occupants under the previous contract.

Director shall have the final say to require transition services agreement between outgoing CONTRACTOR and future contractor.

I. Public Education and Outreach

CONTRACTOR shall develop, disseminate, and conduct comprehensive public education and outreach regarding services to maximize Diversion of Recyclables, Organic waste, Bulky items, Sharps, and E-waste. The public education and outreach components shall include the following:

1. Customer Terms and Conditions

Before commencing Collection Services and annually thereafter by July 1, CONTRACTOR shall provide a Terms and Conditions to Customers and Occupants, substantially in the form included in Exhibit 16 and approved by Director. This also includes a Subscription Order Form and Bill of Rights.

CONTRACTOR shall distribute to Customers and Occupants a copy of the Terms and Conditions upon request.

Director may change the form and content of Terms and Conditions after Notice to CONTRACTOR. CONTRACTOR may change the form of Terms and Conditions only with Director's prior written approval in accordance with item B2 of Section 17.

2. Site Visits and Waste Assessments

All Customers shall receive an on-site site visit and waste assessment, by the CONTRACTOR, prior to delivery and service of Containers under this CONTRACT. The purpose of the waste assessment is to capture the materials generated at the Customer location, identify means of increasing waste diversion, and setting goals for future Diversion practices. CONTRACTOR shall provide recommendations to their Customers on reducing, or 'right-sizing', Refuse Collection Services to account for materials diverted through the CONTRACTOR provided Recycling program. Each onsite waste assessment shall include, but is not limited to:

- Pictures of materials discarded in all Containers
- Characteristics of establishment type
- Written recommendations for optimal service levels for Solid Waste Collection (Refuse, Recyclables and Organic Waste), and future Diversion programs or opportunities
- Outreach and education materials appropriate to the establishment type
- On-site training for Commercial Customer's staff, including: management, kitchen staff, service employees, and janitorial staff; and Multifamily Customers' staff, including: the Property Manager, janitorial staff, maintenance, and any other on-site staff members or contractors that handle Discarded Materials
- Determination of signage placement
- Determination of any on-going training needs
- Determination of any access needs
- Documentation of any special service needs, (i.e., seasonal, automated on-call compactor, etc.)
- Documentation of records of communications with the Customer and/or Occupant.

For each site visit and waste assessment conducted by the CONTRACTOR, the CONTRACTOR shall include documentation of the items listed above. The COUNTY reserves the right to request CONTRACTOR's documentation of additional information and shall authorize the format for required information. The CONTRACTOR shall report all site visit activities as indicated in Section 10 Reports.

3. Ongoing Site Visits and Waste Assessments

The CONTRACTOR, at its own expense, is required to provide a follow-up site visit and waste assessment within one year of the initial site assessment and then subsequent assessments shall be provided every other year. The COUNTY may request site assessments to be provided once per year for select Customers. CONTRACTOR shall follow the site visit and waste assessment requirements as set forth in item I2 above.

4. Outreach and Education for First Customer Visit

In initial contact with Customers, the CONTRACTOR shall provide a Welcome Packet that includes, but is not limited by, the following items:

- Letter from Director
Within 30 days after the Award Date or other date designated by Director, CONTRACTOR shall print and first-class mail Bilingual letters written by Director, notifying Customers and Occupants that the CONTRACT was awarded to CONTRACTOR. CONTRACTOR shall be responsible to pay for the cost of producing and mailing these letters.
- Letter from CONTRACTOR
Within 60 days prior to the Commencement Date or other date designated by Director, CONTRACTOR shall prepare and first-class mail a Bilingual letter to all Customers and Occupants introducing themselves, explaining the transition, and announcing upcoming community meeting dates, and other pertinent information.
- Subscription Order Form including rate schedules (including Extra Services Fees)
- Description of the Los Angeles County Exclusive Commercial Franchise system, including the Collection Service Area, CONTRACTOR name, contact information for billing inquiries location of customer service center
- Customer Bill of Rights and Responsibilities
- Newsletter
- Instructions regarding compliance with the Mandatory Commercial Recycling and Mandatory Commercial Organics Recycling laws, as well as any other waste diversion requirements of state law, including requirements for Source Separating materials into different Containers in accordance with the CONTRACTOR's Collection methods in order to comply with SB 1383 regulations.
- Training document on how to properly sort Organic Waste and Recyclables.
- Los Angeles County's Food DROP Program information including website link

The CONTRACTOR is required to provide these materials that will be developed electronically by the COUNTY and shall be delivered electronically or in print by the CONTRACTOR at the CONTRACTOR's expense. Correspondence distribution method shall be at the sole discretion of the Director.

5. Ongoing Customer Education and Outreach

Annually, the CONTRACTOR, at its own expense, shall disseminate, and conduct comprehensive public education and outreach regarding services to maximize Diversion of Recyclables, Organic Waste (includes Food and Green waste), Bulky items, Sharps, and E-waste. Additionally, at a frequency no more than once per month, the CONTRACTOR is required to disseminate all outreach materials that the COUNTY provides to the CONTRACTOR to distribute to their Customers.

The public education and outreach components shall include the following:

- Collection Method Description
Option 1: For a three-Container or two-Container system: Information on the Customer's requirements to properly separate Recyclables and Organic Waste, or if applicable the Collection of Mixed Waste (Two-Container) and place such materials in appropriate Containers pursuant to this CONTRACT, SB 1383 Regulations, and all other Applicable Law(s).
Option 2: For a one-Container system: Information indicating that the Recyclables and Organic Waste Collected in the Collection Containers are being Processed and recovered at an approved High Diversion Organic Waste Processing Facility.
- Subscription Order Form including rate schedules (including Extra Services Fees).
- Information regarding Self-Hauling requirements such as Self-Haulers must register with the County and submit a self-management plan to the County. Customers may compost Organic Waste on-site or send Organic Waste to a Community Composting operation, they may also utilize a third-party to Collect, transport, or Divert their Organic Waste.
- Information to Customers on the benefits of source reduction and reuse of materials including methods of how to prevent excess Solid Waste generation.
- Information on how Organic Waste is being Diverted by the CONTRACTOR.
- Information regarding the methane reduction benefits of reducing the landfill Disposal of Organic Waste.
- Publications regarding COUNTY's Edible Food donations program, Food DROP, for the donation of Edible Food.

- Reminders of the customer service center location, and COUNTY's customer service phone number and website.

This communication should be given either electronically or in printed form and it may be in the form of a flyer, postcard, or service brochures subject to the review and approval of the COUNTY. Printed outreach materials will be at no more than 5 sheets of paper per outreach material.

6. Bi-annual Newsletter

Twice each year, CONTRACTOR shall prepare promotional and educational newsletters in the bilingual form required by the Director promoting Solid Waste reduction, Recycling, and Organic Waste Diversion. CONTRACTOR shall submit the materials to Director for review during the following seasons:

- (1) Spring/Summer
- (2) Fall/Winter

Such newsletters may be provided by the COUNTY for the CONTRACTOR to distribute to its Customers.

Within 30 days of Director's accepting the materials CONTRACTOR shall distribute them to its Customers, which may be electronically, or upon Customer requests:

- (1) via the U.S. Postal Service with prepaid postage, or
- (2) door-to-door delivery service to Customer's Premises.

7. Education Materials for Property and Business Owners and Tenants

CONTRACTOR shall annually provide Property Owners and Commercial Business owners with public education materials for their distribution to all employees, contractors, tenants, and Customers of the properties and businesses. The CONTRACTOR's public education materials shall include, at a minimum, information about Organic Waste recovery requirements and proper sorting of Discarded materials and shall reflect content requirements described in item I5 of this Exhibit. CONTRACTOR shall provide the following education materials but are not limited to, welcome packets, flyers, and signs. A Commercial Business or Multifamily Property Owner may request these materials more frequently than the standard annual provision if needed to comply with the requirement of 14 CCR Section 18984.10 for Commercial Businesses and Multifamily Property Owners to provide educational information to new tenants and employees before or within fourteen (14) days of occupation of the Premises. In this case, the Commercial Business or Multifamily Property Owner may request delivery of materials by contacting the CONTRACTOR's customer service

department by no later than two (2) weeks in advance of the date that the materials are needed.

8. Community Meetings

CONTRACTOR must attend and present at community meetings/events upon Director's request at the hourly rate stipulated in Attachment 7-2, Other Additional Services of Exhibit 7.

Upon Director's sole discretion, the format of the meeting shall be either in-person or over the Internet using a Director-approved software application.

9. Additional Outreach

CONTRACTOR shall visit in-person, call, send an e-mail or text, or other means to inform a Customer or Occupant of services or issues, as requested by Director. For example, CONTRACTOR shall speak to an Occupant that contaminates a Container or frequently leaves a Bulky Item at the Set-Out Site without calling to request Collection.

10. Bilingual Correspondence

CONTRACTOR shall develop all written materials in both English and Spanish and may be requested to provide additional bilingual correspondence up to 4 languages total. Upon COUNTY request, Contractor shall provide materials in additional languages beyond those specified in this Section in response to shifting demographics within the County; updates to State requirements or Applicable Law(s); or any other reason deemed appropriate by the COUNTY.

11. Social Media

CONTRACTOR shall reach out to Customers and Occupants and make information available regarding Contract Services by current social media and the following means approved by Director, such as: Facebook, Twitter, Instagram, and NextDoor.

12. Contractor Assistance with County Educational Efforts

CONTRACTOR acknowledges that they are part of a multi-party effort to operate and educate the public about the County's Municipal Solid Waste (MSW) Management Services. CONTRACTOR shall cooperate and coordinate with the Director on public education activities to minimize duplicative, inconsistent, or inappropriately timed education campaigns. The CONTRACTOR shall cooperate with and shall not impede, interfere, or attempt to impede or interfere with the implementation, expansion, or

operation of public education and outreach programs or campaigns conducted by the COUNTY or their designee.

CONTRACTOR shall obtain approval from the Director on all CONTRACTOR-provided public education materials outside of the COUNTY's outreach and education plan, including, but not limited to: print, radio, television, or internet media before publication, distribution, and/or release. The COUNTY shall have the right to request that CONTRACTOR include COUNTY identification and contact information on public education materials and approval of such requests shall not be unreasonably withheld.

J. Additional Services

1. Contamination Monitoring

a. *Collection Route Reviews*

The CONTRACTOR shall implement a Contamination Monitoring Plan in compliance with the requirements of SB 1383 (14 CCR Section 18984.5), the CONTRACTOR must follow and utilize the approved Contamination Monitoring Plan submitted in accordance with item Contractor Documentation in Exhibit 17.

The CONTRACTOR may amend their submitted plan subject to Director approval.

Route Review means a visual inspection of Containers along a hauler route for the purpose of determining container contamination and may include mechanical inspection methods such as the use of cameras.

b. *Contamination Noticing*

The CONTRACTOR shall follow the same procedures as noted in the Section above, under Contamination Monitoring: Collection Route Reviews, where CONTRACTOR's personnel observed Container Contaminants not solely found during the Collection Route Reviews (i.e., on regular scheduled service routes).

c. *Adequate service Level*

The CONTRACTOR shall review and make recommendations for the number and size of the Customer's Organic Waste Containers to ensure an adequate level of service for the amount of Organic Waste generated, to ensure proper separation of materials and containment of materials.

d. Reporting Requirements

CONTRACTOR shall maintain records and report to the COUNTY quarterly regarding contamination monitoring activities and actions taken, in accordance with Section 10 Reports.

2. Customer Waiver Requests

a. Inspections for Waiver Qualification

CONTRACTOR shall assist the COUNTY with Customer waiver requests including the following waiver-related responsibilities in a timely manner:

- When requested by their Customer, provide waiver application(s).
- Collect and review waiver application and proof from Customer.
- Determine the Customer's initial qualification for waiver(s) and provide determination(s) to the COUNTY.
- Final Customer waiver qualification shall be determined by the COUNTY. CONTRACTOR shall keep a record of Customer waiver applications, those approved and not approved including proof of circumstances justifying the waiver and the CONTRACTOR's recommendation for approval or disapproval.
- CONTRACTOR shall provide Records as needed (monthly/quarterly), and upon reasonable request related to the Customer's waiver application(s).
- CONTRACTOR shall retain records of waiver applications and approvals for a minimum of three years.

b. Waiver Terms and Additional Information

- Customer waivers may be valid for up to five years unless otherwise stated
- Waivers may be revoked or cancelled without cause by the COUNTY.
- The COUNTY holds the right make final decisions on approval of a waiver. Including conducting additional assessments to ensure waiver applicability.
- The COUNTY may stop offering waivers or add new waivers at any time without notice.
- The COUNTY retains the right to amend waiver requirements. Amendments to waiver requirements may be applied to

existing approved waivers resulting in different approval determinations.

- Customers may submit a waiver application only once per year for approval for each type of waiver. If a waiver was not approved, then a waiver application may not be resubmitted for that same Customer, location, and waiver type, until one year after the date on the denial notice. Multiple applications may not be submitted by different Persons for the same waiver type for same account or property.

c. Customer Waiver Types and Qualifications

(1) De Minimus (Available to Commercial Accounts Only)

Section 18984.11 of the SB 1383 Regulations allows a Commercial Customer to waive their Organic Waste subscription if they produce little to no Organic Waste.

To qualify a Commercial Customer must fall under one of the following thresholds and provide any necessary documentation or supporting evidence:

1. The Commercial Customer produces MORE than 2 cubic yards of Refuse per week and produces LESS than 20 gallons of Organic Waste (green container) or Recyclables (blue container) per week.
2. The Commercial Customer produces LESS than 2 cubic yards of Refuse per week and produces LESS than 10 gallons of Organic Waste (green container) or Recyclables (blue container) per week.

Change in Customers' Service Levels

For those Customers that have been granted a waiver, the CONTRACTOR shall notify the COUNTY if the Customer has exceeded the above thresholds within (7) Service Days. Upon receiving approval from the COUNTY, the CONTRACTOR shall modify the Customer's service level by the next Collection day and shall incorporate the new rate for the new service level in their next billing statement.

(2) Physical Space (Available to Commercial or Multifamily Accounts Only)

Allows a Commercial Customer or Multifamily property (of five units or more) to waive their Organic Waste subscription in either a Three-Container or Two-Container Collection system, if the Commercial property or Multifamily property lacks adequate space for a separate Organic Waste Container.

- CONTRACTOR shall first investigate and pursue other ways to comply with Organic service requirements prior to approving a Physical Space Waiver, including but not limited to, consulting with the Customers to adjust their service levels to accommodate an Organic Waste Container.
- Approved Physical Space Waivers as a result of an enclosure's size shall be flagged and reported to the COUNTY.
- CONTRACTOR shall demonstrate proof of inadequate space for a separate Organic Waste Container by means of photographs; additional proof may be requested by the COUNTY.

3. Emergency Services

CONTRACTOR shall provide Municipal Solid Waste (MSW) Management Services requested by COUNTY in health and safety emergencies (such as an earthquake, storm, or riot, or when Solid Waste is accumulating at set-out sites for more than a week). CONTRACTOR shall charge COUNTY no more than what CONTRACTOR charges its Customers for the same frequency and capacity of service, unless Director authorizes different charges upon request of and cost substantiation by CONTRACTOR. Upon request of COUNTY, CONTRACTOR shall give COUNTY, California or Federal officials information that is related to cost of providing the emergency services (such as number or amount of Vehicles, fuel, employees, Tonnage and Disposal fees).

4. Procurement of Recovered Organic Waste Products

CONTRACTOR shall assist the COUNTY in meeting the procurement obligations for SB 1383's Procurement of Recovered Organic Waste Products. Contractor shall ensure recovered Organic Waste products are made from California, as defined in 14 CCR Section 18982(a)(60). CONTRACTOR must follow and utilize the approved plan for the Procurement of Recovered Organic Waste Products as submitted in accordance with Contractor Documentation in Exhibit 17.

CONTRACTOR shall maintain records of all procurement activities and shall report this information in accordance with Section 10 Reports.

K. CONTRACTOR Commitments Made in Proposal

CONTRACTOR shall fully and timely satisfy any additional Performance Obligations set forth in Contractor Documentation in Exhibit 17, from its proposal to Director for procurement of this CONTRACT.

L. Difficult to Service Areas

If CONTRACTOR is unable to Collect Refuse, Recyclables, Organic Waste with a standard automated Collection Vehicle, CONTRACTOR shall use an alternative size or type of Vehicle as necessary including manual or other form of Collection to ensure Collection Services. Additionally, CONTRACTOR may be able to use a standard Collection Vehicle but the rate of Collection is significantly slower , in which case also may use an alternative Vehicle. Areas that are difficult to service include those with narrow streets, alleys and bridges, one-way narrow streets, steep roadway gradients, limited roadway curve radii (tight curve), thin pavement thicknesses, unimproved (dirt) roadway surfaces, and variable vertical and horizontal clearances.

For Customers that are located in difficult to Service Areas, CONTRACTOR must submit to the Director a written request for use of a non-automated Collection Vehicle to provide Collection Services. The CONTRACTOR must provide the Director supporting documentation which should include Customer addresses, route maps, and/or pictures justifying this request. The COUNTY shall review and approve or deny such request, in its sole discretion. If approved, CONTRACTOR may be able to use an alternative Vehicle such as a non-automated Collection Vehicle to provide Collection Services and may charge the Customer a difficult to service fee per the rate schedule in Attachment 7-2 Extra Services Fees of Exhibit 7.

EXHIBIT 5 – Additional Contract Obligations

PART 1 - GENERAL CONTRACT REQUIREMENTS

A. Employment Eligibility Verification

1. CONTRACTOR warrants that it fully complies with all Federal and State statutes and regulations regarding the employment of aliens and others and that all its employees performing work under this CONTRACT meet the citizenship or alien status requirements set forth in Federal and State statutes and regulations. CONTRACTOR shall obtain, from all covered employees performing services hereunder, all verification and other documentation of employment eligibility status required by Federal and State statutes and regulations including, but not limited to, the Immigration Reform and Control Act of 1986 (P.L. 99-603), or as they currently exist and as they may be hereafter amended. CONTRACTOR shall retain all such documentation for all covered employees for the period prescribed by law.
2. CONTRACTOR shall defend and hold harmless, COUNTY of Los Angeles, its Special Districts, Elected Officials, Officers, Agents, Employees, and Volunteers sanctions and any other liability which may be assessed against CONTRACTOR or COUNTY or both about any alleged violation of Federal or State statutes or regulations pertaining to the eligibility for employment of Persons performing services under this CONTRACT.

B. Security and Background Investigations

Security and background investigations of CONTRACTOR's staff may be required at the discretion of COUNTY as a condition of beginning and continuing work under any resulting CONTRACT. The cost of background checks is the responsibility of CONTRACTOR.

C. Consideration of Hiring COUNTY Employees

Should CONTRACTOR require additional or replacement personnel after the effective date of this CONTRACT to perform the services set forth herein, CONTRACTOR shall give first consideration for such employment openings to qualified permanent COUNTY employees who are targeted for layoff or qualified, former COUNTY employees who are on a reemployment list during the life of this CONTRACT.

D. Conflict of Interest

No COUNTY employee whose position with COUNTY enables such employee to influence the award of this CONTRACT or any competing contract, and no spouse or economic dependent of such employee shall be employed in any capacity by CONTRACTOR or have any other direct or indirect financial interest in this

CONTRACT. No officer or employee of CONTRACTOR who may financially benefit from the performance of the work hereunder shall in any way participate in COUNTY's approval, or ongoing evaluation, of such work, or in any way attempt to unlawfully influence COUNTY's approval or ongoing evaluation of such work.

CONTRACTOR represents and warrants that it is aware of, and its authorized officers have read, the provisions of County Code, Section 2.180.010, "Certain Contracts Prohibited," and that execution of this CONTRACT will not violate those provisions. CONTRACTOR shall comply with all conflict of interest laws, ordinances, and regulations now in effect or hereafter to be enacted during the Term of this CONTRACT. CONTRACTOR warrants that it is not now aware of any facts that create a conflict of interest. If CONTRACTOR hereafter becomes aware of any facts that might reasonably be expected to create a conflict of interest, it shall immediately make full written disclosure of such facts to COUNTY. Full written disclosure shall include, but is not limited to, identification of all Persons implicated and a complete description of all relevant circumstances. Failure to comply with the provisions of this paragraph shall be a material breach of this CONTRACT subjecting CONTRACTOR to either contract termination for default or debarment proceedings or both. CONTRACTOR must sign and adhere to the "Conflict of Interest Certification" (Form PW-5).

E. Fair Labor Standards Act

CONTRACTOR shall comply with all applicable provisions of the Federal Fair Labor Standards Act and shall Indemnify, defend, and hold harmless COUNTY, its Special Districts, Elected Officials, Officers, Agents, Employees, and Volunteers from all liability, including, but not limited to, wages, overtime pay, liquidated damages, penalties, court costs, and attorneys' fees arising under any wage and hour law, including the Federal Fair Labor Standards Act, for work performed by CONTRACTOR's employees for which COUNTY may be found jointly or solely liable.

F. Consideration of Hiring GAIN and GROW Participants

- a. Should CONTRACTOR require additional or replacement personnel after the effective date of this Contract, CONTRACTOR shall give consideration for any such employment openings to participants in COUNTY's Department of Public Social Services Greater Avenues for Independence (GAIN) Program and General Relief Opportunity for Work (GROW) Program who meet CONTRACTOR's minimum qualifications for the open position. For this purpose, consideration shall mean that CONTRACTOR will interview qualified candidates. COUNTY will refer GAIN and GROW participants by category to CONTRACTOR. CONTRACTORS shall report all job openings with job requirements to: GAINGROW@dpss.lacounty.gov and BSERVICES@wdacs.lacounty.gov and DPSS will refer qualified GAIN/GROW job candidates.

- b. In the event that both laid-off COUNTY employees and GAIN and GROW participants are available for hiring, COUNTY employees shall be given first priority.

G. Record Retention and Inspection/Audit Settlement

CONTRACTOR shall maintain accurate and complete financial Records of its activities and operations relating to this CONTRACT in accordance with generally accepted accounting principles. CONTRACTOR shall also maintain accurate and complete employment and other Records relating to its performance of this CONTRACT. CONTRACTOR agrees that COUNTY, or its authorized representatives, shall have access to and the right to examine, audit, review Records, excerpt, copy, or transcribe any pertinent transaction, activity, or record relating to this CONTRACT. All such material, including, but not limited to, all financial Records, bank statements, cancelled checks, or other proof of payment, timecards, sign-in/sign-out sheets, and other time and employment Records, and proprietary data and information, shall be kept and maintained by CONTRACTOR and shall be made available to COUNTY during the Term of this CONTRACT and for a period of five years thereafter unless COUNTY's written permission is given to Dispose of any such material prior to such time. All such material shall be maintained by CONTRACTOR at a location in COUNTY, provided that if any such material is located outside COUNTY, then, at COUNTY's option, CONTRACTOR shall pay COUNTY for travel, per diem, and other costs incurred by COUNTY to examine, audit, review Records, excerpt, copy, or transcribe such material at such other location.

1. If a review of Records of CONTRACTOR is conducted specifically regarding this CONTRACT by any Federal or State auditor, or by any auditor, reviewer, or accountant employed by CONTRACTOR or otherwise, then CONTRACTOR shall file a copy of such review of Records Report with COUNTY's Auditor-Controller within 30 days of CONTRACTOR's receipt thereof, unless otherwise provided by applicable Federal or State law or under this CONTRACT. Subject to applicable law, COUNTY shall make a reasonable effort to maintain the confidentiality of such review of Records Report (s).
2. Failure on the part of CONTRACTOR to comply with any of the provisions of this paragraph shall constitute a material breach of this CONTRACT upon which COUNTY may suspend or terminate for default or suspend this CONTRACT.
3. If, at any time during the Term of this CONTRACT or within five years after the expiration or termination of this CONTRACT, representatives of COUNTY conduct a review of Records of CONTRACTOR regarding the work performed under this CONTRACT, and if such review of Records finds that COUNTY's dollar liability for any such work is less than payments made by COUNTY to CONTRACTOR, then the difference shall be either: a) repaid

by CONTRACTOR to COUNTY by cash payment upon demand or b) at the sole option of COUNTY's Auditor-Controller, deducted from any amounts due to CONTRACTOR from COUNTY, whether under this CONTRACT or otherwise. If such review of Records finds that COUNTY's dollar liability for such work is more than the payments made by COUNTY to CONTRACTOR, then the difference shall be paid to CONTRACTOR by COUNTY by cash payment, provided that in no event shall COUNTY's maximum obligation for this CONTRACT exceed the funds appropriated by COUNTY for this CONTRACT.

H. Compliance with COUNTY's Jury Service Program

1. Jury Service Program

This CONTRACT is subject to the provisions of COUNTY's ordinance entitled CONTRACTOR Employee Jury Service (Jury Service Program) as codified in Sections 2.203.010 through 2.203.090 of County Code.

2. Written Employee Jury Service Policy

- a. Unless CONTRACTOR has demonstrated to COUNTY's satisfaction either that CONTRACTOR is not a "CONTRACTOR" as defined under the Jury Service Program (Section 2.203.020 of County Code) or that CONTRACTOR qualifies for an exception to the Jury Service Program (Section 2.203.070 of County Code), CONTRACTOR shall have and adhere to a written policy that provides that its Employees shall receive from CONTRACTOR, on an annual basis, no less than five days of regular pay for actual jury service. The policy may provide that Employee deposit any fees received for such jury service with CONTRACTOR or that CONTRACTOR deduct from the Employee's regular pay the fees received for jury service.
- b. For purposes of this Section, "CONTRACTOR" means a Person, partnership, corporation, or other entity which has a contract with COUNTY or a subcontract with a COUNTY contractor and has received or will receive an aggregate sum of \$50,000 or more in any 12-month period under one or more COUNTY contracts or subcontracts. "Employee" means any California resident who is a full-time employee of CONTRACTOR. "Full-time" means 40 hours or more worked per week, or a lesser number of hours if: 1) the lesser number is a recognized industry standard as determined by COUNTY, or 2) CONTRACTOR has a long-standing practice that defines the lesser number of hours as full-time. Full-time employees providing short-term, temporary services of 90 days or less within a 12-month period are not considered full-time for purposes of the Jury Service Program. If CONTRACTOR uses any Subcontractor to perform services for COUNTY under this CONTRACT, the

Subcontractor shall also be subject to the provisions of this Section. The provisions of this Section shall be inserted into any such subcontract CONTRACT and a copy of the Jury Service Program shall be attached to the CONTRACT.

- c. If CONTRACTOR is not required to comply with the Jury Service Program when this CONTRACT commences, CONTRACTOR shall have a continuing obligation to review the applicability of its "exception status" from the Jury Service Program, and CONTRACTOR shall immediately notify COUNTY if CONTRACTOR at any time either comes within the Jury Service Program's definition of "CONTRACTOR" or if CONTRACTOR no longer qualifies for an exception to the Jury Service Program. In either event, CONTRACTOR shall immediately implement a written policy consistent with the Jury Service Program. COUNTY may also require, at any time during this CONTRACT and at its sole discretion, that CONTRACTOR demonstrate to COUNTY's satisfaction that CONTRACTOR either continues to remain outside of the Jury Service Program's definition of "CONTRACTOR" and/or that CONTRACTOR continues to qualify for an exception to the Jury Service Program.
- d. CONTRACTOR's violation of this Section of this CONTRACT may constitute a material breach of this CONTRACT. In the event of such material breach, COUNTY may, in its sole discretion, suspend or terminate this CONTRACT and/or bar CONTRACTOR from the award of future COUNTY contracts for a period consistent with the seriousness of the breach.

I. CONTRACTOR's Charitable Activities Compliance

The Supervision of Trustees and Fundraisers for Charitable Purposes Act regulates entities receiving or raising charitable contributions. The "Nonprofit Integrity Act of 2004" (SB 1262, Chapter 919) increased Charitable Purposes Act requirements. By requiring CONTRACTOR's to complete the Charitable Contributions Certification (Form PW-12), COUNTY seeks to ensure that all COUNTY CONTRACTOR's which receive or raise charitable contributions comply with California law to protect COUNTY and its taxpayers. A CONTRACTOR which receives or raises charitable contributions without complying with its obligations under California law commits a material breach subjecting it to either contract termination for default or debarment proceedings or both. (County Code Chapter 2.202)

J. Social Enterprise Preference Program

This CONTRACT is subject to the provisions of COUNTY's ordinance entitled Social Enterprise (SE) Preference Program, as codified in Chapter 2.205 of County Code.

CONTRACTOR shall not knowingly and with the intent to defraud, fraudulently obtain, retain, attempt to obtain or retain, or aid another in fraudulently obtaining or retaining or attempting to obtain or retain certification as a SE.

CONTRACTOR shall not willfully and knowingly make a false statement with the intent to defraud, whether by affidavit, Report, or other representation, to a COUNTY official or employee for the purpose of influencing the certification or denial of certification of any entity as a SE.

If CONTRACTOR has obtained COUNTY certification as a SE by reason of having furnished incorrect supporting information or by reason of having withheld information, and which knew, or should have known, the information furnished was incorrect or the information withheld was relevant to its request for certification, and which by reason of such certification has been awarded this contract to which it would not otherwise have been entitled, CONTRACTOR shall:

- Pay to COUNTY any difference between the CONTRACT amount and what COUNTY's costs would have been if the CONTRACT had been properly awarded.
- In addition to the amount described in subdivision (1), be assessed a penalty in the amount of not more than ten percent of the amount of this Contract.
- Be subject to the provisions of Chapter 2.202 of County Code (Determinations of CONTRACTOR Nonresponsibility and CONTRACTOR Debarment).

The above penalties shall also apply to any entity that has previously obtained proper certification, however, as a result of a change in their status would no longer be eligible for certification and fails to notify the Department of Consumer and Business Affairs of this information prior to responding to a solicitation or accepting a contract award.

K. Local Small Business Enterprise Preference Program

This CONTRACT is subject to the provisions of COUNTY's ordinance entitled Local Small Business Enterprise Preference Program, as codified in Chapter 2.204 of County Code.

CONTRACTOR shall not knowingly and with the intent to defraud, fraudulently obtain, retain, attempt to obtain or retain, or aid another in fraudulently obtaining or retaining or attempting to obtain or retain certification as a Local Small Business Enterprise.

CONTRACTOR shall not willfully and knowingly make a false statement with the intent to defraud, whether by affidavit, Report, or other representation, to a COUNTY official or employee for the purpose of influencing the certification or denial of certification of any entity as a Local Small Business Enterprise.

If CONTRACTOR has obtained COUNTY certification as a Local Small Business Enterprise by reason of having furnished incorrect supporting information or by reason of having withheld information, and which knew, or should have known, the information furnished was incorrect or the information withheld was relevant to its request for certification, and which by reason of such certification has been awarded this CONTRACT to which it would not otherwise have been entitled, shall:

- Pay to COUNTY any difference between this CONTRACT amount and what COUNTY's costs would have been if this CONTRACT had been properly awarded.
- In addition to the amount described in subdivision (1), be assessed a penalty in an amount of not more than ten percent of the amount of this CONTRACT.
- Be subject to the provisions of Chapter 2.202 of County Code (Determinations of CONTRACTOR Nonresponsibility and CONTRACTOR Debarment).

The above penalties shall also apply to any business that has previously obtained proper certification, however, as a result of a change in their status would no longer be eligible for certification and fails to notify the State and the Department of Consumer and Business Affairs of this information prior to responding to a solicitation or accepting a contract award.

L. Disabled Veteran Enterprise Preference Program

This CONTRACT is subject to the provisions of COUNTY's ordinance entitled Disabled Veteran Business Enterprise (DVBE) Preference Program, as codified in Chapter 2.211 of County Code.

CONTRACTOR shall not knowingly and with the intent to defraud, fraudulently obtain, retain, attempt to obtain or retain, or aid another in fraudulently obtaining or retaining or attempting to obtain or retain certification as a DVBE.

CONTRACTOR shall not willfully and knowingly make a false statement with the intent to defraud, whether by affidavit, Report, or other representation, to a COUNTY official or employee for the purpose of influencing the certification or denial of certification of any entity as a DVBE.

If CONTRACTOR has obtained certification as a DVBE by reason of having furnished incorrect supporting information or by reason of having withheld information, and which knew, or should have known, the information furnished was incorrect or the information withheld was relevant to its request for certification, and which by reason of such certification has been awarded this contract to which it would not otherwise have been entitled, shall:

- Pay to COUNTY any difference between the CONTRACT amount and what COUNTY's costs would have been if the CONTRACT had been properly awarded.
- In addition to the amount described in subdivision (1), be assessed a penalty in an amount of not more than ten percent of the amount of the CONTRACT.
- Be subject to the provisions of Chapter 2.202 of County Code (Determinations of CONTRACTOR Nonresponsibility and CONTRACTOR Debarment).

Notwithstanding any other remedies in this contract, the above penalties shall also apply to any business that has previously obtained proper certification, however, as a result of a change in their status would no longer be eligible for certification and fails to notify the State and the Department of Consumer and Business Affairs of this information prior to responding to a solicitation or accepting a contract award.

M. CONTRACTOR Responsibility and Debarment

1. Responsible CONTRACTOR

A responsible CONTRACTOR is a contractor who has demonstrated the attribute of trustworthiness as well as quality, conditions, capacity, and experience to satisfactorily perform the CONTRACT. It is COUNTY's policy to conduct business only with responsible contractors.

2. Chapter 2.202 of County Code

CONTRACTOR is hereby notified that, in accordance with Chapter 2.202 of County Code, if COUNTY acquires information concerning the performance of CONTRACTOR on this or other contracts which indicates that CONTRACTOR is not responsible, COUNTY may, in addition to other remedies provided in this CONTRACT, debar CONTRACTOR from bidding or proposing on, being awarded, and/or performing work on COUNTY contracts for a specified period of time, which generally will not exceed 5 years but may exceed 5 years or be permanent if warranted by the circumstances, and suspend or terminate any or all existing contracts CONTRACTOR may have with COUNTY.

3. Nonresponsible CONTRACTOR

COUNTY may debar a CONTRACTOR if the Board finds, in its discretion, that CONTRACTOR has done any of the following: (1) violated any Term of a contract with COUNTY or a nonprofit corporation created by COUNTY; (2) committed an act or omission which negatively reflects on CONTRACTOR's quality, condition, or capacity to perform a contract with

COUNTY, any other public entity, or a nonprofit corporation created by COUNTY, or engaged in a pattern or practice which negatively reflects on same; (3) committed an act or offense which indicates a lack of business integrity or business honesty; or (4) made or submitted a false claim against COUNTY or any other public entity.

4. Contractor Hearing Board

- a. If there is evidence that CONTRACTOR may be subject to debarment, Public Works will notify CONTRACTOR in writing of the evidence which is the basis for the proposed debarment and will advise CONTRACTOR of the scheduled date for a debarment hearing before Contractor Hearing Board.
- b. Contractor Hearing Board will conduct a hearing where evidence on the proposed debarment is presented. CONTRACTOR and/or CONTRACTOR's representative shall be given an opportunity to submit evidence at that hearing. After the hearing, Contractor Hearing Board will prepare a tentative proposed decision, which shall contain a recommendation regarding whether CONTRACTOR should be debarred, and, if so, the appropriate length of time of the debarment. CONTRACTOR and Public Works shall be provided an opportunity to object to the tentative proposed decision prior to its presentation to the Board of Supervisors.
- c. After consideration of any objections, or if no objections are submitted, a record of the hearing, the proposed decision, and any other recommendation of Contractor Hearing Board shall be presented to the Board. The Board of Supervisors shall have the right to modify, deny, or adopt the proposed decision and recommendation of Contractor Hearing Board.
- d. If a CONTRACTOR has been debarred for a period longer than five years, that CONTRACTOR may, after the debarment has been in effect for at least five years, submit a written request for review of the debarment determination to reduce the period of debarment or terminate the debarment. COUNTY may, in its discretion, reduce the period of debarment or terminate the debarment if it finds that CONTRACTOR has adequately demonstrated one or more of the following: (1) elimination of the grounds for which the debarment was imposed; (2) a bona fide change in ownership or management; (3) material evidence discovered after debarment was imposed; or (4) any other reason that is in the best interests of COUNTY.
- e. Contractor Hearing Board will consider a request for review of a debarment determination only where (1) CONTRACTOR has been debarred for a period longer than five years; (2) the debarment has

been in effect for at least five years; and (3) the request is in writing, states one or more of the grounds for reduction of the debarment period or termination of the debarment, and includes supporting documentation. Upon receiving an appropriate request, Contractor Hearing Board will provide Notice of the hearing on the request. At the hearing, Contractor Hearing Board shall conduct a hearing where evidence on the proposed reduction of debarment period or termination of debarment is presented. This hearing shall be conducted and the request for review decided by Contractor Hearing Board pursuant to the same procedure as for a debarment hearing.

- f. Contractor Hearing Board's proposed decision shall contain a recommendation on the request to reduce the period of debarment or terminate the debarment. Contractor Hearing Board shall present its proposed decision and recommendation to the Board of Supervisors. The Board of Supervisors shall have the right to modify, deny, or adopt the proposed decision and recommendation of Contractor Hearing Board.

5. Subcontractors of CONTRACTOR

These terms shall also apply to Subcontractors of COUNTY CONTRACTORS.

N. Reporting Requirements for Improper Solicitations

CONTRACTOR shall immediately report any attempt by a COUNTY officer or employee to solicit improper consideration. CONTRACTOR shall make the Report either to COUNTY manager charged with the supervision of the employee or to COUNTY Fraud Hotline at (800) 544-6861 or www.lacountyfraud.org. Among other items, improper consideration may take the form of cash; discounts; service; or the provision of travel, entertainment, or tangible gifts.

O. COUNTY's Quality Assurance Plan

COUNTY or its agent will monitor CONTRACTOR's performance under this CONTRACT on not less than an annual basis. Such monitoring will include assessing CONTRACTOR's compliance with all this CONTRACT's terms and conditions and performance Standards. CONTRACTOR deficiencies which COUNTY determines are significant or continuing and that may place performance of this CONTRACT in jeopardy, if not corrected, will be reported to the Board. The Report will include improvement/corrective action measures taken by COUNTY and CONTRACTOR.

If improvement does not occur consistent with the corrective action measures, COUNTY may suspend or terminate this CONTRACT for default or impose other penalties as specified in this CONTRACT.

P. Local Small Business Enterprise Utilization

When requested by COUNTY, CONTRACTOR shall provide to COUNTY via methods specified by COUNTY, such as submission of electronic live (or dynamic) data on invoices for the prime and all Subcontractors using COUNTY-designated third-Party software system or to a COUNTY approved website, or other means of submitting expenditure information on Subcontractors, including but not limited to the following information: the name, business address and telephone number/e-mail address of each Subcontractor.

In addition, CONTRACTOR shall be required to provide each of the specified Subcontractor Local Small Business Enterprise (SBE), Disabled Veteran Business Enterprise (DVBE), and Social Enterprise (SE) status (i.e., whether any of the listed Subcontractors are Local SBE's) and the proposed monetary amount of the work the Subcontractor will perform on each Notice to Proceed. At the time of submittal of each invoice, CONTRACTOR shall indicate, via methods specified by COUNTY, the actual dollar amounts paid to each listed Subcontractor who performed work on the project. The Subcontractor may be requested to confirm receipt of the actual payment to the Subcontractor by the prime.

The Parties agree that it will be impracticable or extremely difficult to fix the extent of actual damages resulting from the failure to CONTRACTOR to comply with this Section. The Parties will agree that under the current circumstances a reasonable estimate of such damages is specified in Exhibit F, Performance Requirements Summary, and that CONTRACTOR shall be liable to COUNTY for said amount.

If in the judgment of Director, or his/her designee, CONTRACTOR is deemed to be in non-compliance with the terms and obligations, Director or his/her designee, at his/her option, in addition to, or in lieu of, other remedies provided in Exhibit F, Performance Requirements Summary, may deduct and withhold liquidated damages from COUNTY's final payment to CONTRACTOR.

Q. Compliance with COUNTY's Zero Tolerance Human Trafficking

CONTRACTOR acknowledges that COUNTY has established a Zero Tolerance Human Trafficking Policy prohibiting contractors from engaging in human trafficking.

If a CONTRACTOR or member of CONTRACTOR's staff is convicted of a human trafficking offense, COUNTY shall require that CONTRACTOR or member of CONTRACTOR's staff be removed immediately from performing services under the CONTRACT. COUNTY will not be under any obligation to disclose confidential information regarding the offenses other than those required by law.

Disqualification of any member of CONTRACTOR's staff pursuant to this paragraph shall not relieve CONTRACTOR of its obligation to complete all work in accordance with the terms and conditions of this CONTRACT.

R. Method of Payment and Required Information

The County may, at its sole discretion, determine the most appropriate, efficient, secure, and timely form of payment for any amounts due for goods and/or services provided under a Contract with the County. Proposers/Contractors further agree that the default form of payment shall be EFT or direct deposit, unless an alternative method of payment is deemed appropriate by the A-C.

Upon Contract award and at the request of the A-C and/or Public Works, the Contractor shall provide the A-C with electronic banking and related information for the Contractor and/or any other payee that the Contractor designates to receive payment pursuant to this Contract. Such electronic banking and related information includes, but is not limited to: bank account number and routing number, legal business name, valid taxpayer identification number or TIN, a working e-mail address capable of receiving remittance advices and other payment related correspondence, and any other information that the A-C determines is reasonably necessary to process the payment and comply with all accounting, recordkeeping, and tax reporting requirements.

Any provision of law, grant, or funding agreement requiring a specific form or method of payment other than EFT or direct deposit shall supersede this requirement with respect to those payments. Upon Contract award or at any time during the duration of the Contract, a Contractor may submit a written request for an exemption to this requirement. Such request must be based on specific legal, business or operational needs and explain why the payment method designated by the A-C is not feasible and an alternative is necessary. The A-C, in consultation with Public Works, shall decide whether to approve exemption requests.

S. Compliance with Fair Chance Employment Practices

Contractor shall comply with fair chance employment hiring practices set forth in California Government Code Section 12952, Employment Discrimination: Conviction History. Contractor's violation of this paragraph of the Contract may constitute a material breach of the Contract. In the event of such material breach, County may, in its sole discretion, terminate the Contract.

T. Compliance with the County Policy of Equity

The Contractor acknowledges that the County takes its commitment to preserving the dignity and professionalism of the workplace very seriously, as set forth in the County Policy of Equity (CPOE) (<https://ceop.lacounty.gov/>). The contractor further acknowledges that the County strives to provide a workplace free from

discrimination, harassment, retaliation and inappropriate conduct based on a protected characteristic, and which may violate the CPOE. The Contractor, its employees and Subcontractors acknowledge and certify receipt and understanding of the CPOE. Failure of the Contractor, its employees or its Subcontractors to uphold the County's expectations of a workplace free from harassment and discrimination, including inappropriate conduct based on a protected characteristic, may subject the Contractor to termination of contractual agreements as well as civil liability.

U. Contractor Independence

A Contractor or its subsidiary or Subcontractor (Contractor), is prohibited from submitting a bid or proposal in a County solicitation if the Contractor has provided advice or consultation for the solicitation. A Contractor is also prohibited from submitting a bid or proposal in a County solicitation if the Contractor has developed or prepared any of the solicitation materials on behalf of the County. A violation of this provision shall result in the disqualification of the Contractor from participation in the County solicitation or the termination or cancellation of any resultant County contract. This provision shall survive the expiration, or other termination of this CONTRACT.

V. Contractor Alert Reporting Database (CARD)

The County maintains databases that track/monitor Contractor performance history. Information entered into such databases may be used for a variety of purposes, including determining whether the County will exercise a contract term extension option.

W. Federally Funded Work

This provision will apply when federally funded or potentially federally funded work is needed by County. In accordance with Federal Executive Order 12549 and 12689 (Debarment and Suspension), individuals or entities that have been debarred by the Federal government may not receive work under this Contract as a Contractor or Subcontractor. Contractors and/or Subcontractors listed on the governmental exclusions in the System for Award Management (SAM) are not eligible to receive federally funded work under this contract. See Office of Management and Budget guidelines at 2 CFR 180 that implement Executive Orders 12549 (3 CFR part 1986 Comp., p. 189) and 12689 (3 CFR part 1989 Comp., p. 235), "Debarment and Suspension". The System for Award Management exclusions contains the names of parties debarred, suspended, or otherwise excluded by Federal agencies as well as parties declared ineligible under statutory or regulatory authority.

For federally funded work, the Contract Manager will, before assigning work to the Contractor, verify that the Contractor is not listed on the governmental exclusions in the System for Award Management (SAM) as a party excluded or ineligible by

Federal agencies to participate in federally funded projects. For your reference, a List of Debarred Contractors by U.S. Department of Labor's (DOL) Office of Federal Contract Compliance Programs (OFCCP) may be obtained by going to the following website: <https://www.sam.gov/portal/SAM/>.

If the Contractor is listed on the governmental exclusions in the System for Award Management (SAM) as a party excluded or ineligible by Federal agencies to participate in federally funded projects, then said Contractor will not be offered the work. The Contract Manager will notify the Contractor of their negative standing in the SAM. The Contract Manager will also notify the Contractor of their ineligibility to receive any federally funded work under this contract, until the Contractor is able to satisfactorily correct the issue. The Contractor shall notify the Contract Manager when the Contractor has corrected their negative standing in the SAM, and the Contractor is no longer listed on the governmental exclusions in the SAM.

If the Contractor is **not** listed on the governmental exclusions in the System for Award Management (SAM) as a party excluded or ineligible by Federal agencies to participate in federally funded projects, Public Works may offer said Contractor the federally funded work.

The Contractor is required to verify that its subcontractors are not listed on the governmental exclusions in the System for Award Management (SAM), before assigning federally funded work to its subcontractors.

PART 2 - INDEMNIFICATION AND INSURANCE

A. Indemnification and Release of COUNTY

CONTRACTOR shall release, Indemnify, defend, and hold harmless COUNTY and County's Related Parties from and against all Liabilities arising from, connected with, or relating to all the following:

1. Operations

CONTRACTOR and Contractor's Related Parties' operations or any of their respective services on or after the date of this CONTRACT, including the Contract Services and Liabilities further detailed in the following Indemnifications contained in Part 2A2 through Part 2A5 of this Exhibit 5, but excluding any Liabilities arising from the sole active negligence or willful misconduct of COUNTY.

2. Cal/OSHA

Without limiting the operations Indemnification in Part 2A1 of Exhibit 5, employer sanctions and any other Liabilities that may be assessed against CONTRACTOR or COUNTY or both about any alleged act or omission of CONTRACTOR or any of Contractor's Related Parties that is in violation of any Cal/OSHA regulation. This obligation includes all investigations and proceedings associated with purported violations of 8 CCR 336.10 pertaining to multiemployer work sites. CONTRACTOR shall not be obligated to so release, Indemnify, defend, and hold harmless COUNTY from and against any Liabilities arising from the sole active negligence or willful misconduct of COUNTY.

3. Immigration

Without limiting the operations Indemnification in Part 2A1 of Exhibit 5, employer sanctions and any other Liabilities that may be assessed against CONTRACTOR, any of Contractor's Related Parties or COUNTY or any one or all of them about any alleged violation of Federal Applicable Law (including the Immigration Reform and Control Act of 1986 (PL. 99-603) pertaining to the eligibility for employment of individuals performing Contract Services. CONTRACTOR shall not be obligated to so Indemnify, release, defend, and hold harmless COUNTY from and against any Liabilities arising from the sole active negligence or willful misconduct of COUNTY.

4. Enforcement of CONTRACT or Applicable Law

Without limiting the operations Indemnification in Part 2A1 of Exhibit 5, any Liabilities that may be assessed against CONTRACTOR, any of Contractor's Related Parties or COUNTY or any one or all of them about any alleged failure of COUNTY to exercise COUNTY's rights under this CONTRACT or

to enforce provisions of this CONTRACT or of Applicable Law as permitted under Part 7A4 of Exhibit 5, except for any Liabilities arising from the sole active negligence or willful misconduct of COUNTY.

5. Disposal

The presence, Disposal, placement, migration, leakage, spillage, discharge, release, or emission of Unpermitted Waste, petroleum or any other Solid Waste to, in, on, at, or under any Vehicle, place, site, or facility where CONTRACTOR or any of Contractor's Related Parties transports, delivers, stores, processes, Recycles, Composts or Disposes of Solid Waste to the extent that Liabilities are caused indirectly or directly by any of the following:

a. CONTRACTOR Negligence or Misconduct

The wrongful, willful, or negligent act, error or omission, or the misconduct of CONTRACTOR or any of Contractor's Related Parties; wrongful, willful, or negligent act, error, omission, or misconduct includes but is not limited to the Disposal, placement, leakage, spillage, discharge, release, or emission of Unpermitted Waste, petroleum or any other Solid Waste onto a place not designated or approved for Disposal or Processing of said Unpermitted Waste, petroleum, or Solid Waste.

b. Non-Customer Materials

The Collection, delivery, handling, Recycling, Processing, Composting or Disposal by CONTRACTOR or any of Contractor's Related Parties of any materials or waste, including Unpermitted Waste, that are generated by Persons other than Customers and Occupants or Collected from Premises other than Premises;

c. Failure to Comply with Unpermitted Waste Screening Protocol

The failure of CONTRACTOR or any of Contractor's Related Parties to undertake Unpermitted Waste training procedures required by Applicable Law or the Unpermitted Waste Screening Protocol, whichever is more stringent; or

d. CONTRACTOR-Identified Unpermitted Waste

The improper or negligent Collection, handling, delivery, Processing, Recycling, Composting, or Disposal by CONTRACTOR or any of Contractor's Related Parties of Unpermitted Waste that CONTRACTOR or any of Contractor's Related Parties inadvertently Collects from Customers and Occupants and that CONTRACTOR or

any of Contractor's Related Parties identifies as Unpermitted Waste before its delivery, Processing, Recycling, Composting, or Disposal whether:

- (1) In one or more occurrence;
- (2) Threatened or transpired;
- (3) CONTRACTOR or any of Contractor's Related Parties is negligent or otherwise culpable; or
- (4) Those Liabilities are litigated, settled, or reduced to judgment.

For purposes of this item A5, "Liabilities" includes Liabilities arising from or attributable to any operations, repair, cleanup, or detoxification, or preparation and implementation of any removal, remedial, response, closure, post-closure, or other plan, regardless of whether undertaken due to government directive or action, such as remediation of surface or ground water contamination and replacement or restoration of natural resources.

The foregoing Indemnification under this item A5 is intended to operate as a CONTRACT under 42 U.S.C. Section 9607(e) and California Health and Safety Code Section 25364, to insure, protect, hold harmless, and Indemnify COUNTY from liability in accordance with this Section.

The mere presence of household hazardous waste in the Solid Waste that is Collected by CONTRACTOR or any of Contractor's Related Parties under this CONTRACT will not constitute negligence and in and of itself create any liability on the part of CONTRACTOR or any of Contractor's Related Parties absent any of the circumstances described in items a through d in this item A5.

With respect to COUNTY's defense under this item A5, COUNTY reserves the right to retain co-counsel at its own cost and expense and CONTRACTOR shall direct CONTRACTOR's counsel to assist and cooperate with COUNTY'S co-counsel.

CONTRACTOR hereby releases and shall not seek contribution or compensation of any nature from COUNTY for Liabilities relating to Unpermitted Waste, including relating to RCRA, CERCLA, or the California Health and Safety Code. CONTRACTOR shall not make any claims against or assert an interest in any account, fund, or reserve that COUNTY may establish or set aside from the proceeds of the Franchise Fee or otherwise or maintains to cover Liabilities relating to Unpermitted Waste, which established fund or reserve COUNTY is under no obligation to establish or maintain.

B. Insurance

Without limiting its Indemnities, and in the performance of this CONTRACT and until all its Performance Obligations pursuant to this CONTRACT have been met, CONTRACTOR shall provide and maintain the following programs of insurance at its own expense. Performance Obligations under this Section are in addition to and separate from any other Performance Obligation in this CONTRACT. COUNTY reserves the right to review and adjust the insurance requirements in this Section if COUNTY determines that there have been changes in risk exposures. COUNTY makes no warranty that the insurance coverage terms, types, and limits in this Part 2B is sufficient to protect CONTRACTOR for Liabilities that may arise from or in relation to this CONTRACT.

1. Primary, Excess, Non-Contributory

All CONTRACTOR's insurance carried under this Part 2B shall be primary with respect to any other insurance or self-insurance programs available to COUNTY.

2. Cancellation Notices

All insurance shall contain the express condition that COUNTY is to be given written Notice by mail at least 30 days in advance of cancellation, or at least ten days in advance of cancellation for nonpayment of premium, for all policies evidenced on the certificate of insurance.

3. Noncompliance

Neither COUNTY'S failure to obtain, nor COUNTY'S receipt of, or failure to object to a noncomplying insurance certificate or endorsement or any other insurance documentation or information provided by CONTRACTOR, its insurance broker(s) and/or insurer(s), shall be construed as a waiver of any Performance Obligation under this Part 2B. If CONTRACTOR does not provide and maintain those programs of insurance, COUNTY may purchase required insurance coverage without further Notice to CONTRACTOR, and COUNTY may charge CONTRACTOR any premium costs advanced by COUNTY for that insurance and draw on the Performance Assurance provided by CONTRACTOR.

4. Evidence of Insurance: COIs and copies of policies

At least 30 days prior to the Execution Date and thereafter no less than 10 days prior to each policy renewal and within two business days of any Director request, CONTRACTOR shall deliver a certificate or certificates of insurance or other evidence of coverage acceptable to Director at the address provided for Notices. Certificates or other evidence must:

a. Specifically identify this CONTRACT by name or number

name the insured Party that matches the name of CONTRACTOR executing this CONTRACT; provide the full name of each insurer providing coverage and the insurer's NAIC (National Association of Insurance Commissioners) identification number, and financial rating.

b. Types and limits

Clearly evidence all coverage, types, and limits required in this CONTRACT. Identify standard policy forms or their equivalent. Coverage may consist of a combination of primary and excess policies. Excess policies must provide coverage as broad as ("follow form" over) the underlying primary policies;

c. Cancellation Notice

Contain the express condition that Director is to be given written Notice by mail at least 30 days in advance of cancellation (ten days for nonpayment of premium) for all policies evidenced on the certificate of insurance;

d. List additional endorsements

(1) Additional insured endorsements. Include copies of the additional insured endorsements to General Liability Policy which must add COUNTY and its Special Districts, elected officials, officers, agents, and employees as additional insureds with respect to liability arising out of ongoing and completed Contract Services, and applicable with respect to liability and defense of suits arising out of CONTRACTOR's acts or omissions, whether that liability is attributable to CONTRACTOR or COUNTY. The full policy limits and scope of protection must apply to each of those additional insureds even if those limits or scope exceed the minimum required insurance specifications in this CONTRACT. CONTRACTOR may use an automatic additional insured endorsement if the endorsements meet the requirements of this Part 2B.

(2) Waiver of Subrogation Endorsements. Include copies of subrogation endorsements necessary to effect CONTRACTOR's waiver of its and its insurer(s)' rights of recovery against COUNTY under all insurance under Part 2B, to the fullest extent permitted by law.

e. Deductibles and SIRs

Identify any deductibles or self-insured retention ("SIR") exceeding \$50,000 for Director's approval. CONTRACTOR's policies shall not

obligate COUNTY to pay any portion of any CONTRACTOR deductible or SIRCOUNTY retains the right to require CONTRACTOR to reduce any deductibles or self-insured retention as they apply to COUNTY or to require CONTRACTOR to provide a bond, letter of credit, or certificate of deposit guaranteeing payment of all retained losses and related costs, including expenses, or both, related to investigations, claims administrations, and defense. The bond must be executed by a corporate surety licensed to transact business in the State of California; the letter of credit must be issued by a bank or other financial institution acceptable to Director.

If CONTRACTOR has not reached its SIR maximum, CONTRACTOR shall defend COUNTY in the same manner that insurers would have defended COUNTY under required insurance policies.

f. Signature verification

Include documentation acceptable to Director verifying that the individual signing or countersigning the certificates, and at Director's request, the policies, endorsements, or other evidence of coverage, is authorized to do so and identifies his or her company affiliation and title.

g. Certified Copies of any Policy

COUNTY's request, CONTRACTOR shall Promptly provide COUNTY with complete, certified copies of any policy of insurance that CONTRACTOR must secure and maintain under this CONTRACT.

h. Claims Made/Retroactive Date

The policy retroactive date, which can be identified on any insurance written on claims made basis, which must precede the Execution Date. CONTRACTOR shall maintain any claims made coverage for a period of not less than 3 years following expiration, termination, or cancellation of this CONTRACT.

i. Insured-vs.-insured

Clearly evidence that all liability policies provide cross-liability coverage as would be afforded by the standard ISO (Insurance Services Office, Inc.) separation of insureds provision with no insured-versus-insured exclusions or limitations.

5. Insurer Financial Rating

CONTRACTOR shall secure insurance provided by an insurance company acceptable to COUNTY with a rating by A.M. Best Company of not less than A: VII, unless otherwise approved by COUNTY.

6. Notification of Incidents, Claims, or Suits

CONTRACTOR shall Promptly report the following in writing to Director:

- a. Any accident or incident relating to the Contract Services involving injury or property damage that may result in the filing of an insurance claim, its legal claim, or lawsuit against CONTRACTOR, any Subcontractor, and/or COUNTY;
- b. Any third-Party claim or lawsuit filed against CONTRACTOR arising from or related to Contract Services;
- c. Any injury to a CONTRACTOR employee that occurs on COUNTY property, or,
- d. Any loss, disappearance, destruction, misuse, or theft of COUNTY property, money, or securities entrusted to CONTRACTOR.

CONTRACTOR shall submit its Report on a COUNTY "Nonemployee Injury Report" form available on COUNTY's website at <http://cao.co.la.ca.us/RMB/pdf/NonEmployeeInjuryReport.pdf>.

7. Insurance Coverage Requirements.

CONTRACTOR shall secure and maintain insurance coverage meeting the following requirements:

- a. **General Liability Insurance** (written on ISO policy form CG 00 01 or its equivalent) with limits of not less than the following:

| | |
|--|-------------|
| General Annual Aggregate: | \$4 million |
| Products/Completed Operations Aggregate: | \$4 million |
| Personal and Advertising Injury: | \$1 million |
| Each Occurrence: | \$2 million |

The general liability policy must provide contractual liability coverage for CONTRACTOR's Indemnification of COUNTY.

- b. **Pollution Liability Coverage** for pollution conditions resulting from transported cargo, with annual limits of not less than \$2 million per occurrence and \$4 million aggregate, covering loss (including cleanup costs) that CONTRACTOR becomes legally obligated to pay as a result of claims for bodily injury, property damage, and cleanup costs

(including expenses required by environmental laws or incurred by Federal, State, or local governments or third Parties) resulting from pollution conditions caused by transported cargo (including waste). For the purpose of this Part 2B7b, "pollution conditions" includes the dispersal, discharge, release, or escape of any solid, liquid, gaseous, or thermal irritant or contaminant (such as smoke, vapors, soot, fumes, acids, alkalis, toxic chemicals, medical waste, and waste materials) into or upon land, any structure on land, the atmosphere, or any watercourse or body of water (including groundwater), provided the conditions are not naturally present in the environment in the amounts or concentrations discovered. The pollution liability coverage must provide contractual liability coverage, by endorsement, if necessary, for CONTRACTOR's Indemnification of COUNTY. CONTRACTOR's general liability policy may be endorsed to provide the required pollution liability coverage.

c. **Automobile Liability Coverage** (written on ISO policy forms CA 00 12 or CA 00 20 or their equivalent) with a limit of liability not less than \$2 million for each accident and endorsed to include pollution liability (written on form CA 99 48 or its equivalent). The insurance must cover all Vehicles used by CONTRACTOR pursuant to its operations and services and the terms of this CONTRACT. CONTRACTORS subject to Federal regulations also shall maintain any other coverage necessary to satisfy State or Federal financial responsibility requirements.

d. **Workers' Compensation and Employers' Liability** insurance providing workers' compensation benefits required by the California Labor Code or by any other State labor law, and for which CONTRACTOR is responsible. In all cases, this insurance must also include Employers' Liability coverage with limits of not less than the following:

| | | |
|-----|--------------------------|-------------|
| (1) | Each accident: | \$1 million |
| (2) | Disease - policy limit: | \$1 million |
| (3) | Disease - each employee: | \$1 million |

e. **Application of Excess Liability Coverage** CONTRACTORS may use a combination of primary, and excess insurance policies which provide coverage broad as ("follow from" over) the underlying primary policies, to satisfy the required insurance provisions.

8. **Insurance Coverage Requirements for Subcontractors**

CONTRACTOR shall ensure that all Subcontractors performing Contract Services under this CONTRACT secure and maintain the insurance coverage required in Part 2B1 through B7 by providing evidence that either:

- CONTRACTOR is maintaining the required insurance covering the activities of Subcontractors, or
- Subcontractors are maintaining the required insurance coverage.

CONTRACTOR shall provide COUNTY with any Subcontractor request to modify that insurance coverage and get COUNTY approval prior to modification.

C. Compensation for COUNTY Costs

If CONTRACTOR fails to comply with any Performance Obligations, including Indemnification, insurance, and performance assurance and that failure results in any costs to COUNTY, CONTRACTOR shall pay full compensation for all County's Reimbursement Costs.

D. Alternative Risk Financing Programs

COUNTY reserves the right to review and then approve CONTRACTOR's use of self-insurance, risk retention groups, risk purchasing groups, pooling arrangements, and captive insurance to satisfy Performance Obligations under this Part 4B. COUNTY and Persons named as additional insureds under Part 4B4d shall be designated as an Additional Covered Party under any approved program.

PART 3 - SUSPENSION; TERMINATION; DEBARMENT BREACHES AND DEFAULTS

A. Notice of Breach; CONTRACTOR Cure Notice

If Director determines that CONTRACTOR is in Breach, Director may give Notice to CONTRACTOR identifying and describing the Breach.

CONTRACTOR shall remedy the Breach within 30 days from the receipt of Notice unless Director determines that the public health and safety require a shorter period. CONTRACTOR shall remedy a Breach or with respect to the Child Support Compliance Program described in Part 7B of Exhibit 5, 90 days after Notice by the COUNTY's Child Support Services Department. Director will hold a conference with CONTRACTOR within 30 days of CONTRACTOR request. CONTRACTOR may request additional time to correct the Breach, but Director may accept or reject that request at its sole discretion.

B. Contractor Default. The following constitute Contractor Defaults

1. Fraud, Misrepresentation, or Breach of Warranties

CONTRACTOR committed any fraud or deceit or made any intentional misrepresentations in the procurement of this CONTRACT; commits, or attempts to commit, any fraud or deceit upon COUNTY after the Award Date of this CONTRACT; makes any material misrepresentations or breaches any warranties in this CONTRACT (including Attachment 5-8H); or includes any materially false or misleading statement, representation, or warranty in any Record or Report.

2. Insolvency or Bankruptcy

CONTRACTOR becomes insolvent or files a voluntary petition to declare bankruptcy; a receiver or trust is appointed for CONTRACTOR; or CONTRACTOR executes an assignment for the benefit of creditors. CONTRACTOR is deemed to be "insolvent" if it has ceased to pay its debts in the ordinary course of business or cannot pay its debts as they become due, whether CONTRACTOR has committed an act of bankruptcy and whether CONTRACTOR is insolvent within the meaning of the Federal bankruptcy law or not.

3. Failure to Provide Insurance, Bonds

CONTRACTOR does not provide or maintain in full force and effect all insurance and other assurances of its Performance Obligations, including as required under Part 2 of Exhibit 5 and Section 15, or provide evidence of insurance coverage acceptable to Director.

4. Material or Repeated Violation of Applicable Law

a. Any material Violation of Applicable Law

That is not cured to the satisfaction of Director or applicable Regulatory Agency within 30 days of the Notice, assessment, or determination of that Violation of Applicable Law; or

b. Any repeated Violation of Applicable Law

If CONTRACTOR is entitled to and does contest a Notice, assessment, or determination of Violation of Applicable Law by proceedings conducted in good faith, no Contractor Default will be deemed to have occurred until a final decision adverse to CONTRACTOR is entered.

5. Failure to Collect for Seven Days

Unless due to Uncontrollable Circumstances or otherwise approved by Director, CONTRACTOR fails to Collect from all Occupants with respect to Collection Services for seven consecutive calendar days.

6. Failure to Collect for More Than Seven Days

With respect to Collection Services, if due to Uncontrollable Circumstances, CONTRACTOR fails to Collect from all Occupants for a period of more than seven consecutive calendar days.

7. Payments to COUNTY

CONTRACTOR does not timely and fully make any required payment to COUNTY required under this CONTRACT (including payments such as damages or County's Reimbursement Costs):

a. More than twice in any Calendar Year;

b. Within 60 days of Notice by Director that payment is due; or

c. With respect to payment of a shortfall in the Franchise Fees, within 60 days of Notice in accordance with Section 9C.

8. Specified Contractor Defaults

CONTRACTOR Breaches any of the following Sections:

a. Part 7B of Exhibit 5 Child Support Compliance Program

(if not cured within 90 days of Notice given as described in Part 3 of Exhibit 5);

- b. Part 8C1 of Exhibit 5 Compliance with ILO Convention Concerning Minimum Age for Employment;*
- c. Part 8D of Exhibit 5 Nondiscrimination;*
- d. Part 8F of Exhibit 5 County Lobbyist Ordinance; or*
- e. Part 3F of Exhibit 5 Termination for Breach of Warranty to Maintain Compliance with COUNTY's Defaulted Property Tax Reduction Program.*

9. Uncured or Repeated Breach

CONTRACTOR does not timely cure any other Breach in accordance with item A or CONTRACTOR Breaches any of its Performance Obligations repeatedly or habitually, as determined by Director at their sole discretion, if a specific instance of failure or refusal has been previously cured. However, this Contractor Default will be excused for a period of seven days beginning on the first occurrence of that Contractor Default in the event of Uncontrollable Circumstances, if the event materially affects CONTRACTOR's ability to provide Contract Services. Nevertheless, if Uncontrollable Circumstances interrupt Collection, Customers and Occupants may take actions and COUNTY may exercise any of its rights under Section 11. This Contractor Default will not be excused if it continues for a period of more than seven days beginning on the first occurrence of this Contractor Default.

10. Improper Consideration

COUNTY finds that consideration, in any form, was offered or given by CONTRACTOR either directly or through an intermediary to any COUNTY officer, employee, or agent with the intent of securing this CONTRACT or securing favorable treatment with respect to the award, amendment, or extension of this CONTRACT or the making of any determinations with respect to CONTRACTOR's performance under this CONTRACT where that consideration may take any form including cash; discounts; service; or the provision of travel, entertainment, or tangible gifts.

11. Default Under Guaranty

A default exists under the guaranty, if any, provided in the most recent annual public financial Reports and other periodic public financial Reports of CONTRACTOR and, at Director's request, each of its Affiliates and other entities, if any, performing Contract Services or providing Goods or Services; provided however, that if CONTRACTOR did not submit its own financial Reports before the Execution Date of this CONTRACT, it must provide a guaranty in the form provided by Director, by a guarantor

satisfactory to Director, which guarantor must provide its own audited financial Reports;

C. Notice of Contractor Default

1. Effective Immediately

COUNTY may terminate this CONTRACT effective immediately after Notice by Director to CONTRACTOR of any of the following Contractor Defaults:

- a. Any Contractor Default, if COUNTY determines that protection of public health and safety requires immediate suspension or termination;*
- b. A Contractor Default in Part 3B3 of Exhibit 5 (failure to provide insurance, bonds);*
- c. A Contractor Default described in Part 3B4 of Exhibit 5 (material or repeated Violation of Applicable Law, including County Lobbyist Ordinance);*
- d. A Contractor Default described in Part 3B10 of Exhibit 5 (improper consideration).*

1. Effective 30 days

COUNTY may terminate this CONTRACT effective 30 days after Notice by Director to CONTRACTOR of any Contractor Default other than Contractor Defaults listed in this Part 3C1 of Exhibit 5 or termination events effective immediately in Part 3D of Exhibit 5 (suspension or termination of CONTRACT).

2. Effective 15 days

COUNTY may terminate this CONTRACT effective 15 days after Notice by Director to CONTRACTOR of COUNTY's right to terminate this CONTRACT in the event of Criminal Activity in accordance with Part 5I of Exhibit 5 and Part 3D2c of Exhibit 5.

3. Effective Ten days

COUNTY may terminate this CONTRACT effective ten days after Notice given by Director for failure to comply with County Defaulted Property Tax Reduction Program in accordance Part 3F of Exhibit 5.

D. Suspension or Termination of CONTRACT

1. Suspension

Together with any other rights COUNTY may have under this CONTRACT, Director may suspend this CONTRACT, in whole or in part, for a period of 45 days effective immediately upon Notice to CONTRACTOR in any of the following events:

a. *A Contractor Default*

b. *COUNTY Right*

COUNTY exercise of its right to suspend this CONTRACT under Part 5I of Exhibit 5 in the event of Criminal Activity of CONTRACTOR; or

c. *Other*

Any other Contractor Default in Exhibit 3A1.

During that 45-day period CONTRACTOR shall have the opportunity to demonstrate to Director that CONTRACTOR can once again fully perform Contract Services in accordance with this CONTRACT. If CONTRACTOR so demonstrates, COUNTY's right to suspend this CONTRACT will cease and CONTRACTOR may resume providing services. If CONTRACTOR does not so demonstrate, COUNTY may continue the suspension and terminate this CONTRACT and exercise any other rights and remedies under this CONTRACT.

2. Termination

a. *Contractor Default*

COUNTY may terminate this CONTRACT, in whole or in part, upon the occurrence of a Contractor Default and Notice to CONTRACTOR at the times provided in Part 3D3 of this Exhibit 5 (Suspension/Termination for Non-Appropriation of Funds).

b. *Failure to Agree on Service Rate Adjustments*

Notwithstanding the foregoing, COUNTY may terminate this CONTRACT on 6 months' Notice if in the judgment of Director, COUNTY and CONTRACTOR are unable to reach satisfactory CONTRACT to adjust Service Rates in accordance with item A1a(1) of Exhibit 7 for a Change in Law, Service Specifications, or Service Standards after good faith negotiations during a period of at least 30 days.

c. *Criminal Activity*

COUNTY may terminate this CONTRACT upon Notice required in Part 3C of Exhibit 5 if COUNTY exercises its right to terminate this CONTRACT under Part 5I of Exhibit 5 in the event of Criminal Activity of CONTRACTOR.

d. *Annexation/Dissolution of Service Area*

It is understood that in the event annexation or the dissolution of all or a portion of the Service Area, this CONTRACT and all obligations of either of the Parties thereto shall end and CONTRACTOR and COUNTY shall amend this CONTACT to delete the annexed area from the definition of Service Area. Such annexations/dissolution may result from proceedings under the provisions of the act pursuant to which the Service Area was created, by operation of law, resulting from municipal annexation or incorporation, or any other reason.

Upon request of Director, CONTRACTOR shall use Reasonable Business Efforts to cooperate with a local agency with respect to providing Collection Services or MSW Management Services, in the event the Service Area is annexed by that local agency in accordance with Applicable Laws.

COUNTY will provide information regarding any known annexations or incorporations at the proposers/bidder's conference; however, CONTRACTOR is responsible for investigating the Service Area and determining which areas are prone to annexation or incorporation. For example, the City of Santa Clarita has annexed portions of the unincorporated communities of the County of Los Angeles and it is reasonable to expect additional annexations during the Term of this CONTRACT.

3. Suspension/Termination for Nonappropriation of Funds

COUNTY shall not be obligated for CONTRACTOR's performance under this CONTRACT, with respect to County Services under this Exhibit during any of COUNTY's future Fiscal Years unless and until the Board appropriates funds for this CONTRACT in COUNTY's budget for each such future Fiscal Year. If funds are not appropriated for this CONTRACT, then this CONTRACT may be suspended or terminated as of June 30 of the last Fiscal Year for which funds were appropriated. Director will notify CONTRACTOR in writing of any such nonallocation of funds as soon as possible.

4. Suspension/Termination Requirements

a. *Stop Suspended/Terminated Work; Complete Non-Suspended/Terminated*

After receipt of a Notice of suspension or termination and except as otherwise directed by Director, CONTRACTOR shall:

- (1) Stop work under this CONTRACT on the date and to the extent specified in such Notice; and
- (2) Complete performance of such part of the work as shall not have been suspended or terminated by such Notice.

b. *Records Retention*

All material including books, Records, documents, or other evidence bearing on the costs and expenses of CONTRACTOR under this CONTRACT shall be maintained by CONTRACTOR in accordance with Section 9A and Part 1G of Exhibit 5.

c. *Completion of Work*

If this CONTRACT is suspended or terminated, CONTRACTOR shall complete within Director's suspension or termination date contained within the Notice of suspension or termination, those items of work which are in various stages of completion, which Director has advised CONTRACTOR are necessary to bring the work to a timely, logical, and orderly end. Reports, samples, and other materials prepared by CONTRACTOR under this CONTRACT shall be delivered to Director upon request and shall become the property of COUNTY.

d. *Suspension or Termination in Part*

COUNTY may suspend or terminate part of this CONTRACT.

E. CONTRACTOR Responsibility and Debarment

1. Child Support Compliance Program

COUNTY may debar CONTRACTOR from doing business with COUNTY if COUNTY determines after giving Notice and conducting a hearing in accordance with Chapter 2.202 of County Code, which shall apply to this CONTRACT, that CONTRACTOR (or any of its Subcontractors) is not responsible within the meaning of Chapter 2.202 and in accordance with

COUNTY's policy to do business with responsible contractors; CONTRACTOR's failure to comply with the Child Support Compliance Program, as provided in Part 7B of Exhibit 5, may be cause for debarment in accordance with Section 2.200.020 of County Code.

2. County Defaulted Property Tax Reduction Program

COUNTY may debar CONTRACTOR from doing business with COUNTY as provided in Part 3F2 of this Exhibit.

F. Termination For Breach Of Warranty To Maintain Compliance With County Defaulted Property Tax Reduction Program

1. Contractor Default

Failure of CONTRACTOR to maintain compliance with the requirements set forth in Part 7C of Exhibit 5 shall constitute a Contractor Default under Part 3B of Exhibit 5.

2. Termination/Debarment

Without limiting the rights and remedies available to COUNTY under any other provision of this CONTRACT, failure of CONTRACTOR to cure that Contractor Default within ten days of Notice shall be grounds upon which COUNTY may terminate this CONTRACT under Part 3D2a of Exhibit 5 and/or pursue debarment of CONTRACTOR pursuant to County Code Chapter 2.206 and Part 3E2 of Exhibit 5.

PART 4 - TRANSFER OF CONTRACT

A. COUNTY Consent

CONTRACTOR may not transfer this CONTRACT, any Franchise granted under it, or any rights or duties under it, in whole or in part, and whether voluntarily or involuntarily, without COUNTY's prior written consent given at COUNTY's sole discretion. Any transfer or attempted transfer of this CONTRACT, the franchise granted under it or any rights and duties under it, made without COUNTY's consent, at COUNTY's option, will be invalid. COUNTY's consent must be a written amendment to this CONTRACT that is executed by (1) CONTRACTOR and (2) the Board, or if delegated by the Board, Director. Any transfer, with or without consideration for any reason whatsoever without COUNTY's (or Director's, if applicable) express prior written approval, shall be a Breach of this CONTRACT, which may result in the termination of this CONTRACT. In the event of such termination, COUNTY shall be entitled to pursue the same remedies against CONTRACTOR as it could pursue in the event of default by CONTRACTOR. COUNTY may condition consent on payment of amounts specified in Exhibit 3A1 in consideration for the value of good will and intangibles that accrued to COUNTY and Customers and Occupants in the award of this CONTRACT to CONTRACTOR.

"Transfer" means an action (or inaction) that has any of the following direct (or indirect) effects:

1. Control or Ownership of CONTRACTOR

Changing any or all of the following:

- The effective control of CONTRACTOR, or
- Ownership interest of CONTRACTOR (including buyout, merger, acquisition, consolidation, reorganization, recapitalization, stock (re)issuance, voting trust, pooling agreement, escrow arrangement, dissolution, or liquidation (except to Immediate Family or a trust created primarily to benefit members of the Immediate Family) unless CONTRACTOR proves to satisfaction of COUNTY less than 25 percent of ownership interest has changed;

2. Control or Ownership of Contract Service Assets

Changing either or both of the following:

- The effective control.
- The ownership (actual or constructive) of Contract Service Assets

(except for sales or transfers to the Immediate Family or a trust created primarily to benefit the Immediate Family) unless CONTRACTOR proves to satisfaction COUNTY that less than 20 percent of the value of Service Assets has changed ownership.

3. Someone Other Than CONTRACTOR Performing Contract Services

Resulting in someone other than CONTRACTOR performing contract services or assuming the obligation to provide Contract Services (including substitution of someone else by a surety company providing a performance bond, franchise assignment, transfer, conveyance, sublease, or licensing).

For purposes of this definition, an action (or inaction) includes assignment by operation of law, such as insolvency or bankruptcy, making assignment for the benefit of creditors, writ of attachment of an execution levied against this Agreement, appointment of a receiver taking possession of any of CONTRACTOR's tangible or intangible property, or transfer occurring in a probate or other estate proceeding.

“Immediate Family” means parents, grandparents, siblings, children, and grandchildren of individuals having a shareholder or other equity interest in CONTRACTOR as of the Execution Date.

“ownership” means the state or fact of being the direct (or indirect), actual (or constructive) owner of property, including a parent holding corporation owning stock of a subsidiary corporation that in turn owns stock in its own subsidiary corporation(s).

B. **CONTRACTOR Demonstration**

Without obligating Director to give consent, CONTRACTOR shall demonstrate to Director's satisfaction that the proposed transferee has the operational and financial ability to satisfy CONTRACTOR's Performance Obligations.

C. **Payment of COUNTY's Transfer Costs**

1. Transfer Deposit

CONTRACTOR must make any request for Director's consent to a transfer in the manner prescribed by Director. Director may condition consent to any transfer, other than a transfer to an Affiliate of CONTRACTOR, on CONTRACTOR's payment to COUNTY of \$5.00 per Customer. CONTRACTOR shall pay COUNTY a transfer Deposit before Director's consideration of CONTRACTOR's request. COUNTY will return to CONTRACTOR any amounts paid more than the transfer Costs incurred.

2. Additional Transfer Costs

While COUNTY's Processing CONTRACTOR's request for transfer, CONTRACTOR shall further pay COUNTY the difference between the Transfer Deposit and the payment to COUNTY of the \$5.00 per Customer fee for Transfers other than to an Affiliate of CONTRACTOR within 30 days of Director's request therefore, if Director approves the transfer. At CONTRACTOR's request, COUNTY will provide CONTRACTOR access to all Records evidencing the transfer Costs incurred.

D. County's Reimbursement Costs of Enforcement

In addition, CONTRACTOR shall pay County's Reimbursement Costs for fees and investigation costs as COUNTY may deem necessary to enjoin the transfer or to otherwise enforce this provision within 30 days of COUNTY's request therefore.

Any payment by COUNTY to any approved delegate or transferee on any claim under this CONTRACT shall be deductible, at COUNTY's sole discretion, against the claims which CONTRACTOR may have against COUNTY.

PART 5 - GENERAL PROVISIONS

A. Exercise of Options

Parties will exercise any approval, disapproval, consent, judgment, option, discretion, election, opinion, or choice under this CONTRACT, make a requirement under this CONTRACT or interpret this CONTRACT ("Discretionary Action") reasonably. Any mediator, arbitrator, or court must find the Party's exercise to be reasonable. Recognizing the essential public health and safety protections this CONTRACT serves, where this CONTRACT specifically provides that the exercise of any Discretionary Action is in either Party's independent, sole, exclusive, or absolute discretion, control, or judgment, the other Party will not question or challenge the first Party's exercise thereof. Parties will nevertheless exercise their rights and remedies in good faith in accordance with Applicable Law.

B. Independent Status

CONTRACTOR is an independent entity and not an officer, agent, servant, or employee of COUNTY. This CONTRACT is between COUNTY and CONTRACTOR and is not intended, and will not be construed, to create the relationship of agent, servant, employee, partnership, joint venture, or association between COUNTY and CONTRACTOR, including for purposes of workers' compensation. CONTRACTOR is solely responsible for the acts and omissions of its officers, agents, employees, and any Subcontractors. Nothing in this CONTRACT will be construed as creating an arrangement for handling Unpermitted Waste. CONTRACTOR bears the sole responsibility and liability for furnishing workers' compensation and all other benefits required by law to any individual for injuries arising from or connected with Contract Services performed on behalf of CONTRACTOR under this CONTRACT.

C. Damage to Property and Personal Injury

CONTRACTOR shall not cause damage to property or personal injury. At its sole expense, CONTRACTOR shall repair or replace in an attempt to satisfy the owner of damaged property, any physical damage to public or private property and shall reimburse in an attempt to satisfy the injured individual, the cost of any personal injury caused by the negligent or willful acts or omissions of CONTRACTOR. COUNTY may refer all complaints of damage or injury to CONTRACTOR as a matter within CONTRACTOR's sole responsibility. Notwithstanding any Rights COUNTY has for breach of CONTRACT, disputes between CONTRACTOR and Persons as to damage to private pavement or other property or to injury are civil matters between CONTRACTOR and that Person, and the Person may institute suits with respect thereto as allowed by law.

D. Venue

In the event of litigation between the Parties, venue in State of California trial courts will lie exclusively in COUNTY. In the event of litigation in a United States District Court, exclusive venue will lie in the Central District of California.

E. Changes and Amendments

1. Changes following Notice

The following changes in this CONTRACT after the Execution Date will be effective after Notice from Director to CONTRACTOR (or with respect to certain changes referenced in item b, from CONTRACTOR to Director, in accordance with Section 17 item B2, CONTRACTOR Documentation, as consented to by CONTRACTOR:

- a. Changes in the scope of Contract Services and Service Specifications and minimum Service Standards that do not result in a Customer Service Rate adjustment in accordance with Section 3C or change in County Service Rate*
- b. Changes to Exhibit 17 Contractor Documentation*
- c. Changes to Attachment 5-8G Authorized Representative of COUNTY's Director*
- d. Immaterial changes to immaterial Performance Obligations*

2. Written Amendments

The following changes in this CONTRACT after the Execution Date will be effective only upon execution of a written amendment to this CONTRACT, including warranties by the Parties in accordance with Section 14B:

- a. Changes in the scope of Contract Services and Service Standards that result in a Customer Service Rate adjustment in accordance with Section 3C; and*
- b. Material changes to material Performance Obligations (such as the period of performance, payments, or any material Term or condition included in this CONTRACT).*

F. Notices

All Notices required or permitted to be given under this CONTRACT must be in writing with proof of delivery and acknowledgment by recipient. All Notices to COUNTY must be addressed to Director as provided in Attachment 5-8G, on CONTRACTOR letterhead, and signed by authorized representative. All Notices to CONTRACTOR must be addressed to the authorized representative of

CONTRACTOR named in Contractor Documentation in Exhibit 17 (who will be CONTRACTOR's primary contact under this CONTRACT).

COUNTY Notice to CONTRACTOR is deemed effective on the date delivered with evidence of receipt or three days after the date of mailing, as evidenced in proof of mailing and post-marked date on envelope.

Notices of suspension or termination of this CONTRACT may be personally delivered to any individual whose actual knowledge of suspension or termination would be sufficient Notice to CONTRACTOR, including:

1. **An individual, if CONTRACTOR is a sole proprietor;**
2. **Copartner, if CONTRACTOR is a partnership; or**
3. **The president, vice president, secretary, or general manager, if CONTRACTOR is a corporation.**

G. Authorized Representative of Director

COUNTY authorizes Director to make requests or requirements of CONTRACTOR or give approvals under this CONTRACT, excluding consents to transfer or written amendments of this CONTRACT. The authorized representative of Director named in Attachment 5-8G is CONTRACTOR's primary contact under this CONTRACT and can be contacted as provided in Attachment 5-8G. CONTRACTOR shall give that authorized representative a copy of all Notices in accordance with Part 5F of Exhibit 5. From time to time, Director may change Attachment 5-8G by Notice to CONTRACTOR.

H. Authority and Representations; COUNTY Disclaimer

1. COUNTY

COUNTY represents and disclaims as follows:

a. Status

COUNTY is a political subdivision of the State of California.

b. Authority and Authorization

COUNTY has full legal right, power, and authority to execute and deliver this CONTRACT and perform its obligations under this CONTRACT. This CONTRACT has been duly executed and delivered by COUNTY and constitutes a legal, valid, and binding obligation of COUNTY enforceable against COUNTY in accordance with its terms.

2. CONTRACTOR

CONTRACTOR represents and warrants as provided in Attachment 5-8H.

I. Criminal Activity

1. Notice

CONTRACTOR shall immediately give Notice to Director on the occurrence of any convictions of a Criminal Activity or any pleas of "guilty," "nolo contendere," or "no contest" to a Criminal Activity with respect to CONTRACTOR or any of its Contractor Managers (except for Contractor Managers in a Position of Influence). CONTRACTOR shall use Reasonable Business Efforts to immediately give Notice to Director on the occurrence of any convictions or any pleas with respect to CONTRACTOR or any of its Contractor Managers in a Position of Influence, and any of its CONTRACTOR employees who come in direct contact with the residents.

2. CONTRACTOR Cure

Upon the occurrence of any conviction or any plea described in Part 511 of Exhibit 5, CONTRACTOR immediately shall do or cause to be done both of the following:

a. *Terminate*

Terminate from employment or remove from office any offending Contractor Manager who is an individual, or with respect to CONTRACTOR or an Affiliate, the individual or individuals responsible for the Criminal Activity; and

b. *Eliminate*

Eliminate the participation in management of CONTRACTOR by that Contractor Manager who is an individual or, with respect to CONTRACTOR or an Affiliate, the individual or individuals responsible for the Criminal Activity from any Position of Influence.

3. COUNTY Remedies

COUNTY may suspend or terminate this CONTRACT or may impose other sanctions (which may include financial sanctions or any other condition deemed appropriate short of suspension or termination), as it deems proper, in either or both the following events:

- a. *CONTRACTOR or any Affiliate fails to effectuate the cure described in Part 5I2 of Exhibit 5; or*
- b. *The Criminal Activity is related to this CONTRACT or occurring in COUNTY.*

4. Limitations on Contractor Manager

No Contractor Manager may have previously been convicted of a Criminal Activity or any plea of "guilty," "nolo contendere," or "no contest" to a Criminal Activity.

5. Contractor Documentation

CONTRACTOR shall list all Contractor Managers in Contractor Documentation in Exhibit 17.

J. Delay of Performance Obligations

Immediately upon learning that any actual or potential circumstance is delaying or threatening to delay the timely satisfaction of a Performance Obligation, CONTRACTOR shall give Director a Notice of the delay, including all relevant information, such as identifying the Performance Obligation, circumstance, and duration of the delay, and whether or not CONTRACTOR believes that the delay is due to Uncontrollable Circumstances. CONTRACTOR shall propose a solution for Director approval.

K. Subcontractors

CONTRACTOR shall not engage any Subcontractor in an amount exceeding \$50,000 for any individual Subcontractor without prior Director approval of the Subcontract and Subcontractor. CONTRACTOR is responsible for directing the work of CONTRACTOR's Subcontractors and any compensation due or payable to CONTRACTOR's Subcontractors is the sole responsibility of CONTRACTOR. CONTRACTOR shall ensure that the Subcontractor is able to perform all Performance Obligations under this Contract. CONTRACTOR shall remove any approved Subcontractor for good cause at Director's request. CONTRACTOR shall identify all Subcontractors in Contractor Documentation in Exhibit 17. In its Annual Report, CONTRACTOR shall disclose to Director the name of all Subcontractors, the amount of Goods or Services that each Subcontractor provides to CONTRACTOR, and a description of CONTRACTOR's relationships to each Subcontractor (including ownership interests).

PART 6 - DEFINITIONS AND INTERPRETATION OF CONTRACT

A. Definitions

Defined words in this CONTRACT have the meanings given in Attachment 5-10A.

B. Interpretation and Construction

1. Gender and Plurality

Words of the masculine gender include correlative words of the feminine and neuter genders and vice versa. Words importing the singular number include the plural number and vice versa unless the context demands otherwise. (For example, reference to a defined "Solid Waste Facility" may include reference to more than one facility identified by CONTRACTOR in Contractor Documentation in Exhibit 17.)

2. Headings; Font

Any captions or headings following the Exhibit, Attachment, Section, subsection, paragraph, and other attachments and subdivisions of this CONTRACT that precede the operative text of this CONTRACT are for convenience of reference only and do not control or affect the scope, intent, meaning, construction, interpretation, or effect of this CONTRACT. Any underlined, italicized, bold-faced, upper captioned or other font style is for ease of reading and contract administration only and does not imply relative importance or unimportance of any provision of this CONTRACT.

3. References to Parts

References to Sections refer to Sections of this CONTRACT, unless specified otherwise. References to Exhibits and Attachments refer to Exhibits and Attachments attached to this CONTRACT. Reference to "subsections" refers to the subsections contained in the same Section in which the reference occurs, unless otherwise referenced.

4. Examples

Examples are for purpose of illustration only. If any example is ambiguous, inconsistent, or conflicts with the text that it illustrates, the text governs.

5. Specifics No Limitation on Generalities

The mention of any specific duty or liability imposed on CONTRACTOR may not be construed as a limitation or restriction of any general liability or duty imposed on CONTRACTOR by this CONTRACT or Applicable Law.

6. Exhibits

The exhibits to this CONTRACT, including their attachments, are part of this CONTRACT to the same extent and effect as if included in the text of Sections 1 through 17.

7. Inconsistencies and Conflicts

- a. If any provision of Exhibit 3A1 (Collection Services) is inconsistent or conflicts with Sections 1 through 17 or Exhibit 5 (Additional Contract Provisions) of this CONTRACT or any other Exhibits or Attachments to this CONTRACT, then the provisions of Exhibits 3A1 will govern, and
- b. If any provision of Sections 1 through 17 or Exhibit 5 (Additional Contract Provisions) of this CONTRACT is inconsistent or conflicts with any Exhibit (other than Exhibits 3A1), including Contractor Documentation, then the provision of Sections 1 through 17 or Exhibit 5 of this CONTRACT will govern unless Director determines that it is contrary to the interest of the Parties.

C. Integration

This CONTRACT contains the entire CONTRACT between the Parties with respect to the rights and responsibilities of the Parties under this CONTRACT. This CONTRACT completely and fully supersedes all prior oral and written understandings and contracts between the Parties with respect to those rights and responsibilities.

D. Governing Law

This CONTRACT is governed by, and construed and enforced in accordance with the law of the State of California, without giving effect to the State's principles of conflicts of laws.

E. Severability

If any clause, sentence, provision, subsection, or Section of this CONTRACT or Exhibit to this CONTRACT (an "Contract Provision") is ruled illegal, invalid, nonbinding, or unenforceable by any court of competent jurisdiction, then the Parties will take the following actions:

1. Promptly meet and negotiate a substitute for the CONTRACT Provision and any related amendments, deletions, or additions to other provisions of this CONTRACT, which together effect the Parties' original intent to the greatest extent allowable under Applicable Law; and

2. If necessary or desirable to accomplish preceding item 1, apply to the court that declared the invalidity for a judicial construction of the substituted CONTRACT Provision and any amendments, deletions, or additions to this CONTRACT. Within ten days of Director's request, CONTRACTOR shall pay COUNTY an amount equivalent to 100 percent of the Direct Costs of the application.

The illegality, invalidity, nonbinding nature, or unenforceability of any CONTRACT Provision will not affect any of the remaining provisions of this CONTRACT, and this CONTRACT will be construed and enforced as if the CONTRACT Provision did not exist.

F. Interpretation

This CONTRACT will be interpreted and construed neither for nor against either Party, regardless of the degree to which either Party participated in its drafting. CONTRACTOR acknowledges that it determined to provide Contract Services in the Service Area and to execute this CONTRACT upon CONTRACTOR's own choice and initiative. Each Party represents and warrants that it and its counsel have reviewed this CONTRACT, and the Parties agree that no provision in this CONTRACT will be construed against the drafting Party.

PART 7 - COMPLIANCE WITH LAWS AND REGULATIONS

A. Applicable Law

1. Compliance

CONTRACTOR shall secure and maintain all Permits, licenses, registration, agreements, and comply with all Applicable Laws, including (as required by 13 CCR 2021.1) all applicable air pollution control laws such as Diesel Particulate Matter Control Measure of on-road, heavy-duty, and the Property Tax Reduction Ordinance. No obligation in this CONTRACT may be construed to relieve CONTRACTOR of any obligations imposed by Applicable Law.

CONTRACTOR shall be fully responsible for possessing and keeping current and/or obtaining any required licenses/Permits from the appropriate Federal, State, or local authorities for work to be accomplished under this CONTRACT, including, but not limited to, a valid Waste Collector Permit issued by County Department of Public Health, Green Waste Quarantine Zone compliance agreement from California Department of Food and Agriculture, waste and used tire hauler registration from CalRecycle, and hazardous waste transportation Permit from CalRecycle.

CONTRACTOR shall secure and maintain valid waste and used tire hauler registration therefore in accordance with California Public Resources Code Section 42950 et seq. and any Permit required by Applicable Law for handling E-waste. CONTRACTOR shall transport tires to and Dispose of them at a facility authorized and permitted in accordance with Applicable Law to accept tires. CONTRACTOR shall comply with all applicable regulations governing the recovery of ozone-depleting refrigerants during the Disposal of air conditioning or refrigeration equipment, including 40 C.F.R. Part 82.

2. Referenced Provisions

References in this CONTRACT to provisions or requirements of Applicable Law may not be construed to limit CONTRACTOR's obligation to comply with all provisions of Applicable Law. Those references are intended to facilitate CONTRACTOR's satisfaction of its Performance Obligations and COUNTY's administration and specific enforcement of this CONTRACT and may not be construed to constitute lack of obligation to comply with other provisions or requirements of Applicable Law not specifically referred to or cited in this CONTRACT. If any provision of this CONTRACT is more stringent than Applicable Law, CONTRACTOR shall comply with that provision.

3. Fines and Penalties

CONTRACTOR is solely liable for all fines and penalties that may be imposed on CONTRACTOR or may be due to CONTRACTOR's actions, including fines and penalties that are the result of CONTRACTOR's Violation of Applicable Law (including Permits). CONTRACTOR shall not seek reimbursement from COUNTY, Customers, or Occupants for any fines or penalties.

4. Contractual Obligations

Provisions of Applicable Law are incorporated in this CONTRACT by reference as if set forth fully in this CONTRACT as contractual obligations of CONTRACTOR to COUNTY.

a. Breaches

In addition to or in lieu of prosecuting violations of those provisions as misdemeanors, infractions, or otherwise in the manner provided under Applicable Law, COUNTY may enforce those provisions in the same manner as it may enforce CONTRACTOR's other contractual obligations under this CONTRACT, including specific performance and as Breaches subject to cure in accordance with Part 3A of Exhibit 5. However, COUNTY has no obligation to enforce any Applicable Law.

b. Violation

Violation of Applicable Law is a Contractor Default subject to contest as provided in Part 3B4 of Exhibit 5.

5. COUNTY's Protection of Public Safety, Health, and Welfare

CONTRACTOR acknowledges that COUNTY is authorized to make all necessary and reasonable rules and regulations regarding all aspects of MSW Management Services to protect the public's health, safety, and welfare.

No provision in this CONTRACT is deemed to limit the power of COUNTY to regulate CONTRACTOR or to take any action as COUNTY deems appropriate or necessary in Director's sole and absolute discretion, under COUNTY's police power, including to protect the public's health, safety, and welfare.

6. Compliance with Applicable Law of COUNTY

CONTRACTOR shall comply with Applicable Law of COUNTY subject to possible adjustments in the Service Rates in the event of Changes in Law in accordance with items in Exhibit 7.

B. COUNTY Child Support Compliance Program

As required by COUNTY's Child Support Compliance Program (County Code Chapter 2.200), CONTRACTOR shall fully comply with employment and wage reporting requirements under the Federal Social Security Act (42 U.S.C. Section 653(a) and California Unemployment Insurance Code Section 1088.5. CONTRACTOR shall implement lawfully served wage and earnings withholding orders or COUNTY Child Support Services Department Notices of wage earnings assignment for child, family, or spousal support issued in accordance with California Code of Civil Procedure Section 706.031 and California Family Code Section 5246(b).

C. County Defaulted Property Tax Reduction Program

CONTRACTOR acknowledges that COUNTY has established a goal of ensuring that all individuals and businesses that benefit financially from COUNTY through contract are current in paying their property tax obligations (secured and unsecured roll) to mitigate the economic burden otherwise imposed upon COUNTY and its taxpayers.

Unless CONTRACTOR qualifies for an exemption or exclusion, CONTRACTOR warrants and certifies to the best of its knowledge under Attachment 5-9H, that as of the Execution Date it complies with County Code Chapter 2.206. Unless CONTRACTOR qualifies for an exemption or exclusion, CONTRACTOR shall comply with County Code Chapter 2.206.

PART 8 - LABOR-RELATED PROVISIONS REQUIRED IN COUNTY CONTRACTS

A. Labor Code

CONTRACTOR and its agents and employees are bound by and shall comply with all applicable provisions of the California Labor Code as well as all other Applicable Laws related to labor. By and through its execution of this CONTRACT, CONTRACTOR represents and warrants that it is aware of and understands the provisions of California Labor Code Section 3700, which requires every employer to be insured against liability of Workers' Compensation or to undertake self-insurance in accordance with those provisions before commencing the performance of work under this CONTRACT and agrees to fully comply with those provisions.

B. Notices to Employees

1. Regarding the Federal Earned Income Credit

CONTRACTOR shall notify its employees and shall require each Subcontractor performing Contract Services to notify its employees, that they may be eligible for the Federal Earned Income Credit under the Federal income tax laws. The Notice must be provided in accordance with the requirements set forth in Internal Revenue Service Notice 1015 that CONTRACTOR has attached as Contractor Documentation.

2. Regarding Safely Surrendered Baby Law

CONTRACTOR acknowledges that COUNTY places a high-priority on the implementation of the Safely Surrendered Baby Law (SB 1368).

a. Fact Sheet

CONTRACTOR shall notify and provide to its employees and shall require each Subcontractor performing Contract Services to notify and provide to Subcontractors' employees a fact sheet regarding the Safely Surrendered Baby Law, its implementation in COUNTY, and where and how to safely surrender a baby. CONTRACTOR shall print and make available in every facility where its employees are present, including Offices and operation yards, the fact sheet that is available at www.babysafela.org.

b. Poster

CONTRACTOR understands that it is COUNTY's policy to encourage all COUNTY contractors to voluntarily post COUNTY's "Safely Surrendered Baby Law" poster in a prominent position at CONTRACTOR's place of business. CONTRACTOR shall also

encourage its Subcontractors to post this poster in a prominent position in the Subcontractors' place of business. COUNTY's Department of Children and Family Services will supply CONTRACTOR with the poster to be used.

3. Regarding Child Support

CONTRACTOR acknowledges that COUNTY places a high priority on the enforcement of child support laws and the apprehension of child support evaders. CONTRACTOR further acknowledges that it is COUNTY's policy to encourage all COUNTY contractors to voluntarily post COUNTY's "L.A.'s Most Wanted: Delinquent Parents List" supplied by COUNTY in a prominent position at their place of business.

4. Time Off for Voting

CONTRACTOR shall notify its employees and shall require each Subcontractor to notify and provide to its employees, information regarding the time off for voting law (Elections Code, Section 14000). Not less than ten days before every Statewide election, every CONTRACTOR and Subcontractors shall keep posted conspicuously at the place of work, if practicable, or elsewhere where it can be seen as employees come or go to their place of work, a Notice setting forth the provisions of Section 14000.

C. Prohibition Against Use of Child Labor

1. Compliance with International Labor Organization Convention Concerning Minimum Age for Employment

CONTRACTOR shall not knowingly sell or supply to COUNTY or Customers and Occupants any products, goods, supplies, or other personal property manufactured in violation of child labor standards set by the International Labor Organization through its 1973 Convention Concerning Minimum Age for Employment (the "Convention Concerning Minimum Age for Employment"). If CONTRACTOR discovers that any products, goods, supplies, or other personal property sold or supplied by CONTRACTOR to COUNTY or any Customer are produced in violation of that Convention, CONTRACTOR shall immediately provide an alternative source of supply that complies with that Convention.

2. Provide COUNTY with Records

At COUNTY's request, CONTRACTOR shall provide documentation satisfactory to COUNTY evidencing the country or countries of origin of any products, goods, supplies, or other personal property CONTRACTOR sells or supplies to COUNTY or any Customer or Occupant relating to Contract Services.

3. Provide COUNTY with Manufacturers' Certification

At COUNTY's request, CONTRACTOR shall provide to COUNTY the manufacturer's certification of compliance with the Convention Concerning Minimum Age for Employment or other all-international child labor conventions.

D. Nondiscrimination

1. Employees

CONTRACTOR and its Affiliates shall employ qualified applicants and treat employees equally without regard to or because of race, color, national origin, ancestry, religion sex, age, physical or mental disability, marital status, or political affiliation and in compliance with all State of California and Federal antidiscrimination laws, including in employment, upgrading, demotion, transfer, recruitment, recruitment advertising, layoff, termination, Service Rates of pay, other forms of compensation, and selection of training (including apprenticeship).

2. Subcontractors, Proposers/Bidders, and Vendors

CONTRACTOR shall deal with its Subcontractors, proposers/bidders, and vendors without regard to or because of race, color, national origin, ancestry, religion, sex, age, physical or mental disability, marital status, or political affiliation.

3. Certification

CONTRACTOR shall comply with the provisions of CONTRACTOR's EEO Certification (Form PW-7), attached as Contractor Documentation.

4. Inspection of Records

At COUNTY's request, CONTRACTOR shall Promptly allow COUNTY and its auditors or reviewer access to CONTRACTOR's employment Records at CONTRACTOR's Office during Contractor Office Hours to verify compliance with the provisions of Part 8D4 of Exhibit 5.

5. Remedies for Discrimination

If COUNTY finds that CONTRACTOR has violated any provisions of this subsection D, that violation constitutes a Contractor Default. While COUNTY reserves the right to determine independently that the antidiscrimination provisions of this subsection D have been violated, in addition, a determination by the California Fair Employment Practices

Commission or the Federal Equal Employment Opportunity Commission that CONTRACTOR has violated State of California or Federal antidiscrimination laws will constitute a finding by COUNTY that CONTRACTOR has violated the antidiscrimination provisions of Part 8D of Exhibit 5.

E. Safety

1. Services Safety Official

CONTRACTOR shall designate in Contractor Documentation in Exhibit 17 a Services Safety Official who shall be thoroughly familiar with CONTRACTOR's Injury and Illness Prevention Program (IIPP) and Code of Safe Practices (CSP). CONTRACTOR shall ensure that the Services Safety Official is available always Contract Services are provided to abate any potential safety hazards. CONTRACTOR shall give the Services Safety Official the authority and responsibility to cease performing any service if necessary to abate any potential safety hazard. If CONTRACTOR fails to designate or make available the Services Safety Official, COUNTY may direct CONTRACTOR to cease providing Contract Services at no cost to COUNTY until CONTRACTOR complies with this Section.

2. Safety Responsibilities

CONTRACTOR is responsible for the safety of equipment, material, and personnel under CONTRACTOR's control or authority during performance of Contract Services. CONTRACTOR is solely responsible for ensuring that all work performed under this CONTRACT is performed in strict compliance with all Applicable Laws with respect to occupational safety regulations. CONTRACTOR shall provide at its expense all safeguards, safety devices, protective equipment, and shall take all actions appropriate to providing a safe job environment.

F. COUNTY Lobbyists

CONTRACTOR and each COUNTY lobbyist or COUNTY lobbying firm as defined in County Code Section 2.160.010, retained by CONTRACTOR shall fully comply with County Lobbyist Ordinance.

ATTACHMENT 5-8G – Authorized Representative of COUNTY’s Director

Name: Clark Ajwani

Telephone Number: (626) 458-5163

E-mail Address: cajwani@pw.lacounty.gov

Address for Notices by Mail:

Los Angeles County Public Works
Environmental Programs Division
P.O. Box 1460
Alhambra, CA 91802-1460

Director’s Office Hours : 7 a.m. to 5:30 p.m. Monday - Thursday
Established by Director

Signature:  _____

Printed Name: Clark Ajwani

Date: 08/17/22

Acknowledged by CONTRACTOR:

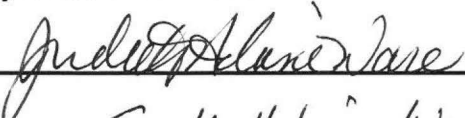
Signature:  _____

Printed Name: Judith Helene Ware

Title: President, CEO

Date: 9/20/2022

ATTACHMENT 5-8H – CONTRACTOR’s Representations and Warranties

A. Status

CONTRACTOR is duly organized, validly existing and in good standing under the laws of and is qualified to do business in the State of California with full power and authority to execute and deliver this CONTRACT and to perform its Performance Obligations. This CONTRACT has been duly executed and delivered by CONTRACTOR and constitutes a legal, valid, and binding obligation of CONTRACTOR enforceable against CONTRACTOR in accordance with its terms.

B. Statements and Information

All information and documentation compiled, drafted, made, or otherwise delivered to COUNTY by or on behalf of CONTRACTOR relating to this CONTRACT, including its procurement, is correct and complete in all material respects as of the Execution Date and at the time originally submitted by CONTRACTOR to COUNTY.

C. No Conflicts

Neither the execution or delivery by CONTRACTOR of this CONTRACT, the performance by CONTRACTOR of Contract Services, nor the fulfillment by CONTRACTOR of the terms and conditions of this CONTRACT: (1) conflicts with, violates, or results in a breach of any Applicable Law; (2) conflicts with, violates, or results in a breach of any Term or condition of any judgment, order or decree of any court, administrative agency or other governmental authority, or any CONTRACT or instrument to which CONTRACTOR is a Party or by which CONTRACTOR properties or assets are bound, or constitutes a default.

D. No Approvals Required

CONTRACTOR has obtained and maintains all Permits in full force and effect during the Term. No other approval, authorization, license, Permit, order, or consent of, or declaration, registration, or filing with any governmental or administrative authority, commission, board, agency, or instrumentality is required for the valid execution and delivery of this CONTRACT by CONTRACTOR, except those as have been duly obtained from its governing body, CONTRACTOR shall immediately provide Notice to Director of any Notice of violation, revocation, or suspension of any Permit.

E. No Litigation

As of the Execution Date, disclose any action, suit, proceeding, or investigation, at law or in equity, before or by any court or governmental authority, commission, board, agency or instrumentality pending or, to the best of CONTRACTOR’s knowledge, threatened, against CONTRACTOR wherein an unfavorable decision, ruling or finding, in any single case or in the aggregate, would materially adversely

affect the performance by CONTRACTOR of its obligations under this CONTRACT or in connection with the transactions contemplated by this CONTRACT, or which, in any way, would adversely affect the validity or enforce ability of this CONTRACT or any other CONTRACT or instrument entered into by CONTRACTOR relating to the transactions contemplated by this CONTRACT.

F. Due Diligence

As of the Execution Date, CONTRACTOR has made an independent investigation, examination, and research satisfactory to it of the conditions and circumstances surrounding this CONTRACT and best and proper method of providing Contract Services and labor, equipment, and materials for the volume of Contract Services to be provided. CONTRACTOR agrees that it shall make no claim against COUNTY based on any estimates, statements or interpretations made by any officer, employee, agent, or consultant of COUNTY relating to the procurement of this CONTRACT, which proves to be in any respect erroneous.

G. Compliance with Applicable Law

As of the Execution Date, CONTRACTOR has fully complied with all Applicable Law, including (1) law relating to conflicts of interest and County Lobbyist Ordinance, while procuring this CONTRACT, and (2) County Defaulted Property Tax Reduction Program.

H. Ability to Perform

CONTRACTOR possesses the business, professional, and technical capabilities to provide Contract Services; and possesses the equipment, facilities, and employee resources required to fully and timely perform Contract Services.

I. Contingent Fees

No Person, including a selling agency, has been employed or retained to solicit or secure this CONTRACT upon a CONTRACT or understanding for a commission, percentage, brokerage, or contingent fee, excepting bona fide employees or bona fide established commercial or selling agencies maintained by CONTRACTOR for securing business.

J. Opportunity to Comment

CONTRACTOR had the opportunity to submit comments and recommended changes during the procurement process, during meetings convoked by COUNTY with the denominated "Working Group" whose members received copies of the drafts of the form of CONTRACT or during the procurement of this CONTRACT.

K. Solid Waste Facilities

1. The Solid Waste Facility or Facilities that CONTRACTOR designates in Contractor Documentation in Exhibit 17 for Disposal is a Disposal facility that is permitted to accept and Process Refuse in accordance with Applicable Law.
2. The facility or facilities that CONTRACTOR designates in Contractor Documentation in Exhibit 17 for delivery of Recyclables is a materials recovery facility that is permitted to accept and Process Recyclables in accordance with Applicable Law.
3. The facility or facilities that CONTRACTOR designates in Contractor Documentation in Exhibit 17 for delivery of Organic Waste is a facility that is permitted to accept and Process Organic Waste in accordance with Applicable Law.

L. Contractor Documentation

As of the Execution Date, CONTRACTOR has submitted all Contractor Documentation in accordance with Exhibit 17.

M. Personnel

CONTRACTOR fully complies with all Federal and State statutes and regulations regarding employment of aliens and others, and all of its employees performing Contract Services meet the citizenship or alien status requirements set forth in Federal and State statutes and regulations.

ATTACHMENT 5-9A - Definitions

Affiliate means a Person that, directly or indirectly through one or more intermediaries, controls, or is controlled by, or is under common control with CONTRACTOR.

Annual Report is described in item A2 of Section 10.

Applicable Law means all laws, statutes, rules, regulations, guidelines, Permits, licenses, policies, actions, determinations, orders, or requirements of the United States, State of California, COUNTY (including its County Code together with rules and regulations promulgated there under and COUNTY's Integrated Waste Management Plan), the Local Enforcement Agency, California Highway Patrol, South Coast Air Quality Management District, and other regional or local government authorities, agencies, boards, commissions, courts, or other bodies having applicable jurisdiction, that from time to time apply to or govern Contract Services or the performance of the Parties' respective obligations under this CONTRACT, including those that concern health, safety, fire, mitigation monitoring plans, building codes, and zoning, and further including the following:

- Vehicles:
 - California Health and Safety Code Section 43000 et seq., with respect to air emissions (smog checks);
 - California Vehicle Code Section 27456b, with respect to tires;
 - California Vehicle Code Section 34500 et seq., with respect to documentation through its maintenance log or otherwise of a safety compliance report issued under Division 14.8 of the California Vehicle Code as applicable to each Vehicle, including bi-annual "BIT" inspections conducted by the California Highway Patrol;
 - Rules and regulations promulgated under the California Vehicle Code with respect to Vehicle highway lighting, flashing, and warning lights, clearance lights, and warning flags;
 - Rules and regulations of the California Department of Motor Vehicles with respect to Vehicle registration;
 - Vehicle weight limits;
 - The appropriate class of drivers' licenses issued by the California Department of Motor Vehicles;
 - Control Measure for Diesel Particulate Matter from On-road Heavy-Duty Residential and Commercial Solid Waste Collection Vehicles, 13 CCR 2020 et seq.; and
 - 14 CCR 17341, 17342, 17343 and 17344, with respect to equipment construction, safety, and parking and identification of operating equipment;
- Containers:
 - 14 CCR 17314, with respect to maintenance and placement of Containers; and
 - 14 CCR 17317, with respect to placing identifying name and telephone number on Containers;

- Labor:
 - Drug and alcohol testing;
 - Occupational Safety and Health Act (29 U.S.C. Section 651 et seq.), including the Solid Waste Disposal Facility Criteria promulgated by the U.S. EPA on October 9, 1991 (40 C.F.R., Parts 257 and 258); and California Occupational Safety and Health Act (California Labor Code, Division 5, Parts 1-10, Section 6300 et seq.), and rules and regulations of California Division of Occupational Safety and Health; and
 - Immigration Reform and Control Act of 1986 (PL.99-603);
- Environmental Protection:
 - CERCLA;
 - RCRA;
 - Clean Air Act (42 U.S.C. Section 1351 et seq., 42 U.S.C. Section 7401-7642); and California Clean Air Act (California Health and Safety Code Section 39000 et seq.);
 - California Hazardous Waste Control Act (California Health and Safety Code Section 25100 et seq.);
 - California Hazardous Materials Release Response Plan and Inventory Act (California Health and Safety Code, Division 20, Chapter 6.95, Section 25500 et seq.);
 - Carpenter-Presley-Tanner Hazardous Substance Account Act (California Health and Safety Code Section 25300 et seq.); and
 - Emergency Planning and Community Right to Know Act (42 U.S.C. Section 11001 et seq.); and
- Miscellaneous:
 - County Lobbyist Ordinance;
 - County Defaulted Property Tax Reduction Ordinance.
 - Civil Rights Act of 1964 (Subchapter VI of Chapter 21 of Title 42);
 - AB 939;
 - SB 1383; and
 - AB 1826.

Reference to Applicable Law includes future amendments and supplements to or replacement, restatement, or recodification thereof.

Assembly Bill (AB) 939 means the California Integrated Waste Management Act of 1989, California Public Resources Code Section 40000 et seq., and regulations thereunder.

Authorized Exclusive Commercial Franchise Waste Hauler means a waste hauler that has signed a Commercial Franchise agreement with COUNTY and is currently in good standing.

Authorized Residential Franchise Waste Hauler means a waste hauler that has signed a Residential Franchise agreement with COUNTY and is currently in good standing.

Award Date means the date County of Los Angeles Board of Supervisors approves the CONTRACT.

Basic Service Rates means the monthly charges that CONTRACTOR bills a Customer for providing Collection Services, without additional optional services.

Best Efforts mean serious and sizeable efforts that a respectable Person would take in the same (or similar) circumstances, using principles of impartiality of fairness. It will be presumed that the Person intends to meet its obligations in honesty and good faith.

Bilingual means in the languages of English and Spanish or other languages that may be required under Article 4 of SB 1383 or other laws.

Board of Supervisors means the Board of Supervisors of County of Los Angeles.

Breach means CONTRACTOR's failure to fully and timely meet one or more Performance Obligations.

Bulky Item means any large item of Solid Waste that will not fit into an empty Container that can be safely lifted by two individuals using a dolly that has been placed at the Set-Out Site for Collection by CONTRACTOR. A Bulky Item includes, but is not limited to the following:

- Discarded furniture (such as chairs, sofas, mattresses, and rugs);
- Large Appliances (such as refrigerators, ranges, washers, dryers, water heaters, dishwashers, and other similar items commonly known as "white goods");
- Up to two tires from passenger cars or pickup trucks;
- Special Recyclable/Reusable Items (such as textiles, wood/lumber and E-waste), as defined in item F1d of Exhibit 3A1.

Bulky Items excludes items such as:

- Large truck tires;
- Unpermitted Waste;
- Construction and Demolition Debris;
- Piles of debris.

Calendar Year means the months beginning January 1 and ending December 31.

Cart means a wheeled plastic Container provided by CONTRACTOR for storage of Solid Waste pending Collection, which is Collected (semi) by automated Vehicle. Examples include 32, 64, and 96-gallon plastic Containers. Carts are often referred to as barrels. Cart sizes vary depending on the manufacturer, and any reference to Cart sizes in this Agreement are approximations.

CCR means California Code of Regulations.

CERCLA means the Comprehensive Environmental Response, Compensation, and Liability Act of 1982 (42 U.S.C. Section 9601 et seq.).

Change in Law means the occurrence of any event or change in Applicable Law as follows:

- The adoption, promulgation, modification, or change in Applicable Law or in judicial or administrative interpretation thereof occurring after the Execution Date other than laws with respect to taxes based on or measured by net income, or any unincorporated business, payroll, franchise taxes levied by any tax board (other than the Franchise Fees levied by COUNTY) or employment taxes;
- Any order or judgment of any Federal, State, or local court or Regulatory Agency issued after the Execution Date if:
 - That order or judgment is not also the result of the willful misconduct or negligent action or inaction of the Party relying thereon or of any third-Party for whom the Party relying thereon is directly responsible; and
 - The Party relying thereon, unless excused in writing from so doing by the other Party, will make or have made, or will cause or have caused to be made, Reasonable Business Efforts to contest that order or judgment (it being understood that the contesting in good faith of that an order or judgment will not constitute or be construed as a willful misconduct or negligent action of that Party);
- The imposition by a Regulatory Agency of any new or different material conditions about the issuance, renewal, or modification of any Permit after the Execution Date; or
- The failure of a Regulatory Agency to issue or renew, or delay in the issuance or renewal of, or the suspension, interruption, or termination of, any Permit after the Execution Date; if the failure to issue or the suspension or termination of any Permit is not the result of the willful misconduct or negligent action or inaction of the Party relying thereon or any third-Party for whom the Party relying thereon is directly responsible.

Collection Services means all Performance Obligations to Collect Solid Waste at County Commercial Franchise Customer Premises as prescribed in Exhibit 3A1.

Collect, Collection, or Collecting means Solid Waste pickup(s) made by CONTRACTOR required by and in accordance with this CONTRACT.

Commencement Date means the date defined in Item A of Section 2 and is the date Collection Service begins.

Commercial means related to a Person or thing that is not Residential or Multifamily.

Commercial Business means any commercial enterprise or non-profit organization, whether organized as a sole proprietorship, firm, partnership, corporation, non-profit corporation, limited liability company, limited partnership, or business association. The term Commercial Business includes enterprises such as shopping centers and strip malls that lease space to other Commercial Businesses, as well as the Commercial Businesses that lease such space. The term Commercial Business does not include a Residence but

does include a commercial enterprise or non-profit organization that is operated from within a Residence.

Commercial Edible Food Generators includes Tier One Commercial Edible Food Generators and Tier Two Commercial Edible Food Generators, or as otherwise defined in 14 CCR Section 18982(a)(7). For the purposes of this definition, Food Recovery Organizations and Food Recovery Services are not Commercial Edible Food Generators, or as otherwise specified by 14 CCR Section 18982(a)(7).

Compostable Plastics means plastic materials that meet the ASTM D6400 standard for compostability as described in 14 CCR Section 18984.1(a)(1)(A) or 18984.2(a)(1)(C).

Compost means a mixture of decayed or decaying Organic matter (such as leaves and grass) used to amend or fertilize soil.

Construction and Demolition (C&D) Debris means material, other than Unpermitted Waste, including hazardous waste, radioactive waste, or medical waste, that is generated by or results from construction or demolition-related activities including, but not limited to: construction, deconstruction, demolition, excavation, land clearing, landscaping, reconstruction, remodeling, renovation, repair, and site clean-up, as defined in County Code 20.87.030. C&D debris includes, but is not limited to: asphalt, concrete, brick, lumber, gypsum wallboard, cardboard and other associated packaging, roofing material, ceramic tile, carpeting, plastic pipe, steel, rock, soil, gravel, tree stumps, and other vegetative matter. In this Contract, C&D debris is not a type of solid waste.

Container means any Cart, Dumpster, or Roll-Off used to provide Collection Service. It is a receptacle for Organic Waste, Recyclables, and/or Refuse that is located on the site where such material is generated and is intended for the storage of such material before it is collected, Hauled and/or Managed On-Site. The term Container includes stand-alone receptacles as well as sections of divided receptacles or plastic bags that are used to separate different types of material.

Container Contaminants means material that has been deposited into any Container that is not the type of material for which the Container is designated, in contravention of the requirements of an applicable Organic Waste Collection Service.

CONTRACT means this CONTRACT, including all exhibits and other attachments, which exhibits and other attachments are incorporated in this CONTRACT by reference.

Contract Services means all CONTRACTOR's obligations and Services provided to the under this CONTRACT.

Contract Year means each 12-month period commencing on the first day of the month in which CONTRACTOR Collects Solid Waste from any Occupant.

CONTRACTOR means the Person executing this CONTRACT and any assignee of CONTRACTOR consented to by COUNTY in accordance with Section 19.

CONTRACTOR includes CONTRACTOR's Subcontractors unless explicitly provided otherwise. References to all CONTRACTOR's actions and Performance Obligations under this CONTRACT include reference to Subcontractors' actions under this CONTRACT, as applicable, without specifying in each instance that CONTRACTOR shall directly take those actions itself, or cause its Subcontractors to take those actions on CONTRACTOR's behalf.

Contractor Default is described in Part 3 of Exhibit 5.

Contractor Documentation means documentation in Exhibit 17.

Contractor Manager means any of the following:

- The authorized representative of CONTRACTOR named in Contractor Documentation in Exhibit 17.

Contractor Office Hours means 8:00 a.m. to 5:00 p.m. Monday through Friday, except Holidays.

Contractor's Related Parties means CONTRACTOR's partners, officers, directors, agents, employees, Subcontractors, consultants, licensees, invitees, and Affiliates.

Conversion Technology (CT) means an array of technologies capable of converting residual Solid Waste into useful products, including fuels, chemicals, and other sources of clean energy.

COUNTY means the government entity known as County of Los Angeles.

County Commercial Franchise Customers means as specified in item A1 of Exhibit 3A1.

County Business Day means any day on which Los Angeles County Public Works is open to do business with the public.

County Code means the Los Angeles County Code.

County Defaulted Property Tax Reduction Program or **County Defaulted Property Tax Reduction Ordinance** means County Code Chapter 2.206.

COUNTY Lobbyist Ordinance means County Code Chapter 2.160.

County's Reimbursement Costs means Direct Costs of COUNTY plus 35 percent thereof.

County's Related Parties means political subdivisions, agencies, entities, or organizations for which the Board of Supervisors is the governing body, their agents, officers, and employees, elected officials, assigns, volunteers, and special districts

(including Garbage Disposal Districts) and each one of them. County's Related Parties are third-Party beneficiaries of provisions in this CONTRACT that reference them.

CPI means the Consumer Price Index ("CPI"), for Trash and Garbage Collection (CUUR0000SEHG02), U.S. City average, published by the United States Department of Labor, Bureau of Labor Statistics at <https://beta.bls.gov/dataViewer/view/timeseries/CUUR0000SEHG02>

Criminal Activity means any of the following:

- Fraud or criminal felony offenses relating to obtaining, attempting to obtain, procuring, or performing a public or private CONTRACT related to Recyclables, Green Waste or MSW Management Services of any kind (including Collection, hauling, Transfer, Processing, Composting, or Disposal), including this CONTRACT;
- Bribery or attempting to bribe a public officer or employee of a local, State, or Federal agency;
- Embezzlement, extortion, racketeering, false claims, false statements, forgery, falsification or destruction of Records, obstruction of justice, knowingly receiving stolen property, theft, or misprision (failure to disclose) of a felony;
- Unlawful Disposal of hazardous, designated, or other waste; or
- Violation of securities laws or antitrust laws, including laws relating to price-fixing, bid rigging and sales and market allocation, and of unfair and anticompetitive trade practice laws, including with respect to inflation of Solid Waste Collection, hauling or Disposal fees.

Customer means a Person who pays for Collection Services provided by CONTRACTOR.

Customer Bill of Rights means the Customer Bill of Rights included in Contractor Documentation in Exhibit 17.

Customer Subscription Order means Customer Subscription Order Form included in Contractor Documentation in Exhibit 17.

Customer Extra Services Fees means the amounts listed as "Extra Services Fees" found in Attachment 7-2 of Exhibit 7.

Customer Service Rates means the amount that CONTRACTOR bills Customers for providing Collection Services.

Customer Service Rates Schedule is found in Attachment 7-2 of Exhibit 7.

Day means calendar day, whether capitalized or lower case.

Debarment or **Debar** has the meaning assigned in County Code Section 2.202.020.

Direct Costs means the sum of the following but excludes profit or return on investment:

- Payroll costs directly related to the performance, management, or supervision of any obligation under this CONTRACT, or exercise of any right, comprised of compensation and fringe benefits, including vacation, sick leave, Holidays, retirement, Worker's Compensation insurance, Federal and State unemployment taxes and all medical and health insurance benefits, plus;
- The costs of materials, services, direct rental costs, and supplies, plus;
- Travel and subsistence costs, plus;
- The reasonable costs of any payments to Subcontractors (with respect to CONTRACTOR) or contractors (with respect to COUNTY) or third Parties necessary to and about Performance Obligations, plus;
- Any other cost or expense which is directly or normally associated with the task performed; which is substantiated by:
 - A certificate signed by the principal financial officer of CONTRACTOR or the authorized representative of COUNTY setting forth the amount of that cost and the reason that cost is properly chargeable to COUNTY or CONTRACTOR and stating that the cost is a competitive price, if there are competitive prices, secured in an arm's length transaction for the service or materials supplied; and
 - If COUNTY or CONTRACTOR requests additional backup documentation as may be available to reasonably substantiate any Direct Costs, including invoices from suppliers, Subcontractors, and contractors.

Director means COUNTY Director of Public Works or his or her authorized representative, including the authorized representative named in Attachment 5-8G.

Director's Office Hours means hours that Director is open to do business as indicated in Attachment 5-8G.

Disabled means Occupants who suffer from a disability as evidenced by a letter from their medical physician.

Disposal or **Dispose** means Disposal, as defined in California Public Resources Code Section 40192, at a Solid Waste Facility of Refuse that CONTRACTOR has Collected.

District means Garbage Disposal District.

Diversion or **Divert** means activities that reduce or eliminate the amount of Solid Waste from Disposal for the purposes of Division 13 of the California Public Resources Code, including Article 1 (commencing with Section 41780).

Diversion Goal means the current State law requirement of 50 percent, the State goal of 75 percent Diversion by 2025, and future COUNTY goals including the Roadmap to a Sustainable Waste Management Future adopted by the Board of Supervisors on April 22, 2014. The Roadmap goals are 80 percent Diversion from landfills by 2025, 90 percent Diversion from landfills by 2035, and 95 percent or more Diversion from landfills by 2045,

as calculated by Director using Director's methodology. State and COUNTY goals are subject to change.

Dumpster means a container for storage of Solid Waste that is usually Collected with front end loading Vehicles, such as those having a 1- to 8-cubic yard capacity, commonly referred to as a Dumpster. Dumpsters are also often referred to as bins.

Edible Food has the meaning set forth in Title 14, section 18982(a)(18) of the California Code of Regulations and means food that is appropriate for human consumption and that meets the food safety requirements of the California Retail Food Code. For the purposes of this Chapter, Edible Food is not Solid Waste if it is Recovered and not discarded.

Elderly means a Person age 62 or older as evidenced by a driver's license or other document issued by a governmental entity.

E-waste means waste that is powered by batteries or electricity, such as computers, telephones, stereo equipment, DVD players/recorders, mp3 players, televisions, and calculators.

Execution Date means the date this CONTRACT is signed by both COUNTY and CONTRACTOR.

Expiration Date means the date this CONTRACT expires as provided in accordance with item A of Section 2.

Fiscal Year means the 12-month period beginning July 1st and ending the following June 30th.

Franchise Fee means the fee described in item D of Section 1.

Garbage Disposal District means a district created under County Code Chapter 20.90 and referred to as COUNTY in this CONTRACT.

Goods or Services means goods or services used in providing Contract Services, including labor; leases; subleases; equipment; supplies; capital; insurance, bonds, or other performance security if the insurer, surety, or other provider is an Affiliate or a captive of CONTRACTOR or any Affiliate; and legal, risk management, general, and administrative services.

Green Waste means Solid Waste comprised of leaves, grass clippings, brush, branches, nonhazardous wood waste, and other forms of Organic matter generated from landscapes and gardens and separated from other forms of Solid Waste, including Christmas Trees and bushes, but excluding:

- Stumps or branches exceeding four inches in diameter or four feet in length;
- Yucca or palm fronds, unless CONTRACTOR can Divert those excluded materials in non-Composting processes; and

- Other Director-approved items listed in the Terms and Conditions.

Gross Receipts means fees, charges, and other compensation that CONTRACTOR or Contractor's Related Parties receive directly or indirectly from Customers and Occupants about Collection Services before any deduction for costs or expenses such as the Franchise Fee. Gross Receipts does not mean fees, charges, and other compensation that CONTRACTOR or Contractor's Related Parties receive about the sale of Recyclables.

High Diversion Organic Waste Processing Facility means a High Diversion Organic Waste Processing Facility as defined in 14 CCR Section 18982(a)(33). Per SB 1383 Regulations (14 CCR Section 18982(a)(33)), the High Diversion Processing facility is a facility that is in compliance with the reporting requirements of 14 CCR Section 18815.5(d) and meets or exceeds an annual average mixed waste organic content recovery rate of 50 percent (50%) between January 1, 2022 and December 31, 2024, and 75 percent (75%) after January 1, 2025 as calculated pursuant to 14 CCR Section 18815.5(e) for Organic Waste received from the Mixed Waste.

Holidays means January 1, Memorial Day, 4th of July, Labor Day, Thanksgiving, and December 25 and any other Holidays designated by COUNTY in Notice to CONTRACTOR.

HOA means Homeowner Association.

Including or **Include** or variations thereof, when used in this CONTRACT, means "including without limitation," "including, but not limited to," and "including, at a minimum."

Indemnities or **Indemnification** means all defenses, Indemnities, and releases under this CONTRACT, including under Part 2A of Exhibit 5 (generally), and with respect to the Immigration Reform and Control Act and Cal/OSHA (specifically).

Liabilities mean any of the following:

- Liabilities;
- Lawsuits;
- Claims;
- Complaints;
- Cause of actions;
- Citations;
- Investigations;
- Judgments;
- Demands;
- Cleanup orders;
- Damages (whether in contract or tort, including:
 - Personal injury to or death of, at any time, CONTRACTOR's employees, Subcontractors, COUNTY employees or third Parties; and

- Property damage of CONTRACTOR, Subcontractors, COUNTY employees or third Parties);
- Costs and expenses, (including all costs and expenses of litigation, mediation or arbitration, attorneys' fees, whether COUNTY's or CONTRACTOR's staff attorneys or outside attorneys, and court costs);
- Losses;
- Fines;
- Penalties; and
- Other detriments of every nature and description whatsoever, whether under State of California or Federal law.

Liquidated Damages means the amounts due by CONTRACTOR for failure to meet specific quantifiable standards of performance as described in Exhibit 12-D2 Liquidated Damages.

Local Enforcement Agency means the enforcement agency defined in County Code Section 20.56.030.

Management of Organic Waste On-Site or "Manage On-Site" Management of Organic Waste On-Site, or Manage On-Site when used in reference to Organic Waste, means to conduct an operation that converts Organic Waste into a useful product, on the same property or site where the Organic Waste is generated.

Manure means Solid Waste comprised of horse dung or excrement and may include straw or other absorbent.

Maximum Rate Adjustment is described in Section A3 of Exhibit 7.

Micro-Hauler means a Hauler that collects Organic Waste from Organic Waste generators, in limited quantities as determined by the Director, and transports such Organic Waste to a Community Composting facility. A Micro-Hauler must enter into a contract or Franchise with the County in order to be authorized to collect Organic Waste from Organic Waste Generators.

Micro-Haulers are not to provide Organic service to accounts with large Organic service levels. For the purposes of this section, a large Organic service level is equal to or more than one 64-gallon Container Collected weekly. Micro-haulers are not to exceed Collection threshold of 5 tons of Organic Waste per month per Service Area.

Mixed Waste means any type of Solid Waste that contains Organic Waste material must be transported to a High Diversion Organic Waste Processing Facility. If the Solid Waste only contains Recyclables and no Organic Waste, then it shall be transported to a materials recovery facility that recovers Recyclable materials that is mixed with Refuse.

Minimum Default Collection Service includes a minimum base rate for the level of service for Refuse which is agreed upon by the Customer and CONTRACTOR and shall be charged accordingly to the rates set forth in Exhibit 7, Attachment 7-2 (Service Rates).

The Refuse rate will automatically include a subscription of a 64-gallon Cart of weekly Organic Waste Collection and a 96-gallon Cart of weekly Recyclables Collection Service per Customer, both at no additional charge unless the Customer requires service beyond the minimum.

Mulch means Organic materials commonly used for Mulch including wood chips, ground up landscape trimmings, shredded bark, coarse Compost material, and straw.

Multifamily means Person or thing related to (1) dwellings with five or more attached dwelling units (such as apartments), each with separate cooking and bathing facilities, (2) townhouses, and (3) condominiums, whether attached or detached.

Multifamily Premises means Premises containing a Multifamily building.

Municipal Solid Waste (MSW) Management Services means any of the following:

- Collection, transportation, storage, Transfer, or Processing of:
 - Solid Waste; or
 - Unpermitted Waste that is Collected as part of a Collection program for Bulky Items, and E-waste described in Exhibit 3A1 and handled in accordance with Applicable Law (such as tires more than load limits, and certain E-waste); or
- Arranging for Disposal of that Solid Waste or Unpermitted Waste.

Non-Collection Notice means the Notice in the form included in Contractor Documentation in Exhibit 17 in accordance with item A5 of Exhibit 3A1.

Notice (when capitalized) means Notice given in accordance with Part 5F of Exhibit 5.

Occupant means a Person within the Service Area that occupies a Residential, Multifamily or Commercial Premises and receives services from CONTRACTOR.

Office means CONTRACTOR's offices required by item A of Section 6 to be identified in Contractor Documentation in Exhibit 17.

Organic Waste (or Organics) means Solid Waste that contains material originating from living organisms and their metabolic waste products, all in accordance with 14 CCR 18982(a)(46) but excluding Unpermitted Waste.

Organic Waste include:

- Green Waste,
- Food Waste,
- Manure,
- Biosolids, digestate, and sludges
- Clean, untreated wood and lumber

Organic Waste are presumed to be source-separated *unless* they are explicitly described as commingled. “Organic Waste” is synonymous with both of the following:

- “Source Separated Organic Waste” in 14 CCR 18982(a)(69), and
- Recyclables that may be allowed to be collected in the green Container such as paper, cardboard, textiles, carpet, lumber, and wood.

Organic Waste Collection Service means a service for the Collection of Organic Waste by an Authorized Hauler, other than a Micro Hauler, that complies with the requirements of a three-Container Collection Service described in Title 14, Section 18984.1 of the California Code of Regulations, a two-Container Collection Service described in Title 14, Section 18984.2 of the California Code of Regulations, or a single Container service as described in accordance with Title 14, section 18984.3 of the California Code of Regulations.

Organic Waste Processing Facility means:

1. A facility, operation or activity described in Title 14, Section 18983.1(b) of the California Code of Regulations, that Recovers or utilizes Organic Waste in a beneficial manner that does not constitute landfill disposal, including:
 - a. A High Diversion Organic Waste Processing Facility;
 - b. A recycling center as defined in Title 14 of the California Code of Regulations, Section 17402.5(d) or that is listed in Title 14 of the California Code of Regulations, Section 17402.5(c);
 - c. A compostable material handling operation or facility as defined in Title 14 of the California Code of Regulations, Section 17852(a)(12), small composting activity that would otherwise be excluded from that definition by Title 14 of the California Code of Regulations, Section 17855(a)(4), or Community Composting;
 - d. An in-vessel digestion operation or facility as listed in Title 14 of the California Code of Regulations, Section 17896.5 or activities that would otherwise not be subject to the in-vessel digestion requirements pursuant to Title 14 of the California Code of Regulations, Section 17896.6;
 - e. Biomass conversion operation or facility as defined in California Public Resources Code Section 40106;
 - f. An operation that uses Organic Waste as soil amendment for erosion control, revegetation, slope stabilization, or landscaping at a landfill when the material is used in a manner that complies with requirements set forth in Title 14 of the California Code of Regulations, Section 18983.1(b)(5);
 - g. An operation that uses Organic Waste as land application, and that complies with the requirements set forth in Title 14 of the California Code of Regulations, Section 18983.1(b)(6);

- h. An operation that uses Organic Waste as animal feed in accordance with Title 14 of the California Code of Regulations, Section 18983.1(b)(7); and
 - i. Other operations or facilities with processes that process or utilize Organic Waste in a manner that constitutes the reduction of landfill disposal, as determined by CalRecycle in accordance with Title 14, Section 18983.2 of the California Code of Regulations.
2. A Transfer/processing Facility that Recovers Organic Waste for eventual delivery to a facility described in subsection (GG)(1) of County Code, Chapter 20.91-Mandatory Organic Waste Disposal Reduction Ordinance, as long as the Organic Waste has been Source Separated in accordance with Title 14, Sections 18984.1 or 18984.2 of the California Code of Regulations and is not required to be taken to a High Diversion Organic Waste Processing Facility.

Party or Parties means COUNTY and CONTRACTOR, individually and together, respectively.

Performance Obligations means every obligation and liability of CONTRACTOR under this CONTRACT.

Permit means any Federal, State, County, other local, and any other governmental unit Permit, order, license, approval, authorization, consent, or entitlement of whatever kind and however described that Applicable Law requires to be obtained or maintained with respect to the satisfaction of Performance Obligations, as renewed or amended from time to time, including the waste collector Permit issued by the Los Angeles County Department of Public Health.

Person means any individual, firm, association, organization, partnership, corporation, trust, joint venture, State, County, municipality, special purpose district, the United States or any other entity.

Position of Influence means a position of authority or responsibility to directly or indirectly administer, manage, direct, supervise or oversee the Contract Services or this CONTRACT, including the following: (1) serving as director of the board of directors of CONTRACTOR or an Affiliate, (2) serving as an officer of CONTRACTOR or an Affiliate, (3) reviewing or negotiating CONTRACTOR's contracts (including this CONTRACT), (4) providing in-house legal services, and (5) providing insurance or other performance security if the provider is an Affiliate or is a captive of CONTRACTOR or an Affiliate; but excluding the following: (1) monitoring CONTRACTOR's performance, (2) supervising CONTRACTOR's finance and capital budget decisions, and (3) articulating general policies and procedures not related to a Criminal Activity.

Premises means a tract of land located in the Service Area which is safely accessible by Vehicles.

Processing or Process means the controlled separation, recovery, volume reduction, conversion, or Recycling of Solid Waste including, but not limited to, organized, manual, automated, or mechanical sorting, the use of vehicles for spreading of waste for the purpose of recovery, and/or includes the use of conveyor belts, sorting lines, or volume reduction equipment, as defined in 14 CCR Section 17402(a)(20).

Prompt or Promptly means as soon as practicable, but in no event more than two days unless otherwise agreed by Director, Customer, or Occupant.

Property Owner means the owner of real property, as defined in 14 CCR Section 18982(a)(57).

Public Right-of-Way or Right-of-Way includes all the following:

- all land and improvements on that land between the outer edge of a sidewalk (nearest to a private lot) on one side of the street and the outer edge of the sidewalk (nearest to a private lot) on the opposite side of the street, including:
 - sidewalks,
 - and between a sidewalk and street, and
 - median strips in the center of streets.
- Public streets;
- Public alleys, including land wall-to-wall and fence-to-fence, and
- Any other land described by COUNTY to CONTRACTOR.

Quarterly Report is described in item A1 of Section 10.

Rate Adjustments and **Rate Adjustment Example** are both described in Exhibit 7 and Attachment 7-1 Rate Adjustment Example.

RCRA means the Resource Conservation and Recovery Act (42 U.S.C. Section 6901 et seq.).

Reasonable or **Reasonable Business Efforts** means practical actions a sensible person would do in the same (or similar) circumstances using sound judgment and principles of fairness. It will be presumed that the Person intends to meet its obligations in honesty and good faith. It does not mean pursuing every possible action.

Records means documentation relating to Contract Services and other Performance Obligations, including ledgers, books of account, invoices, vouchers, canceled checks, logs, correspondence, computations, files, plans, correspondence, Reports, drawings, designs (other than those respecting facilities or facility operations not involving Collection), data and photographs prepared by or possessed by CONTRACTOR, including the following:

- Customer and Occupant Terms and Conditions and Collection Services information (including Customers and Occupants' names and addresses), billing Records, call logs, route maps, schedules, and correspondence with Customers and Occupants;

- Weight tickets, invoices, bills of lading, and receipts from Solid Waste Facilities for types and amounts of Solid Waste that CONTRACTOR Collects, transports, and delivers to those Solid Waste Facilities;
- Records for AB 939 and other laws, including documentation from Recyclables and Green Waste transporters, shippers, brokers, beneficiaries, remanufacturers, and purchasers or other users of Recyclables and Green Waste; any Reports on Processing of Recyclables or Green Waste residual that Solid Waste Facilities may make to the CalRecycle;
- Vehicle maintenance, driver Permits and driver testing Records;
- Gross revenues and receipts, including Gross Receipts;
- the Franchise Fees paid to COUNTY; and
- Records that may be relevant in the event of an action under CERCLA or similar claims.

Recyclables means Solid Waste that is non-putrescible and that can be Recycled, excluding Unpermitted Waste.

Recyclables includes:

- Bottles, cans, metals, plastics, and glass,
- Paper products,
- Printing and writing paper,

Additional (or deleted) items that Director directs after Notice to CONTRACTOR, without adjustment of Service Rates unless the modification requires Collection Services at the Set-Out Sites separate and distinct from previously Collected Recyclables, subject to item E2 of Exhibit 3A1.

Recyclables are presumed to be Source Separated *unless* they are explicitly described as commingled. Recyclables are synonymous with both of the following:

- "Non-Organic Recyclables" as defined in 14 CCR 18982(a)(43), and 14CCR 17402(a)(26.7),
- Source Separated Recyclables discarded in blue Containers.
- Organic Waste allowed to be Collected in the blue Containers such as: paper, textiles, lumber, carpet and wood.

Recycle or Recycling means the Process of Collecting, sorting, cleansing, treating, and reconstituting materials (including Recyclables and Organic Waste) that would otherwise become Solid Waste and returning them to the economic mainstream in the form of raw material for new, reused, or reconstituted products that meet the quality Standards necessary to be used in the market place. Recycling does not include transformation, as defined in California Public Resources Code Section 40201.

Refuse means Solid Waste that CONTRACTOR does not Divert.

Regulatory Agency means any Federal, State or local governmental agency that regulates Collection and transportation of Solid Waste (including California Department of Transportation, California Department of Motor Vehicles, EDD, U.S. Immigration and Naturalization Services, or other health and safety department thereof; COUNTY; and Local Enforcement Agency applicable to Contract Services).

Report means Quarterly Report, Annual Report and any AB 939, SB1383, or other report CONTRACTOR is required to submit in accordance with this CONTRACT and must be satisfactory to Director.

Residential means Person or thing related to detached, single-family homes or duplexes, other than condominiums or townhouses. Residential also includes multifamily Premises of 4 Units or less.

Residential Premises means Premises containing a Residential building, such as a detached, single-family home or a duplex.

RNG or Renewable Natural Gas means gas derived from Organic Waste that has been diverted from a Landfill and Processed at an in-vessel digestion facility that is permitted or otherwise authorized by 14 CCR to recover Organic Waste, as defined in 14 CCR Section 18982(a)(62).

Roll-offs “roll-off box” means any open-topped rectangular Container for storage, Collection, and transport of Solid Waste that are rolled on and off flatbed Collection Vehicles via winches or reeving cylinders (hooks), sometimes referred to as debris boxes.

Scout Service means using a small truck that can retrieve Containers from hard-to-reach places, such as a narrow street or small enclosures, and are pulled out to an accessible area for the automated Collection Vehicles to service it. Once the Container is emptied by the automated Collection Vehicle, the Container is returned back to its Set-Out Site location.

Self-Haul or Self-Hauler means: (1) for a Person to transport Recyclables, Organic Waste, or Refuse that such Person has generated, or that has been generated on property owned or occupied by such Person, to another location, or to a separate destination owned and operated by such Person, without contracting with or utilizing a third-party; and (2) for a Person to remove Refuse, Organic Waste, or Recyclables generated as a result of gardening, landscaping or contracting services performed by such Person for a third party, when such removal of material is ancillary to the gardening, landscaping or contracting services, without subcontracting for services or equipment.

Senate Bill (SB) 1383 means Senate Bill 1383 of 2016 approved by the Governor on September 19, 2016, which added Sections 39730.5, 39730.6, 39730.7, and 39730.8 to the Health and Safety Code, and added Chapter 13.1 (commencing with Section 42652) to Part 3 of Division 30 of the Public Resources Code, establishing methane emissions reduction targets in a statewide effort to reduce emissions of short-lived climate pollutants as amended, supplemented, superseded, and replaced from time to time.

Senate Bill (SB) 1383 Regulations or SB 1383 Regulatory refers to the Short-Lived Climate Pollutants (SLCP): Organic Waste Reductions regulations developed by CalRecycle and adopted in 2020 that created Chapter 12 of 14 CCR, Division 7 and amended portions of regulations of 14 CCR and 27 CCR.

Service Area means the area mentioned in the title of this CONTRACT, as described in item A1 of Section 16.

Service Assets means all property of CONTRACTOR used directly or indirectly in performing Contract Services, including Vehicles, Containers, maintenance equipment and facilities, and administrative equipment and software, both tangible and intangible (such as facility leases or equipment installment purchase contracts).

Service Day means Collection Services for Commercial Customers is only permitted Monday through Saturday, except following a Holiday. For Residential Customers, Collection Services is permitted any day Monday through Friday, excluding Holidays.

Service Rates means Customer Service Rates as listed in Attachments 7-2 of Exhibit 7

Service Rates Schedule means all the rates listed in Attachments 7-2 of Exhibit 7.

Service Specifications means Performance Obligations prescribed in Exhibit 3A1.

Service Standards means each obligation of CONTRACTOR prescribed in Section 4.

Set-Out Site means the location where the Solid Waste is temporarily placed for Collection as mutually agreed upon by CONTRACTOR and Occupant.

Sharps means any item having corners, edges, or projections capable of cutting or piercing the skin to deliver injections or for medical purposes, such as needles (hypodermic, pen or intravenous), needles with syringes, needles from vacutainers, needles with attached tubing, and lancets.

Sharps Containers means Container approved by COUNTY for discard of Sharps.

Solid Waste means Solid Waste as defined in California Public Resources Code Section 40191, excludes Unpermitted Waste but includes all the following:

- Recyclables,
- Refuse,
- E-waste,
- Organic Waste (including green and food waste),
- Manure

Solid Waste Facility means the facility as defined in California Public Resources Code Section 40194 (and any other types of facilities named by Director) and designated by CONTRACTOR in Contractor Documentation in Exhibit 17.

Source Separated means to separate different types of Solid Waste such as Organic Waste and Recyclables and to place such waste in the correct Container. Source Separation is not required for Customers that utilize a one-Container system in which the combined Solid Waste is transported and delivered to a High Diversion Organic Waste Processing Facility.

Standards means the criterion for excellent Solid Waste management established by the Solid Waste Collection industry; which shall be provided in a thorough and professional manner so that all Customers are provided at all times with reliable, courteous and high-quality Solid Waste handling services. To determine what is "professional" COUNTY may consider policies, standards, recommendations and other statements from associations whose members handle Solid Waste, such as the Solid Waste Association of North American (SWANA), the National Waste and Recycling Association, Association of County Engineers.

Subcontractor means any Person that provides Goods or Services related to Collection, transportation or storage of Solid Waste or related to Service Assets, including their operation, maintenance, and repair, to or on behalf of CONTRACTOR whether pursuant to any arrangement, formal or informal, written or merely in practice. Subcontractor does not include a Person that provides Goods or Services related to Processing, Diversion, or Disposal, nor the manufacturer that provides equipment.

Term means the period beginning on the Execution Date and ending on the Expiration Date and is also defined in item A of Section 2.

Terms and Conditions means the CONTRACT details mailed to Customers and Occupants.

Ton or Tonnage means a short ton of 2,000 pounds avoirdupois.

Transfer is defined in Part 4 of Exhibit 5.

Uncontrollable Circumstances means any of the following events:

- Riots, war, or emergency affecting the County and/or the Country declared by the President of the United States, Congress of the United States, the Governor of California, or the Board of Supervisors;
- Sabotage, civil disturbance, insurrection, explosion;
- Natural disasters such as floods, earthquakes, landslides, and fires;
- Pandemic, epidemics, strikes, lockouts, and other labor disturbances; or
- Other catastrophic events that are beyond the reasonable control of CONTRACTOR despite CONTRACTOR's exercise of due diligence, excluding:
 - The financial inability of CONTRACTOR to satisfy its Performance Obligations, or

- Failure of CONTRACTOR to obtain any necessary Permits or the right to use the facilities of any public entity.

Universal Waste means hazardous waste that the California Department of Toxic Substances Control considers Universal Waste, including materials listed in 22 CCR 66261.9, such as batteries, thermostats, lamps, cathode ray tubes, computers, telephones, answering machines, radios, stereo equipment, tape players/recorders, phonographs, video cassette players/recorders, compact disc players/recorders, calculators, some appliances, aerosol cans and certain mercury-containing devices.

Unpermitted Waste means

- Materials that are not Solid Waste such as Universal Waste, household hazardous waste and other hazardous waste, unauthorized medical waste, radioactive waste;
- Waste tires more than the limitations prescribed in 14 CCR 17355(b) or reduced in volume as required in 14 CCR 17355(A);
- Any other materials that cannot be Disposed of in class II sanitary landfills described in 27 CCR 20250.

Unpermitted Waste Screening Protocol means the protocol prescribed in Item A of Section 13 and included in Contractor Documentation in Exhibit 17.

Vehicle means any truck used by CONTRACTOR to provide Contract Services.

Violation of Applicable Law means any noncompliance with Applicable Law as evidenced by Notice, assessment, or determination of any Regulatory Agency to CONTRACTOR, whether a fine or penalty is included, assessed, levied, or attached.

Weighted Customer Service Rate Adjustment Percentage means sum of the adjustments due to changes in the CPI, for Trash and Garbage Collection (CUUR0000SEHG02), U.S. City average, as published by the United States Department of Labor, Bureau of Labor Statistics at <https://beta.bls.gov/dataViewer/view/timeseries/CUUR0000SEHG02>.

EXHIBIT 7 – Rate Adjustments

A. Service Rates Schedule

CONTRACTOR shall charge Service Rates (Customer Service Rates) in amounts less than or equal to the Service Rates set forth in the Service Rates Schedule in Attachment 7-2 of this Exhibit.

1. Time, Conditions, Changes

a. *Annual Adjustments*

(1) Annual CPI Calculation:

Beginning at least 6 months after the Commencement Date, Director will adjust the Service Rates each July 1 based on the percentage change in the average annual published CPI, for Trash and Garbage Collection (CUUR0000SEHG02), U.S. City average, as published by the United States Department of Labor, Bureau of Labor Statistics. The annual change is a comparison of the average monthly rate for the two previous Calendar Years.

A minimum of 6 months must elapse between Commencement Date and July 1 of the current year. The CPI component of the Service Rate will be the percent change, if any, between the following:

- The monthly average CPI during the 12-month period commencing March 1 of the previous year to the last day of February of the current year, and
- The monthly average CPI during the 12-month period commencing March 1 of the prior previous year to the last day of February of the previous year.

For example, a contract that started April 1, 2021, will not be eligible for a Rate Adjustment for CPI on July 1, 2021. On July 1, 2022, the Rate Adjustment would compare March 1, 2021 through February 28, 2022, to March 1, 2020 through February 28, 2021.

The index to be used is the Consumer Price Index for Trash and Garbage Collection (CUUR0000SEHG02), U.S. City average, as published by the United States Department of Labor, Bureau of Labor Statistics at <https://beta.bls.gov/dataViewer/view/timeseries/CUUR0000SEHG02>.

b. Adjustments at Any Time

If CONTRACTOR requests Director by Notice or Director Notifies CONTRACTOR at any time, following agreement with CONTRACTOR, the Director may adjust the Service Rates in either of the following events, subject to changes in Refuse Disposal or Organic Waste Diversion in subsection A3, and limitations in A5:

(1) Changes in Law

Change in CONTRACTOR's Direct Costs of providing Contract Services due to Changes in Law. Any adjustment in the Service Rate due to a Change in Law by the State is not included in the Maximum Rate Adjustment in subsection 3.

(2) Changes in Scope of Service

CONTRACTOR's Direct Costs of providing Contract Services due to changes in Contract Services or Standards.

(3) Extraordinary Circumstances

Change in CONTRACTOR's Direct Costs of providing Contract Services due to unforeseeable events.

c. No Adjustment

Service Rates will not be adjusted:

- During any of the six possible one-month extensions under item A3 of Section 2.
- If there are any uncured Breaches.
- For any slight increase or decrease in Customers due to inaccuracies in Customer data and Service Area boundaries.

2. Rounding

All calculations are rounded to the nearest 1/100th decimal place (for example, 10.9656 percent to 10.97 percent, or 10.9637 percent to 10.96). The decimal 5 is rounded up (for example, 10.965 percent to 10.97 percent). Adjustments in Service Rates are rounded to the nearest penny (for example, \$25.34).

3. Maximum Rate Adjustment

Adjustments to the Service Rates cannot exceed the percentages in the following table, except for changes due to acts of the State in item A1b(1) of this exhibit:

| Contract Period (on July 1)* | Maximum Adjustment** |
|--|----------------------|
| Years 0 to 0.5 (Less than 6 months from Commencement Date to July 1) | 0 percent |
| Years 0.5 to 10 (July 1 to the scheduled Termination Date under Section 2) | 5 percent |
| 3-Year / Extension #1, if any (July 1 of any first 3-year extension to June 30 on the extended Termination Date) | 5 percent |
| 3-Year / Extension #2, if any (July 1 of any 3-year extension to June 30 further extended Termination Date) | 5 percent |
| 3-Year / Extension #3, if any (July 1 of any 3-year extension to June 30 further extended Termination Date) | 5 percent |
| Six 1-month extensions, if any | No Change |
| Any time (Changes in direct costs due to Change in Law by the State) | Actual Direct Costs |

* Rate Adjustments due to Changes in Laws or Contract Services under subsection A1 above may be implemented at any time during the Term.

** Any change in Service Rates for direct costs due to Changes in Law promulgated by the State in item A1b(1) of this exhibit are not included in the percentage calculations of the Maximum Cumulative Service Rate Adjustment. They are added to the percentage calculations.

For example, during the first ten years of the CONTRACT, the Service Rate could increase 35 percent plus an additional amount due to an increase of \$4 per Ton on the State-mandated Disposal fee.

4. Customer 30-Day Notice

CONTRACTOR shall provide all Customers a minimum of 30-days written Notice of the implementation of changes in any Customer Service Rates.

5. Adjustment Limitations

No adjustment will be effective until Notice thereof has been provided by COUNTY to the Board of Supervisors.

Service Rates will be adjusted only if there are no uncured Breaches.

If CONTRACTOR and Director fail to reach an agreement to adjust the Service Rates because of Changes in Law or changes in Contract Services or Standards described below, COUNTY will have the option to not adjust the rate for changes in law, changes in scope of service, or extraordinary circumstances for the upcoming Fiscal Year.

6. Services Eligible for Adjustment

a. Customer Service Rates (CPI)

b. Customer Extra Services Fees (CPI)

B. Discontinued Indices

If a price or index is discontinued on the date of adjustment, the last available price or index for the required period (such as Calendar Year or another 12-month period) will be used, or other index as determined by Director.

ATTACHMENT 7-1 – Rate Adjustment Example

Example assumes the following:

- Contract started 4/1/21
 - First Calendar Year of service is only 9 months
 - Rate adjustment was not eligible 7/1/21
- Rate adjustment being calculated is for 7/1/22

A. Annual increase or decrease in CPI

Step 1: Calculate percentage change in indices.

| Table A—Adjustment Due to Change in CPI | | |
|---|-----------------------|--------|
| Calculate percent change in CPI, Garbage and Trash Collection (1) (12-month average) | 03/01/19-02/29/20 (A) | 484.59 |
| | 03/01/20-02/28/21 (B) | 502.41 |
| | Percent change (C) | 3.68% |

Step 2: Apply percentage change to rates.

| Example Categories | Rate | (D) Example Customer Rate (2) | (E) Percentage Change in Index (from Row C above) | (F) Rate Increase or Decrease (Column D x Column E) | (G) Adjusted Rate (Column D + Column F) |
|---|------|----------------------------------|--|--|--|
| Commercial- Refuse 3 CY 1x week | | \$90.00 | 3.68% | \$3.31 | \$93.31 |
| Commercial- Organic Waste - 64-Gallon 2x week | | \$81.03 | 3.68% | \$2.98 | \$84.01 |
| Pad Lock | | \$15.00 | 3.68% | \$0.55 | \$15.55 |
| Multifamily- 1 Container for Trash & Organics 3 CY 1 x week | | \$105.00 | 3.68% | \$3.86 | \$108.86 |

(1) Consumer Price Index Consumer Price Index (CUUR0000SEHG02) for All Urban Consumers, garbage and trash collection – U.S. city average, not seasonally adjusted, as published by the United States Department of Labor, Bureau of Labor Statistics. The CPI component of the Service Rates will be the percent change, if any, between the following:

- The monthly average CPI during the 12-month period commencing March 1 of the previous year to the last day of February of the current year, and
- The monthly average CPI during the 12-month period commencing March 1 of the prior previous year to the last day of February of the previous year.

(2) Example rates listed. Adjustment applies to all rates.

ATTACHMENT 7-2- SERVICE RATES

- A. Table 1- Commercial Rates**
- B. Table 2- Multifamily Rates**
- C. Table 3- Residential Rates**
- D. Table 4- Single Pass Collection**
- E. Table 5- Extra Services Fees to Customer**
- F. Table 6- Other Additional Services Rates**

**FORM PW-2.5.1 Schedule of Prices
DISPOSAL INC.**

Proposer Name: WARE

Exclusive Commercial Franchise Services

Service Area: San Gabriel Valley West

The undersigned Proposer offers to perform the work described in the Request for Proposals (RFP) for the following price(s). The Proposer rate(s) (hourly, monthly, etc.) shall include all administrative costs, franchise fees, labor, supervision, overtime, materials, transportation, taxes, equipment, and supplies unless stated otherwise in the RFP. The Proposer understands and agrees that the quantities set forth in the Schedule of Prices by the County are only estimates are based on current hauler submittals. Any unit prices quoted by the Proposer in this Schedule of Prices will apply to the actual quantities of work. The Proposer may use the estimates to develop its cost and rate proposal. The Proposer understands and agrees that each of the Service Areas have different Customer counts. County makes no representation or warranties of any kind, expressed or implied, as to the accuracy of the information set forth in the Schedule of Prices. County will not be liable for any damages or loss of any nature, including, but not limited to, lost profits, resulting from the estimates provided by the County. Proposer agrees to indemnify and hold the County harmless with respect to any issues, disputes, claims, lawsuits resulting from the estimates provided by the County in this solicitation, and in particular, as set forth in the Schedule of Prices. It is the responsibility of the proposer to undertake, at its sole cost, any verification of any and all information necessary for the preparation and submittal of a response to this RFP.

It is the County's sole discretion to select the collection method for each Service Area after receipt of all proposals. The County's selected collection method may not be the lowest cost collection method. The County may consider factors including but not limited to, cost per cubic yard, readiness to implement, regulatory compliance, and waste diversion potential, when deciding upon a collection method for each Service Area.

Instructions: Proposer shall enter proposed monthly rates in the blue boxes below and the discounted rate for Customers who have a waiver/exemption for Organic Waste Collection Services in the yellow box below. Proposer must submit a proposal/bid for each collection method: Three-Container, Two-Container and One-Container collection methods. Failure to do so may result in the proposal/bid being rejected as nonresponsive. All proposers should include the 14% franchise fee in their proposed rates. Proposers shall not change the numbers in Column D- Estimated No. of Collections per Week. Column E will autocalculate the Proposed Annual Amount for each service. The Proposed Total Annual Amounts for Collection Services of the County selected collection method will be used for the evaluation evaluated. Proposer is responsible for ensuring accuracy of calculations.

Commercial Collection Services (Three-Container)

Note: The following rates apply to Commercial Customers. The Minimum Default Collection Service rate includes a minimum base rate for Refuse, Organic Waste, and Recyclables Collection Services. The minimum base rate for Refuse includes the equivalent of 64 gallons of weekly Organic Waste and 96 gallons of weekly Recycling Collection Service per Customer, both at no additional charge.

Recycling rates shall be no more than half of the Refuse rates and Organic Waste rates shall be no greater than the Refuse rates.

Disposal Facility Name: PUENTE HILLS MRF Rate (Per Ton): \$69.92

Backup Disposal Facility Name: UNIVERSAL RESOURCE RECOVERY SANTA FE SPRINGS Rate (Per Ton): \$62.50

| Service Description | Collection Frequency (No. of Pickups per Week) | Monthly Unit Price/Rate | *Estimated No. of Collections per Week | Annual Amount (Monthly Unit Price/Rate x Estimated No. of Collections per Week x 12) |
|---------------------|--|-------------------------|--|--|
| 32-Gallon Cart | 1 | \$12.00 | | \$0.00 |
| | 2 | \$22.00 | | \$0.00 |
| | 3 | \$32.00 | | \$0.00 |
| | 4 | \$42.00 | | \$0.00 |
| | 5 | \$70.00 | | \$0.00 |
| | 6 | \$108.00 | | \$0.00 |
| | 7 | \$124.00 | | \$0.00 |

| | | | | |
|-----------------|---|------------|-----|-------------|
| 64-Gallon Cart | 1 | \$21.00 | 31 | \$7,812.00 |
| | 2 | \$32.00 | 1 | \$384.00 |
| | 3 | \$63.00 | | \$0.00 |
| | 4 | \$80.00 | | \$0.00 |
| | 5 | \$99.00 | | \$0.00 |
| | 6 | \$115.00 | | \$0.00 |
| | 7 | \$125.00 | | \$0.00 |
| 96-Gallon Cart | 1 | \$33.00 | 50 | \$19,800.00 |
| | 2 | \$62.70 | 5 | \$3,762.00 |
| | 3 | \$82.70 | | \$0.00 |
| | 4 | \$100.70 | | \$0.00 |
| | 5 | \$118.70 | 1 | \$1,424.40 |
| | 6 | \$137.70 | | \$0.00 |
| | 7 | \$162.70 | | \$0.00 |
| 1 CY Dumpster | 1 | \$45.00 | 135 | \$72,900.00 |
| | 2 | \$90.00 | 55 | \$59,400.00 |
| | 3 | \$135.00 | 41 | \$66,420.00 |
| | 4 | \$180.00 | 12 | \$25,920.00 |
| | 5 | \$225.00 | 7 | \$18,900.00 |
| | 6 | \$270.00 | 7 | \$22,680.00 |
| | 7 | \$315.00 | | \$0.00 |
| 1.5 CY Dumpster | 1 | \$48.00 | 15 | \$8,640.00 |
| | 2 | \$96.00 | 7 | \$8,064.00 |
| | 3 | \$144.00 | 12 | \$20,736.00 |
| | 4 | \$192.00 | 1 | \$2,304.00 |
| | 5 | \$240.00 | 4 | \$11,520.00 |
| | 6 | \$288.00 | 2 | \$6,912.00 |
| | 7 | \$336.00 | | \$0.00 |
| 2 CY Dumpster | 1 | \$52.00 | 6 | \$3,744.00 |
| | 2 | \$104.00 | 2 | \$2,496.00 |
| | 3 | \$156.00 | 12 | \$22,464.00 |
| | 4 | \$208.00 | 1 | \$2,496.00 |
| | 5 | \$260.00 | | \$0.00 |
| | 6 | \$312.00 | 2 | \$7,488.00 |
| | 7 | \$364.00 | | \$0.00 |
| 3 CY Dumpster | 1 | \$92.00 | 1 | \$1,104.00 |
| | 2 | \$184.00 | 2 | \$4,416.00 |
| | 3 | \$276.00 | 1 | \$3,312.00 |
| | 4 | \$300.00 | 2 | \$7,200.00 |
| | 5 | \$460.00 | | \$0.00 |
| | 6 | \$552.00 | | \$0.00 |
| | 7 | \$644.00 | | \$0.00 |
| 4 CY Dumpster | 1 | \$148.00 | | \$0.00 |
| | 2 | \$296.00 | | \$0.00 |
| | 3 | \$444.00 | | \$0.00 |
| | 4 | \$592.00 | | \$0.00 |
| | 5 | \$740.00 | | \$0.00 |
| | 6 | \$888.00 | | \$0.00 |
| | 7 | \$1,036.00 | | \$0.00 |

| | | | | |
|--------------------------------|---|------------|----|-------------|
| 6 CY Dumpster | 1 | \$188.00 | | \$0.00 |
| | 2 | \$376.00 | | \$0.00 |
| | 3 | \$564.00 | | \$0.00 |
| | 4 | \$752.00 | | \$0.00 |
| | 5 | \$940.00 | | \$0.00 |
| | 6 | \$1,128.00 | | \$0.00 |
| | 7 | \$1,316.00 | | \$0.00 |
| 8 CY to 40 CY Roll-offs | 1 | \$115.00 | 18 | \$24,840.00 |
| | 2 | \$230.00 | 1 | \$2,760.00 |
| | 3 | \$345.00 | | \$0.00 |
| | 4 | \$460.00 | | \$0.00 |
| | 5 | \$575.00 | | \$0.00 |
| | 6 | \$690.00 | | \$0.00 |
| | 7 | \$805.00 | | \$0.00 |
| Compactor | 1 | \$119.00 | | \$0.00 |
| | 2 | \$238.00 | | \$0.00 |
| | 3 | \$357.00 | | \$0.00 |
| | 4 | \$476.00 | | \$0.00 |
| | 5 | \$595.00 | | \$0.00 |
| | 6 | \$714.00 | | \$0.00 |
| | 7 | \$833.00 | | \$0.00 |

Total Proposed Annual Amount (1A) **\$439,898.40**

Permanent Roll-Offs and Compactors: All 8, 10, 20, 30, 40 CY Roll-offs and compactors are pull rates only; total cost will be based on actual Disposal and/or Processing costs. Rates charged to Customers should include the total cost for pull, Processing and Disposal rates.

Temporary Roll-offs (Non-permanent service of no more than 30 consecutive days at Customer's site): Shall be charged as accordingly to the Service Rates indicated above and may charge an additional daily rental fee (See Extra Services Fees).

Discounted Rates for Customers with Waivers and Exemptions

Proposer must provide discounted rates for Customers that have been issued waivers and exemptions for part or all of Collection Services. Proposer must insert the discounted rate in the yellow box below for Customers that have been issued a waiver/exemption for Organic Waste Collection Services.

| Customer Scenarios | Monthly Rate |
|---|---|
| 1) Customer that Self-Hauls Refuse, Recyclables and Organic Waste. | \$0.00 for Solid Waste Collection Services |
| 2) Customer that Self-Hauls Refuse only (Customer still needs to subscribe to Organic Waste and Recyclables Collection). | \$0.00 for Refuse |
| 3) Customer that Self-Hauls Organic Waste and has an Organic Waste waiver/exemption (Customer still needs to subscribe to Refuse and Recyclables Collection). | The Monthly Rate to Customer should be \$0.00 for Organic Waste. For Refuse, all monthly rates should be discounted by \$25.00 of the Solid Waste Collection Service Rates. |

*Estimated No. of Collections per Week is based on 2019 Customer data submitted by the current non-exclusive commercial franchise waste haulers. Each of the Service Areas have different Customer counts.

Additional Entry: (Proposer may use this space to add additional information such as additional facilities and if Proposer would like to add any additional service levels and Container sizes that may have not been identified above)

The undersigned Proposer offers to perform the work described in the Request for Proposals (RFP) for the following price(s). The Proposer rate(s) (hourly, monthly, etc.) shall include all administrative costs, franchise fees, labor, supervision, overtime, materials, transportation, taxes, equipment, and supplies unless stated otherwise in the RFP. The Proposer understands and agrees that the quantities set forth in the Schedule of Prices by the County are only estimates are based on current hauler submittals. Any unit prices quoted by the Proposer in this Schedule of Prices will apply to the actual quantities of work. The Proposer may use the estimates to develop its cost and rate proposal. The Proposer understands and agrees that each of the Service Areas have different Customer counts. County makes no representation or warranties of any kind, expressed or implied, as to the accuracy of the information set forth in the Schedule of Prices. County will not be liable for any damages or loss of any nature, including, but not limited to, lost profits, resulting from the estimates provided by the County. Proposer agrees to indemnify and hold the County harmless with respect to any issues, disputes, claims, lawsuits resulting from the estimates provided by the County in this solicitation, and in particular, as set forth in the Schedule of Prices. It is the responsibility of the proposer to undertake, at its sole cost, any verification of any and all information necessary for the preparation and submittal of a response to this RFP.

It is the County's sole discretion to select the collection method for each Service Area after receipt of all proposals. The County's selected collection method may not be the lowest cost collection method. The County may consider factors including but not limited to, cost per cubic yard, readiness to implement, regulatory compliance, and waste diversion potential, when deciding upon a collection method for each Service Area.

Instructions: Proposer shall enter proposed monthly rates in the blue boxes below. Proposer must submit a proposal/bid for each collection method: Three-Container, Two-Container and One-Container collection methods. Failure to do so may result in the proposal/bid being rejected as nonresponsive. All proposers should include the 14% franchise fee in their proposed rates. Proposers shall not change the numbers in Column D- Estimated No. of Collections per Week. Column E will autocalculate the Proposed Annual Amount for each service. The Proposed Total Annual Amounts for Collection Services of the County selected collection method will be used for the evaluation evaluated. Proposer is responsible for ensuring accuracy of calculations.

Additional Containers for Recyclables

Note: The following rates apply to Commercial Customers. These are the rates that are requested in addition to the Minimum Default Collection Service. Recycling rates should be no more than half of the Refuse rates. The Minimum Default Collection Service includes the equivalent of 96 gallons of weekly Recycling Collection Service per Customer at no additional charge.

Processing Facility Name: MADISON MATERIALS Rate (Per Ton): \$72.50

Backup Processing Facility Name: UNIVERSAL RESOURCE RECOVERY SANTA FE SPRINGS Rate (Per Ton): \$62.50

| Service Description | Collection Frequency (No. of Pickups per Week) | Monthly Unit Price/Rate | *Estimated No. of Collections per Week | Annual Amount (Monthly Unit Price/Rate x Estimated No. of Collections per Week x 12) |
|---------------------|--|-------------------------|--|--|
| 32-Gallon Cart | 1 | \$6.00 | | \$0.00 |
| | 2 | \$11.00 | | \$0.00 |
| | 3 | \$16.00 | | \$0.00 |
| | 4 | \$21.00 | | \$0.00 |
| | 5 | \$35.00 | | \$0.00 |
| | 6 | \$54.00 | | \$0.00 |
| | 7 | \$62.00 | | \$0.00 |
| 64-Gallon Cart | 1 | \$ 10.50 | | \$0.00 |
| | 2 | \$ 16.00 | | \$0.00 |
| | 3 | \$ 31.50 | | \$0.00 |
| | 4 | \$ 40.00 | | \$0.00 |
| | 5 | \$ 49.50 | | \$0.00 |
| | 6 | \$ 57.50 | | \$0.00 |
| | 7 | \$ 62.50 | | \$0.00 |

| | | | | |
|------------------------|----------|---------|-------------|------------|
| 96-Gallon Cart | 1 | \$16.50 | 7 | \$1,386.00 |
| | 2 | \$31.35 | | \$0.00 |
| | 3 | \$41.35 | | \$0.00 |
| | 4 | \$50.35 | | \$0.00 |
| | 5 | \$59.35 | | \$0.00 |
| | 6 | \$68.85 | | \$0.00 |
| | 7 | \$81.35 | | \$0.00 |
| 1 CY Dumpster | | | | |
| 1 | \$22.50 | 81 | \$21,870.00 | |
| 2 | \$45.00 | 6 | \$3,240.00 | |
| 3 | \$67.50 | | \$0.00 | |
| 4 | \$90.00 | | \$0.00 | |
| 5 | \$112.50 | 1 | \$1,350.00 | |
| 6 | \$135.00 | | \$0.00 | |
| 7 | \$157.50 | | \$0.00 | |
| 1.5 CY Dumpster | | | | |
| 1 | \$24.00 | 134 | \$38,592.00 | |
| 2 | \$48.00 | 52 | \$29,952.00 | |
| 3 | \$72.00 | 61 | \$52,704.00 | |
| 4 | \$96.00 | 13 | \$14,976.00 | |
| 5 | \$120.00 | 3 | \$4,320.00 | |
| 6 | \$144.00 | 8 | \$13,824.00 | |
| 7 | \$168.00 | | \$0.00 | |
| 2 CY Dumpster | | | | |
| 1 | \$26.00 | 13 | \$4,056.00 | |
| 2 | \$52.00 | 13 | \$8,112.00 | |
| 3 | \$78.00 | 4 | \$3,744.00 | |
| 4 | \$104.00 | 1 | \$1,248.00 | |
| 5 | \$130.00 | 4 | \$6,240.00 | |
| 6 | \$156.00 | 3 | \$5,616.00 | |
| 7 | \$182.00 | | \$0.00 | |
| 3 CY Dumpster | | | | |
| 1 | \$46.00 | 3 | \$1,656.00 | |
| 2 | \$92.00 | 1 | \$1,104.00 | |
| 3 | \$138.00 | 1 | \$1,656.00 | |
| 4 | \$150.00 | 2 | \$3,600.00 | |
| 5 | \$230.00 | 4 | \$11,040.00 | |
| 6 | \$276.00 | | \$0.00 | |
| 7 | \$322.00 | | \$0.00 | |
| 4 CY Dumpster | | | | |
| 1 | \$74.00 | | \$0.00 | |
| 2 | \$148.00 | | \$0.00 | |
| 3 | \$222.00 | | \$0.00 | |
| 4 | \$296.00 | | \$0.00 | |
| 5 | \$370.00 | | \$0.00 | |
| 6 | \$444.00 | | \$0.00 | |
| 7 | \$518.00 | | \$0.00 | |
| 6 CY Dumpster | | | | |
| 1 | \$94.00 | | \$0.00 | |
| 2 | \$188.00 | | \$0.00 | |
| 3 | \$282.00 | | \$0.00 | |
| 4 | \$376.00 | | \$0.00 | |
| 5 | \$470.00 | | \$0.00 | |
| 6 | \$564.00 | | \$0.00 | |
| 7 | \$658.00 | | \$0.00 | |

| | | | | |
|---|---|----------|----|---------------------|
| 8 CY to 40 CY Roll-offs | 1 | \$57.50 | 18 | \$12,420.00 |
| | 2 | \$115.00 | 1 | \$1,380.00 |
| | 3 | \$172.50 | | \$0.00 |
| | 4 | \$230.00 | | \$0.00 |
| | 5 | \$287.50 | | \$0.00 |
| | 6 | \$345.00 | | \$0.00 |
| | 7 | \$402.50 | | \$0.00 |
| Compactor | 1 | \$59.50 | | \$0.00 |
| | 2 | \$119.00 | | \$0.00 |
| | 3 | \$178.50 | | \$0.00 |
| | 4 | \$238.00 | | \$0.00 |
| | 5 | \$297.50 | | \$0.00 |
| | 6 | \$357.00 | | \$0.00 |
| | 7 | \$416.50 | | \$0.00 |
| Total Proposed Annual Amount for (1B) | | | | \$244,086.00 |
| <p>Permanent Roll-Offs and Compactors: All 8, 10, 20, 30, 40 CY Roll-offs and compactors are pull rates only; total cost will be based on actual Disposal and/or Processing costs. Rates charged to Customers should include the total cost for pull, Processing and Disposal rates.</p> <p>Temporary Roll-offs (Non-permanent service of no more than 30 consecutive days at Customer's site): Shall be charged as accordingly to the Service Rates indicated above and may charge an additional daily rental fee (See Extra Services Fees).</p> | | | | |

*Estimated No. of Collections per Week is based on 2019 Customer data submitted by the current non-exclusive commercial franchise waste haulers. Each of the Service Areas have different Customer counts.

Additional Entry: (Proposer may use this space to add additional information such as additional facilities and if Proposer would like to add any additional service levels and Container sizes that may have not been identified above)

FORM PW-2.5.1 Schedule of Prices
Exclusive Commercial Franchise Services
Service Area: San Gabriel Valley West

Proposer Name: WARE DISPOSAL INC.

The undersigned Proposer offers to perform the work described in the Request for Proposals (RFP) for the following price(s). The Proposer rate(s) (hourly, monthly, etc.) shall include all administrative costs, franchise fees, labor, supervision, overtime, materials, transportation, taxes, equipment, and supplies unless stated otherwise in the RFP. The Proposer understands and agrees that the quantities set forth in the Schedule of Prices by the County are only estimates are based on current hauler submittals. Any unit prices quoted by the Proposer in this Schedule of Prices will apply to the actual quantities of work. The Proposer may use the estimates to develop its cost and rate proposal. The Proposer understands and agrees that each of the Service Areas have different Customer counts. County makes no representation or warranties of any kind, expressed or implied, as to the accuracy of the information set forth in the Schedule of Prices. County will not be liable for any damages or loss of any nature, including, but not limited to, lost profits, resulting from the estimates provided by the County. Proposer agrees to indemnify and hold the County harmless with respect to any issues, disputes, claims, lawsuits resulting from the estimates provided by the County in this solicitation, and in particular, as set forth in the Schedule of Prices. It is the responsibility of the proposer to undertake, at its sole cost, any verification of any and all information necessary for the preparation and submittal of a response to this RFP.

It is the County's sole discretion to select the collection method for each Service Area after receipt of all proposals. The County's selected collection method may not be the lowest cost collection method. The County may consider factors including but not limited to, cost per cubic yard, readiness to implement, regulatory compliance, and waste diversion potential, when deciding upon a collection method for each Service Area.

Instructions: Proposer shall enter proposed monthly rates in the blue boxes below. Proposer must submit a proposal/bid for each collection method: Three-Container, Two-Container and One-Container collection methods. Failure to do so may result in the proposal/bid being rejected as nonresponsive. All proposers should include the 14% franchise fee in their proposed rates. Proposers shall not change the numbers in Column D- Estimated No. of Collections per Week. Column E will autocalculate the Proposed Annual Amount for each service. The Proposed Total Annual Amounts for Collection Services of the County selected collection method will be used for the evaluation evaluated. Proposer is responsible for ensuring accuracy of calculations.

Additional Containers for Organic Waste

Note: The following rates apply to Commercial Customers. These are the rates that are requested in addition to the Minimum Default Collection Service. Organic Waste rates shall be no greater than the Refuse rates. The Minimum Default Collection Service includes the equivalent of 64 gallons of weekly Organic Waste Collection Service per Customer at no additional charge.

Processing Facility Name: UNIVERSAL RESOURCE RECOVERY SANTA FE SPRINGS Rate (Per Ton): \$125.00
Backup Processing Facility Name: PUENTE HILLS MRF Rate (Per Ton): \$112.07

| Service Description | Collection Frequency (No. of Pickups per Week) | Monthly Unit Price/Rate | *Estimated No. of Collections per Week | Annual Amount (Monthly Unit Price/Rate x Estimated No. of Collections per Week x 12) |
|---------------------|--|-------------------------|--|--|
| 32-Gallon Cart | 1 | \$12.00 | | \$0.00 |
| | 2 | \$22.00 | | \$0.00 |
| | 3 | \$32.00 | | \$0.00 |
| | 4 | \$42.00 | | \$0.00 |
| | 5 | \$70.00 | | \$0.00 |
| | 6 | \$108.00 | | \$0.00 |
| | 7 | \$124.00 | | \$0.00 |

| | | | | |
|--------------------------------|---|-----------|-----|-------------|
| 64-Gallon Cart | 1 | \$ 21.00 | 31 | \$7,812.00 |
| | 2 | \$ 32.00 | 1 | \$384.00 |
| | 3 | \$ 63.00 | | \$0.00 |
| | 4 | \$ 80.00 | | \$0.00 |
| | 5 | \$ 99.00 | | \$0.00 |
| | 6 | \$ 115.00 | | \$0.00 |
| | 7 | \$ 125.00 | | \$0.00 |
| 96-Gallon Cart | | | | |
| | 1 | \$29.70 | 50 | \$17,820.00 |
| | 2 | \$56.43 | 5 | \$3,385.80 |
| | 3 | \$74.43 | | \$0.00 |
| | 4 | \$90.63 | | \$0.00 |
| | 5 | \$106.83 | 1 | \$1,281.96 |
| | 6 | \$123.93 | | \$0.00 |
| | 7 | \$146.43 | | \$0.00 |
| 1 CY Dumpster | | | | |
| | 1 | \$40.50 | 137 | \$66,582.00 |
| | 2 | \$81.00 | 56 | \$54,432.00 |
| | 3 | \$121.50 | 52 | \$75,816.00 |
| | 4 | \$162.00 | 12 | \$23,328.00 |
| | 5 | \$202.50 | 7 | \$17,010.00 |
| | 6 | \$243.00 | 7 | \$20,412.00 |
| | 7 | \$283.50 | | \$0.00 |
| 1.5 CY Dumpster | | | | |
| | 1 | \$43.20 | 6 | \$3,110.40 |
| | 2 | \$86.40 | 6 | \$6,220.80 |
| | 3 | \$129.60 | 3 | \$4,665.60 |
| | 4 | \$172.80 | | \$0.00 |
| | 5 | \$216.00 | 4 | \$10,368.00 |
| | 6 | \$259.20 | | \$0.00 |
| | 7 | \$302.40 | | \$0.00 |
| 2 CY Dumpster | | | | |
| | 1 | \$46.80 | 13 | \$7,300.80 |
| | 2 | \$93.60 | 3 | \$3,369.60 |
| | 3 | \$140.40 | 10 | \$16,848.00 |
| | 4 | \$187.20 | 1 | \$2,246.40 |
| | 5 | \$234.00 | | \$0.00 |
| | 6 | \$280.80 | 2 | \$6,739.20 |
| | 7 | \$327.60 | | \$0.00 |
| 3 CY Dumpster | | | | |
| | 1 | \$55.80 | 1 | \$669.60 |
| | 2 | \$111.60 | 1 | \$1,339.20 |
| | 3 | \$167.40 | 1 | \$2,008.80 |
| | 4 | \$223.20 | 3 | \$8,035.20 |
| | 5 | \$279.00 | | \$0.00 |
| | 6 | \$334.80 | 2 | \$8,035.20 |
| | 7 | \$390.60 | | \$0.00 |
| 8 CY to 40 CY Roll-offs | | | | |
| | 1 | \$103.50 | | \$0.00 |
| | 2 | \$207.00 | 18 | \$44,712.00 |
| | 3 | \$310.50 | 1 | \$3,726.00 |
| | 4 | \$414.00 | | \$0.00 |
| | 5 | \$517.50 | | \$0.00 |
| | 6 | \$621.00 | | \$0.00 |
| | 7 | \$724.50 | | \$0.00 |

| | | | | |
|------------------|---|----------|--|--------|
| Compactor | 1 | \$107.10 | | \$0.00 |
| | 2 | \$214.20 | | \$0.00 |
| | 3 | \$321.30 | | \$0.00 |
| | 4 | \$428.40 | | \$0.00 |
| | 5 | \$535.50 | | \$0.00 |
| | 6 | \$642.60 | | \$0.00 |
| | 7 | \$749.70 | | \$0.00 |

| | | | | |
|--|--|--|--|---------------------|
| Total Proposed Annual Amount for (1C) | | | | \$417,658.56 |
|--|--|--|--|---------------------|

Permanent Roll-Offs and Compactors: All 8, 10, 20, 30, 40 CY Roll-offs and compactors are pull rates only; total cost will be based on actual Disposal and/or Processing costs. Rates charged to Customers should include the total cost for pull, Processing and Disposal rates.

Temporary Roll-offs (Non-permanent service of no more than 30 consecutive days at Customer's site): Shall be charged as accordingly to the Service Rates indicated above and may charge an additional daily rental fee (See Extra Services Fees).

*Estimated No. of Collections per Week is based on 2019 Customer data submitted by the current non-exclusive commercial franchise waste haulers. Each of the Service Areas have different Customer counts.

Additional Entry: (Proposer may use this space to add additional information such as additional facilities and if Proposer would like to add any additional service levels and Container sizes that may have not been identified above)

FORM PW-2.5.1 Schedule of Prices
Exclusive Commercial Franchise Services
Service Area: San Gabriel Valley West

Proposer Name: WARE DISPOSAL INC.

The undersigned Proposer offers to perform the work described in the Request for Proposals (RFP) for the following price(s). The Proposer rate(s) (hourly, monthly, etc.) shall include all administrative costs, franchise fees, labor, supervision, overtime, materials, transportation, taxes, equipment, and supplies unless stated otherwise in the RFP. The Proposer understands and agrees that the quantities set forth in the Schedule of Prices by the County are only estimates based on current hauler submittals. Any unit prices quoted by the Proposer in this Schedule of Prices will apply to the actual quantities of work. The Proposer may use the estimates to develop its cost and rate proposal. The Proposer understands and agrees that each of the Service Areas have different Customer counts. County makes no representation or warranties of any kind, expressed or implied, as to the accuracy of the information set forth in the Schedule of Prices. County will not be liable for any damages or loss of any nature, including, but not limited to, lost profits, resulting from the estimates provided by the County. Proposer agrees to indemnify and hold the County harmless with respect to any issues, disputes, claims, lawsuits resulting from the estimates provided by the County in this solicitation, and in particular, as set forth in the Schedule of Prices. It is the responsibility of the proposer to undertake, at its sole cost, any verification of any and all information necessary for the preparation and submittal of a response to this RFP.

It is the County's sole discretion to select the collection method for each Service Area after receipt of all proposals. The County's selected collection method may not be the lowest cost collection method. The County may consider factors including but not limited to, cost per cubic yard, readiness to implement, regulatory compliance, and waste diversion potential, when deciding upon a collection method for each Service Area.

Instructions: Proposer shall enter proposed monthly rates in the blue boxes below and the discounted rate for Customers who have a waiver/exemption for Organic Waste Collection Services in the yellow box below. Proposer must submit a proposal/bid for each collection method: Three-Container, Two-Container and One-Container collection methods. Failure to do so may result in the proposal/bid being rejected as nonresponsive. All proposers should include the 14% franchise fee in their proposed rates. Proposers shall not change the numbers in Column D- Estimated No. of Collections per Week. Column E will autocalculate the Proposed Annual Amount for each service. The Proposed Total Annual Amounts for Collection Services of the County selected collection method will be used for the evaluation evaluated. Proposer is responsible for ensuring accuracy of calculations..

Multifamily Collection Services (Three-Container)

Note: The following rates apply to Multifamily Customers. The Minimum Default Collection Service rate includes a minimum base rate for Refuse, Organic Waste, and Recyclables Collection Services. The minimum base rate for Refuse includes the equivalent of 64 gallons of weekly Organic Waste and 96 gallons of weekly Recycling Collection Service per Customer, both at no additional charge. Recycling rates shall be no more than half of the Refuse rates and Organic Waste rates shall be no greater than the Refuse rates.

Disposal Facility Name: PUENTE HILLS MRF Rate (Per Ton): \$69.92
Backup Disposal Facility Name: UNIVERSAL RESOURCE RECOVERY SANTA FE SPRINGS Rate (Per Ton): \$62.50

| Service Description | Collection Frequency (No. of Pickups per Week) | Monthly Unit Price/Rate | *Estimated No. of Collections per Week | Annual Amount (Monthly Unit Price/Rate x Estimated No. of Collections per Week x 12) |
|---------------------|--|-------------------------|--|--|
| 32-Gallon Cart | 1 | \$12.00 | | \$0.00 |
| | 2 | \$22.00 | | \$0.00 |
| | 3 | \$32.00 | | \$0.00 |
| | 4 | \$42.00 | | \$0.00 |
| | 5 | \$70.00 | | \$0.00 |
| | 6 | \$108.00 | | \$0.00 |
| | 7 | \$124.00 | | \$0.00 |

| | | | | |
|------------------------|---|----------|----|--------------|
| 64-Gallon Cart | 1 | \$21.00 | | \$0.00 |
| | 2 | \$32.00 | | \$0.00 |
| | 3 | \$63.00 | | \$0.00 |
| | 4 | \$80.00 | | \$0.00 |
| | 5 | \$99.00 | | \$0.00 |
| | 6 | \$115.00 | | \$0.00 |
| | 7 | \$125.00 | | \$0.00 |
| 96-Gallon Cart | | | | |
| 96-Gallon Cart | 1 | \$33.00 | | \$0.00 |
| | 2 | \$62.70 | | \$0.00 |
| | 3 | \$82.70 | | \$0.00 |
| | 4 | \$100.70 | | \$0.00 |
| | 5 | \$118.70 | | \$0.00 |
| | 6 | \$137.70 | | \$0.00 |
| | 7 | \$162.70 | | \$0.00 |
| 1 CY Dumpster | | | | |
| 1 CY Dumpster | 1 | \$45.00 | 11 | \$5,940.00 |
| | 2 | \$90.00 | 2 | \$2,160.00 |
| | 3 | \$135.00 | 2 | \$3,240.00 |
| | 4 | \$180.00 | | \$0.00 |
| | 5 | \$225.00 | | \$0.00 |
| | 6 | \$270.00 | | \$0.00 |
| | 7 | \$315.00 | | \$0.00 |
| 1.5 CY Dumpster | | | | |
| 1.5 CY Dumpster | 1 | \$48.00 | 18 | \$10,368.00 |
| | 2 | \$96.00 | 7 | \$8,064.00 |
| | 3 | \$144.00 | 1 | \$1,728.00 |
| | 4 | \$192.00 | 5 | \$11,520.00 |
| | 5 | \$240.00 | | \$0.00 |
| | 6 | \$288.00 | | \$0.00 |
| | 7 | \$336.00 | | \$0.00 |
| 2 CY Dumpster | | | | |
| 2 CY Dumpster | 1 | \$52.00 | 90 | \$56,160.00 |
| | 2 | \$104.00 | 62 | \$77,376.00 |
| | 3 | \$156.00 | 56 | \$104,832.00 |
| | 4 | \$208.00 | 19 | \$47,424.00 |
| | 5 | \$260.00 | | \$0.00 |
| | 6 | \$312.00 | | \$0.00 |
| | 7 | \$364.00 | | \$0.00 |
| 3 CY Dumpster | | | | |
| 3 CY Dumpster | 1 | \$92.00 | 13 | \$14,352.00 |
| | 2 | \$184.00 | 18 | \$39,744.00 |
| | 3 | \$276.00 | 19 | \$62,928.00 |
| | 4 | \$300.00 | 11 | \$39,600.00 |
| | 5 | \$460.00 | | \$0.00 |
| | 6 | \$552.00 | | \$0.00 |
| | 7 | \$644.00 | | \$0.00 |

| | | | | |
|---|---|--|---|---------------------|
| 4 CY Dumpster | 1 | \$148.00 | | \$0.00 |
| | 2 | \$296.00 | 1 | \$3,552.00 |
| | 3 | \$444.00 | | \$0.00 |
| | 4 | \$592.00 | | \$0.00 |
| | 5 | \$740.00 | | \$0.00 |
| | 6 | \$888.00 | | \$0.00 |
| | 7 | \$1,036.00 | | \$0.00 |
| 6 CY Dumpster | | | | |
| 6 CY Dumpster | 1 | \$188.00 | | \$0.00 |
| | 2 | \$376.00 | | \$0.00 |
| | 3 | \$564.00 | | \$0.00 |
| | 4 | \$752.00 | | \$0.00 |
| | 5 | \$940.00 | | \$0.00 |
| | 6 | \$1,128.00 | | \$0.00 |
| | 7 | \$1,316.00 | | \$0.00 |
| 8 CY to 40 CY Roll-offs | | | | |
| 8 CY to 40 CY Roll-offs | 1 | \$115.00 | | \$0.00 |
| | 2 | \$230.00 | | \$0.00 |
| | 3 | \$345.00 | | \$0.00 |
| | 4 | \$460.00 | | \$0.00 |
| | 5 | \$575.00 | | \$0.00 |
| | 6 | \$690.00 | | \$0.00 |
| | 7 | \$805.00 | | \$0.00 |
| Compactor | | | | |
| Compactor | 1 | \$119.00 | | \$0.00 |
| | 2 | \$238.00 | | \$0.00 |
| | 3 | \$357.00 | | \$0.00 |
| | 4 | \$476.00 | | \$0.00 |
| | 5 | \$595.00 | | \$0.00 |
| | 6 | \$714.00 | | \$0.00 |
| | 7 | \$833.00 | | \$0.00 |
| Total Proposed Annual Amount (2A) | | | | \$488,988.00 |
| <p>Permanent Roll-Offs and Compactors: All 8, 10, 20, 30, 40 CY Roll-offs and compactors are pull rates only; total cost will be based on actual Disposal and/or Processing costs. Rates charged to Customers should include the total cost for pull, Processing and Disposal rates.</p> <p>Temporary Roll-offs (Non-permanent service of no more than 30 consecutive days at Customer's site): Shall be charged as accordingly to the Service Rates indicated above and may charge an additional daily rental fee (See Extra Services Fees).</p> | | | | |
| <p>Discounted Rates for Customers with Waivers and Exemptions Proposer must provide discounted rates for Customers that have been issued waivers and exemptions for part or all of Collection Services. Proposer must insert the discounted rate in the yellow box below for Customers that have been issued a waiver/exemption for Organic Waste Collection Services.</p> | | | | |
| Customer Scenarios | | Monthly Rate | | |
| 1) Customer that Self-Hauls Refuse, Recyclables and Organic Waste. | | \$0.00 for Solid Waste Collection Services | | |
| 2) Customer that Self-Hauls Refuse only (Customer still needs to subscribe to Organic Waste and Recyclables Collection) | | \$0.00 for Refuse | | |
| 3) Customer that Self-Hauls Organic Waste and has an Organic Waste waiver/exemption (Customer still needs to subscribe to Refuse and Recyclables Collection). | | <p>The Monthly Rate to Customer should be \$0.00 for Organic Waste. For Refuse, all monthly rates should be discounted by \$25.00 of the Solid Waste Collection Service Rates.</p> | | |

*Estimated No. of Collections per Week is based on 2019 Customer data submitted by the current non-exclusive commercial franchise waste haulers. Each of the Service Areas have different Customer counts.

Additional Entry: (Proposer may use this space to add additional information such as additional facilities and if Proposer would like to add any additional service levels and Container sizes that may have not been identified above)

FORM PW-2.5.1 Schedule of Prices
Exclusive Commercial Franchise Services
Service Area: San Gabriel Valley West

Proposer Name: WARE DISPOSAL INC.

The undersigned Proposer offers to perform the work described in the Request for Proposals (RFP) for the following price(s). The Proposer rate(s) (hourly, monthly, etc.) shall include all administrative costs, franchise fees, labor, supervision, overtime, materials, transportation, taxes, equipment, and supplies unless stated otherwise in the RFP. The Proposer understands and agrees that the quantities set forth in the Schedule of Prices by the County are only estimates are based on current hauler submittals. Any unit prices quoted by the Proposer in this Schedule of Prices will apply to the actual quantities of work. The Proposer may use the estimates to develop its cost and rate proposal. The Proposer understands and agrees that each of the Service Areas have different Customer counts. County makes no representation or warranties of any kind, expressed or implied, as to the accuracy of the information set forth in the Schedule of Prices. County will not be liable for any damages or loss of any nature, including, but not limited to, lost profits, resulting from the estimates provided by the County. Proposer agrees to indemnify and hold the County harmless with respect to any issues, disputes, claims, lawsuits resulting from the estimates provided by the County in this solicitation, and in particular, as set forth in the Schedule of Prices. It is the responsibility of the proposer to undertake, at its sole cost, any verification of any and all information necessary for the preparation and submittal of a response to this RFP.

It is the County's sole discretion to select the collection method for each Service Area after receipt of all proposals. The County's selected collection method may not be the lowest cost collection method. The County may consider factors including but not limited to, cost per cubic yard, readiness to implement, regulatory compliance, and waste diversion potential, when deciding upon a collection method for each Service Area.

Instructions: Proposer shall enter proposed monthly rates in the blue boxes below. Proposer must submit a proposal/bid for each collection method: Three-Container, Two-Container and One-Container collection methods. Failure to do so may result in the proposal/bid being rejected as nonresponsive. All proposers should include the 14% franchise fee in their proposed rates. Proposers shall not change the numbers in Column D- Estimated No. of Collections per Week. Column E will autocalculate the Proposed Annual Amount for each service. The Proposed Total Annual Amounts for Collection Services of the County selected collection method will be used for the evaluation evaluated. Proposer is responsible for ensuring accuracy of calculations.

Additional Containers for Recyclables

Note: The following rates apply to Multifamily Customers. These are the rates that are requested in addition to the Minimum Default Collection Service. Recycling rates shall be no more than half of the Refuse rates. The Minimum Default Collection Service includes the equivalent of 96 gallons of weekly Recycling Collection Service per Customer at no additional charge.

Processing Facility Name: MADISON MATERIALS Rate (Per Ton): \$72.50
Backup Processing Facility Name: UNIVERSAL RESOURCE RECOVERY SANTA FE SPRINGS Rate (Per Ton): \$62.50

| Service Description | Collection Frequency (No. of Pickups per Week) | Monthly Unit Price/Rate | *Estimated No. of Collections per Week | Annual Amount (Monthly Unit Price/Rate x Estimated No. of Collections per Week x 12) |
|---------------------|--|-------------------------|--|--|
| 32-Gallon Cart | 1 | \$6.00 | | \$0.00 |
| | 2 | \$11.00 | | \$0.00 |
| | 3 | \$16.00 | | \$0.00 |
| | 4 | \$21.00 | | \$0.00 |
| | 5 | \$35.00 | | \$0.00 |
| | 6 | \$54.00 | | \$0.00 |
| | 7 | \$62.00 | | \$0.00 |
| 64-Gallon Cart | 1 | \$ 10.50 | | \$0.00 |
| | 2 | \$ 16.00 | | \$0.00 |
| | 3 | \$ 31.50 | | \$0.00 |
| | 4 | \$ 40.00 | | \$0.00 |
| | 5 | \$ 49.50 | | \$0.00 |
| | 6 | \$ 57.50 | | \$0.00 |
| | 7 | \$ 62.50 | | \$0.00 |

| | | | | |
|------------------------|---|----------|----|-------------|
| 96-Gallon Cart | 1 | \$16.50 | 3 | \$594.00 |
| | 2 | \$31.35 | | \$0.00 |
| | 3 | \$41.35 | | \$0.00 |
| | 4 | \$50.35 | | \$0.00 |
| | 5 | \$59.35 | | \$0.00 |
| | 6 | \$68.85 | | \$0.00 |
| | 7 | \$81.35 | | \$0.00 |
| 1 CY Dumpster | | | | |
| | 1 | \$22.50 | 26 | \$7,020.00 |
| | 2 | \$45.00 | 9 | \$4,860.00 |
| | 3 | \$67.50 | 3 | \$2,430.00 |
| | 4 | \$90.00 | 5 | \$5,400.00 |
| | 5 | \$112.50 | | \$0.00 |
| | 6 | \$135.00 | | \$0.00 |
| | 7 | \$157.50 | | \$0.00 |
| 1.5 CY Dumpster | | | | |
| | 1 | \$24.00 | 90 | \$25,920.00 |
| | 2 | \$48.00 | 62 | \$35,712.00 |
| | 3 | \$72.00 | 56 | \$48,384.00 |
| | 4 | \$96.00 | 19 | \$21,888.00 |
| | 5 | \$120.00 | | \$0.00 |
| | 6 | \$144.00 | | \$0.00 |
| | 7 | \$168.00 | | \$0.00 |
| 2 CY Dumpster | | | | |
| | 1 | \$26.00 | 13 | \$4,056.00 |
| | 2 | \$52.00 | 18 | \$11,232.00 |
| | 3 | \$78.00 | 19 | \$17,784.00 |
| | 4 | \$104.00 | 11 | \$13,728.00 |
| | 5 | \$130.00 | | \$0.00 |
| | 6 | \$156.00 | | \$0.00 |
| | 7 | \$182.00 | | \$0.00 |
| 3 CY Dumpster | | | | |
| | 1 | \$46.00 | | \$0.00 |
| | 2 | \$92.00 | 1 | \$1,104.00 |
| | 3 | \$138.00 | | \$0.00 |
| | 4 | \$150.00 | | \$0.00 |
| | 5 | \$230.00 | | \$0.00 |
| | 6 | \$276.00 | | \$0.00 |
| | 7 | \$322.00 | | \$0.00 |
| 4 CY Dumpster | | | | |
| | 1 | \$74.00 | | \$0.00 |
| | 2 | \$148.00 | | \$0.00 |
| | 3 | \$222.00 | | \$0.00 |
| | 4 | \$296.00 | | \$0.00 |
| | 5 | \$370.00 | | \$0.00 |
| | 6 | \$444.00 | | \$0.00 |
| | 7 | \$518.00 | | \$0.00 |
| 6 CY Dumpster | | | | |
| | 1 | \$94.00 | | \$0.00 |
| | 2 | \$188.00 | | \$0.00 |
| | 3 | \$282.00 | | \$0.00 |
| | 4 | \$376.00 | | \$0.00 |
| | 5 | \$470.00 | | \$0.00 |
| | 6 | \$564.00 | | \$0.00 |
| | 7 | \$658.00 | | \$0.00 |

| | | | | |
|---|---|----------|--|---------------------|
| 8 CY to 40 CY Roll-offs | 1 | \$57.50 | | \$0.00 |
| | 2 | \$115.00 | | \$0.00 |
| | 3 | \$172.50 | | \$0.00 |
| | 4 | \$230.00 | | \$0.00 |
| | 5 | \$287.50 | | \$0.00 |
| | 6 | \$345.00 | | \$0.00 |
| | 7 | \$402.50 | | \$0.00 |
| Compactor | | | | |
| Compactor | 1 | \$59.50 | | \$0.00 |
| | 2 | \$119.00 | | \$0.00 |
| | 3 | \$178.50 | | \$0.00 |
| | 4 | \$238.00 | | \$0.00 |
| | 5 | \$297.50 | | \$0.00 |
| | 6 | \$357.00 | | \$0.00 |
| | 7 | \$416.50 | | \$0.00 |
| Total Proposed Annual Amount (2B) | | | | \$200,112.00 |
| <p>Permanent Roll-Offs and Compactors: All 8, 10, 20, 30, 40 CY Roll-offs and compactors are pull rates only; total cost will be based on actual Disposal and/or Processing costs. Rates charged to Customers should include the total cost for pull, Processing and Disposal rates.</p> <p>Temporary Roll-offs (Non-permanent service of no more than 30 consecutive days at Customer's site): Shall be charged as accordingly to the Service Rates indicated above and may charge an additional daily rental fee (See Extra Services Fees).</p> | | | | |

*Estimated No. of Collections per Week is based on 2019 Customer data submitted by the current non-exclusive commercial franchise waste haulers. Each of the Service Areas have different Customer counts.

Additional Entry: (Proposer may use this space to add additional information such as additional facilities and if Proposer would like to add any additional service levels and Container sizes that may have not been identified above)

The undersigned Proposer offers to perform the work described in the Request for Proposals (RFP) for the following price(s). The Proposer rate(s) (hourly, monthly, etc.) shall include all administrative costs, franchise fees, labor, supervision, overtime, materials, transportation, taxes, equipment, and supplies unless stated otherwise in the RFP. The Proposer understands and agrees that the quantities set forth in the Schedule of Prices by the County are only estimates are based on current hauler submittals. Any unit prices quoted by the Proposer in this Schedule of Prices will apply to the actual quantities of work. The Proposer may use the estimates to develop its cost and rate proposal. The Proposer understands and agrees that each of the Service Areas have different Customer counts. County makes no representation or warranties of any kind, expressed or implied, as to the accuracy of the information set forth in the Schedule of Prices. County will not be liable for any damages or loss of any nature, including, but not limited to, lost profits, resulting from the estimates provided by the County. Proposer agrees to indemnify and hold the County harmless with respect to any issues, disputes, claims, lawsuits resulting from the estimates provided by the County in this solicitation, and in particular, as set forth in the Schedule of Prices. It is the responsibility of the proposer to undertake, at its sole cost, any verification of any and all information necessary for the preparation and submittal of a response to this RFP.

It is the County's sole discretion to select the collection method for each Service Area after receipt of all proposals. The County's selected collection method may not be the lowest cost collection method. The County may consider factors including but not limited to, cost per cubic yard, readiness to implement, regulatory compliance, and waste diversion potential, when deciding upon a collection method for each Service Area.

Instructions: Proposer shall enter proposed monthly rates in the blue boxes below. Proposer must submit a proposal/bid for each collection method: Three-Container, Two-Container and One-Container collection methods. Failure to do so may result in the proposal/bid being rejected as nonresponsive. All proposers should include the 14% franchise fee in their proposed rates. Proposers shall not change the numbers in Column D- Estimated No. of Collections per Week. Column E will autocalculate the Proposed Annual Amount for each service. The Proposed Total Annual Amounts for Collection Services of the County selected collection method will be used for the evaluation evaluated. Proposer is responsible for ensuring accuracy of calculations.

Additional Containers for Organic Waste

Note: The following rates apply to Multifamily Customers. These are the rates that are requested in addition to the Minimum Default Collection Service. Organic Waste rates shall be no greater than the Refuse rates. The Minimum Default Collection Service includes the equivalent of 64 gallons of weekly Organic Waste Collection Service per Customer at no additional charge.

Processing Facility Name: UNIVERSAL RESOURCE RECOVERY SANTA FE SPRINGS Rate (Per Ton): \$125.00
Backup Processing Facility Name: PUENTE HILLS MRF Rate (Per Ton): \$112.07

| Service Description | Collection Frequency (No. of Pickups per Week) | Monthly Unit Price/Rate | *Estimated No. of Collections per Week | Annual Amount (Monthly Unit Price/Rate x Estimated No. of Collections per Week x 12) |
|---------------------|--|-------------------------|--|--|
| 32-Gallon Cart | 1 | \$12.00 | | \$0.00 |
| | 2 | \$22.00 | | \$0.00 |
| | 3 | \$32.00 | | \$0.00 |
| | 4 | \$42.00 | | \$0.00 |
| | 5 | \$70.00 | | \$0.00 |
| | 6 | \$108.00 | | \$0.00 |
| | 7 | \$124.00 | | \$0.00 |
| 64-Gallon Cart | 1 | \$ 21.00 | 3 | \$756.00 |
| | 2 | \$ 32.00 | | \$0.00 |
| | 3 | \$ 63.00 | | \$0.00 |
| | 4 | \$ 80.00 | | \$0.00 |
| | 5 | \$ 99.00 | | \$0.00 |
| | 6 | \$ 115.00 | | \$0.00 |
| | 7 | \$ 125.00 | | \$0.00 |
| 96-Gallon Cart | 1 | \$29.70 | 8 | \$2,851.20 |
| | 2 | \$56.43 | 2 | \$1,354.32 |

| | | | | |
|--|---|----------|-----|---------------------|
| | 3 | \$74.43 | 2 | \$1,786.32 |
| | 4 | \$90.63 | | \$0.00 |
| | 5 | \$106.83 | | \$0.00 |
| | 6 | \$123.93 | | \$0.00 |
| | 7 | \$146.43 | | \$0.00 |
| 1 CY Dumpster | 1 | \$40.50 | 108 | \$52,488.00 |
| | 2 | \$81.00 | 69 | \$67,068.00 |
| | 3 | \$121.50 | 57 | \$83,106.00 |
| | 4 | \$162.00 | 24 | \$46,656.00 |
| | 5 | \$202.50 | | \$0.00 |
| | 6 | \$243.00 | | \$0.00 |
| | 7 | \$283.50 | | \$0.00 |
| 1.5 CY Dumpster | 1 | \$43.20 | 13 | \$6,739.20 |
| | 2 | \$86.40 | 18 | \$18,662.40 |
| | 3 | \$129.60 | 19 | \$29,548.80 |
| | 4 | \$172.80 | 11 | \$22,809.60 |
| | 5 | \$216.00 | | \$0.00 |
| | 6 | \$259.20 | | \$0.00 |
| | 7 | \$302.40 | | \$0.00 |
| 2 CY Dumpster | 1 | \$46.80 | | \$0.00 |
| | 2 | \$93.60 | 1 | \$1,123.20 |
| | 3 | \$140.40 | | \$0.00 |
| | 4 | \$187.20 | | \$0.00 |
| | 5 | \$234.00 | | \$0.00 |
| | 6 | \$280.80 | | \$0.00 |
| | 7 | \$327.60 | | \$0.00 |
| 3 CY Dumpster | 1 | \$55.80 | | \$0.00 |
| | 2 | \$111.60 | | \$0.00 |
| | 3 | \$167.40 | | \$0.00 |
| | 4 | \$223.20 | | \$0.00 |
| | 5 | \$279.00 | | \$0.00 |
| | 6 | \$334.80 | | \$0.00 |
| | 7 | \$390.60 | | \$0.00 |
| 8 CY to 40 CY Roll-offs | 1 | \$103.50 | | \$0.00 |
| | 2 | \$207.00 | | \$0.00 |
| | 3 | \$310.50 | | \$0.00 |
| | 4 | \$414.00 | | \$0.00 |
| | 5 | \$517.50 | | \$0.00 |
| | 6 | \$621.00 | | \$0.00 |
| | 7 | \$724.50 | | \$0.00 |
| Compactor | 1 | \$107.10 | | \$0.00 |
| | 2 | \$214.20 | | \$0.00 |
| | 3 | \$321.30 | | \$0.00 |
| | 4 | \$428.40 | | \$0.00 |
| | 5 | \$535.50 | | \$0.00 |
| | 6 | \$642.60 | | \$0.00 |
| | 7 | \$749.70 | | \$0.00 |
| Total Proposed Annual Amount (2C) | | | | \$334,949.04 |

Permanent Roll-Offs and Compactors: All 8, 10, 20, 30, 40 CY Roll-offs and compactors are pull rates only; total cost will be based on actual Disposal and/or Processing costs. Rates charged to Customers should include the total cost for pull, Processing and Disposal rates.
Temporary Roll-offs (Non-permanent service of no more than 30 consecutive days at Customer's site): Shall be charged as accordingly to the Service Rates indicated above and may charge an additional daily rental fee (See Extra Services Fees).

*Estimated No. of Collections per Week is based on 2019 Customer data submitted by the current non-exclusive commercial franchise waste haulers. Each of the Service Areas have different Customer counts.

Additional Entry: *(Proposer may use this space to add additional information such as additional facilities and if Proposer would like to add any additional service levels and Container sizes that may have not been identified above)*

FORM PW-2.5.1 Schedule of Prices
Exclusive Commercial Franchise Services
Service Area: San Gabriel Valley West

Proposer Name: WARE DISPOSAL INC.

The undersigned Proposer offers to perform the work described in the Request for Proposals (RFP) for the following price(s). The Proposer rate(s) (hourly, monthly, etc.) shall include all administrative costs, franchise fees, labor, supervision, overtime, materials, transportation, taxes, equipment, and supplies unless stated otherwise in the RFP. The Proposer understands and agrees that the quantities set forth in the Schedule of Prices by the County are only estimates are based on current hauler submittals. Any unit prices quoted by the Proposer in this Schedule of Prices will apply to the actual quantities of work. The Proposer may use the estimates to develop its cost and rate proposal. The Proposer understands and agrees that each of the Service Areas have different Customer counts. County makes no representation or warranties of any kind, expressed or implied, as to the accuracy of the information set forth in the Schedule of Prices. County will not be liable for any damages or loss of any nature, including, but not limited to, lost profits, resulting from the estimates provided by the County. Proposer agrees to indemnify and hold the County harmless with respect to any issues, disputes, claims, lawsuits resulting from the estimates provided by the County in this solicitation, and in particular, as set forth in the Schedule of Prices. It is the responsibility of the proposer to undertake, at its sole cost, any verification of any and all information necessary for the preparation and submittal of a response to this RFP.

It is the County's sole discretion to select the collection method for each Service Area after receipt of all proposals. The County's selected collection method may not be the lowest cost collection method. The County may consider factors including but not limited to, cost per cubic yard, readiness to implement, regulatory compliance, and waste diversion potential, when deciding upon a collection method for each Service Area.

Instructions: Proposer shall enter proposed monthly rates in the blue boxes below and the discounted rate for Customers who have a waiver/exemption for Organic Waste Collection Services in the yellow box below. Proposer must submit a proposal/bid for each collection method: Three-Container, Two-Container and One-Container collection methods. Failure to do so may result in the proposal/bid being rejected as nonresponsive. All proposers should include the 14% franchise fee in their proposed rates. Proposers shall not change the numbers in Column D- Estimated No. of Collections per Week. Column E will autocalculate the Proposed Annual Amount for each service. The Proposed Total Annual Amounts for Collection Services of the County selected collection method will be used for the evaluation evaluated. Proposer is responsible for ensuring accuracy of calculations.

Residential Collection Services (Three-Container)

Note: The following rates apply to Residential (Single Family) Customers. The Minimum Default Collection Service rate includes a minimum base rate for Refuse, Organic Waste, and Recyclables Collection Services. The minimum base rate for Refuse includes the equivalent of 64 gallons of weekly Organic Waste and 96 gallons of weekly Recycling Collection Service per Customer, both at no additional charge.

Recycling rates shall be no more than half of the Refuse rates and Organic Waste rates shall be no greater than the Refuse rates.

Disposal Facility Name: PUENTE HILLS MRF Rate (Per Ton): \$69.92

Backup Disposal Facility Name: UNIVERSAL RESOURCE RECOVERY SANTA FE SPRINGS Rate (Per Ton): \$62.50

| Service Description | Collection Frequency (No. of Pickups per Week) | Monthly Unit Price/Rate | *Estimated No. of Collections per Week | Annual Amount (Monthly Unit Price/Rate x Estimated No. of Collections per Week x 12) |
|---------------------|--|-------------------------|--|--|
| 32-Gallon Cart | 1 | \$12.00 | | \$0.00 |
| | 2 | \$22.00 | | \$0.00 |
| | 3 | \$32.00 | | \$0.00 |
| | 4 | \$42.00 | | \$0.00 |
| | 5 | \$70.00 | | \$0.00 |
| | 6 | \$108.00 | | \$0.00 |
| | 7 | \$124.00 | | \$0.00 |
| 64-Gallon Cart | 1 | \$21.00 | | \$0.00 |
| | 2 | \$32.00 | | \$0.00 |
| | 3 | \$63.00 | | \$0.00 |
| | 4 | \$80.00 | | \$0.00 |
| | 5 | \$99.00 | | \$0.00 |
| | 6 | \$115.00 | | \$0.00 |
| | 7 | \$125.00 | | \$0.00 |

| | | | | |
|------------------------|---|------------|----|-------------|
| 96-Gallon Cart | 1 | \$33.00 | | \$0.00 |
| | 2 | \$62.70 | | \$0.00 |
| | 3 | \$82.70 | | \$0.00 |
| | 4 | \$100.70 | | \$0.00 |
| | 5 | \$118.70 | | \$0.00 |
| | 6 | \$137.70 | | \$0.00 |
| | 7 | \$162.70 | | \$0.00 |
| 1 CY Dumpster | | | | |
| | 1 | \$45.00 | 1 | \$540.00 |
| | 2 | \$90.00 | | \$0.00 |
| | 3 | \$135.00 | | \$0.00 |
| | 4 | \$180.00 | | \$0.00 |
| | 5 | \$225.00 | | \$0.00 |
| | 6 | \$270.00 | | \$0.00 |
| | 7 | \$315.00 | | \$0.00 |
| 1.5 CY Dumpster | | | | |
| | 1 | \$48.00 | 25 | \$14,400.00 |
| | 2 | \$96.00 | | \$0.00 |
| | 3 | \$144.00 | | \$0.00 |
| | 4 | \$192.00 | | \$0.00 |
| | 5 | \$240.00 | | \$0.00 |
| | 6 | \$288.00 | | \$0.00 |
| | 7 | \$336.00 | | \$0.00 |
| 2 CY Dumpster | | | | |
| | 1 | \$52.00 | 25 | \$15,600.00 |
| | 2 | \$104.00 | 1 | \$1,248.00 |
| | 3 | \$156.00 | | \$0.00 |
| | 4 | \$208.00 | | \$0.00 |
| | 5 | \$260.00 | | \$0.00 |
| | 6 | \$312.00 | | \$0.00 |
| | 7 | \$364.00 | | \$0.00 |
| 3 CY Dumpster | | | | |
| | 1 | \$92.00 | 77 | \$85,008.00 |
| | 2 | \$184.00 | 15 | \$33,120.00 |
| | 3 | \$276.00 | | \$0.00 |
| | 4 | \$300.00 | | \$0.00 |
| | 5 | \$460.00 | | \$0.00 |
| | 6 | \$552.00 | | \$0.00 |
| | 7 | \$644.00 | | \$0.00 |
| 4 CY Dumpster | | | | |
| | 1 | \$148.00 | 1 | \$1,776.00 |
| | 2 | \$296.00 | | \$0.00 |
| | 3 | \$444.00 | | \$0.00 |
| | 4 | \$592.00 | | \$0.00 |
| | 5 | \$740.00 | | \$0.00 |
| | 6 | \$888.00 | | \$0.00 |
| | 7 | \$1,036.00 | | \$0.00 |
| 6 CY Dumpster | | | | |
| | 1 | \$188.00 | | \$0.00 |
| | 2 | \$376.00 | | \$0.00 |
| | 3 | \$564.00 | | \$0.00 |
| | 4 | \$752.00 | | \$0.00 |
| | 5 | \$940.00 | | \$0.00 |
| | 6 | \$1,128.00 | | \$0.00 |
| | 7 | \$1,316.00 | | \$0.00 |

| | | | | |
|-------------------------|---|----------|---|------------|
| 8 CY to 40 CY Roll-offs | 1 | \$115.00 | 2 | \$2,760.00 |
| | 2 | \$230.00 | | \$0.00 |
| | 3 | \$345.00 | | \$0.00 |
| | 4 | \$460.00 | | \$0.00 |
| | 5 | \$575.00 | | \$0.00 |
| | 6 | \$690.00 | | \$0.00 |
| | 7 | \$805.00 | | \$0.00 |
| Compactor | | | | |
| | 1 | \$119.00 | | \$0.00 |
| | 2 | \$238.00 | | \$0.00 |
| | 3 | \$357.00 | | \$0.00 |
| | 4 | \$476.00 | | \$0.00 |
| | 5 | \$595.00 | | \$0.00 |
| | 6 | \$714.00 | | \$0.00 |
| | 7 | \$833.00 | | \$0.00 |

| | | | | |
|--|--|--|--|---------------------|
| Total Proposed Annual Amount (3A) | | | | \$154,452.00 |
|--|--|--|--|---------------------|

Permanent Roll-Offs and Compactors: All 8, 10, 20, 30, 40 CY Roll-offs and compactors are pull rates only; total cost will be based on actual Disposal and/or Processing costs. Rates charged to Customers should include the total cost for pull, Processing and Disposal rates.

Temporary Roll-offs (Non-permanent service of no more than 30 consecutive days at Customer's site): Shall be charged as accordingly to the Service Rates indicated above and may charge an additional daily rental fee (See Extra Services Fees).

Discounted Rates for Customers with Waivers and Exemptions
 Proposer must provide discounted rates for Customers that have been issued waivers and exemptions for part or all of Collection Services. Proposer must insert the discounted rate in the yellow box below for Customers that have been issued a waiver/exemption for Organic Waste Collection Services.

| Customer Scenarios | Monthly Rate |
|---|---|
| 1) Customer that Self-Hauls Refuse, Recyclables and Organic Waste. | \$0.00 for Solid Waste Collection Services |
| 2) Customer that Self-Hauls Refuse only (Customer still needs to subscribe to Organic Waste and Recyclables Collection). | \$0.00 for Refuse |
| 3) Customer that Self-Hauls Organic Waste and has an Organic Waste waiver/exemption (Customer still needs to subscribe to Refuse and Recyclables Collection). | The Monthly Rate to Customer should be \$0.00 for Organic Waste. For Refuse, all monthly rates should be discounted by \$25.00 of the Solid Waste Collection Service Rates. |

*Estimated No. of Collections per Week is based on 2019 Customer data submitted by the current non-exclusive commercial franchise waste haulers. Each of the Service Areas have different Customer counts.

Additional Entry: (Proposer may use this space to add additional information such as additional facilities and if Proposer would like to add any additional service levels and Container sizes that may have not been identified above)

The undersigned Proposer offers to perform the work described in the Request for Proposals (RFP) for the following price(s). The Proposer rate(s) (hourly, monthly, etc.) shall include all administrative costs, franchise fees, labor, supervision, overtime, materials, transportation, taxes, equipment, and supplies unless stated otherwise in the RFP. The Proposer understands and agrees that the quantities set forth in the Schedule of Prices by the County are only estimates are based on current hauler submittals. Any unit prices quoted by the Proposer in this Schedule of Prices will apply to the actual quantities of work. The Proposer may use the estimates to develop its cost and rate proposal. The Proposer understands and agrees that each of the Service Areas have different Customer counts. County makes no representation or warranties of any kind, expressed or implied, as to the accuracy of the information set forth in the Schedule of Prices. County will not be liable for any damages or loss of any nature, including, but not limited to, lost profits, resulting from the estimates provided by the County. Proposer agrees to indemnify and hold the County harmless with respect to any issues, disputes, claims, lawsuits resulting from the estimates provided by the County in this solicitation, and in particular, as set forth in the Schedule of Prices. It is the responsibility of the proposer to undertake, at its sole cost, any verification of any and all information necessary for the preparation and submittal of a response to this RFP.

It is the County's sole discretion to select the collection method for each Service Area after receipt of all proposals. The County's selected collection method may not be the lowest cost collection method. The County may consider factors including but not limited to, cost per cubic yard, readiness to implement, regulatory compliance, and waste diversion potential, when deciding upon a collection method for each Service Area.

Instructions: Proposer shall enter proposed monthly rates in the blue boxes below. Proposer must submit a proposal/bid for each collection method: Three-Container, Two-Container and One-Container collection methods. Failure to do so may result in the proposal/bid being rejected as nonresponsive. All proposers should include the 14% franchise fee in their proposed rates. Proposers shall not change the numbers in Column D- Estimated No. of Collections per Week. Column E will autocalculate the Proposed Annual Amount for each service. The Proposed Total Annual Amounts for Collection Services of the County selected collection method will be used for the evaluation evaluated. Proposer is responsible for ensuring accuracy of calculations.

Additional Containers for Recyclables

Note: The following rates apply to Residential (Single Family) Customers. These are the rates that are requested in addition to the Minimum Default Collection Service. Recycling rates shall be no more than half of the Refuse rates. The Minimum Default Collection Service includes the equivalent of 96 gallons of weekly Recycling Collection Service per Customer at no additional charge.

Processing Facility Name: MADISON MATERIALS Rate (Per Ton): \$72.50

Backup Processing Facility Name: UNIVERSAL RESOURCE RECOVERY SANTA FE SPRINGS Rate (Per Ton): \$62.50

| Service Description | Collection Frequency (No. of Pickups per Week) | Monthly Unit Price/Rate | *Estimated No. of Collections per Week | Annual Amount (Monthly Unit Price/Rate x Estimated No. of Collections per Week x 12) |
|---------------------|--|-------------------------|--|--|
| 32-Gallon Cart | 1 | \$6.00 | | \$0.00 |
| | 2 | \$11.00 | | \$0.00 |
| | 3 | \$16.00 | | \$0.00 |
| | 4 | \$21.00 | | \$0.00 |
| | 5 | \$35.00 | | \$0.00 |
| | 6 | \$54.00 | | \$0.00 |
| | 7 | \$62.00 | | \$0.00 |
| 64-Gallon Cart | 1 | \$ 10.50 | 1 | \$126.00 |
| | 2 | \$ 16.00 | | \$0.00 |
| | 3 | \$ 31.50 | | \$0.00 |
| | 4 | \$ 40.00 | | \$0.00 |
| | 5 | \$ 49.50 | | \$0.00 |
| | 6 | \$ 57.50 | | \$0.00 |
| | 7 | \$ 62.50 | | \$0.00 |

| | | | | |
|------------------------|---|----------|----|-------------|
| 96-Gallon Cart | 1 | \$16.50 | 50 | \$9,900.00 |
| | 2 | \$31.35 | 1 | \$376.20 |
| | 3 | \$41.35 | | \$0.00 |
| | 4 | \$50.35 | | \$0.00 |
| | 5 | \$59.35 | | \$0.00 |
| | 6 | \$68.85 | | \$0.00 |
| | 7 | \$81.35 | | \$0.00 |
| 1 CY Dumpster | | | | |
| | 1 | \$22.50 | 78 | \$21,060.00 |
| | 2 | \$45.00 | 15 | \$8,100.00 |
| | 3 | \$67.50 | | \$0.00 |
| | 4 | \$90.00 | | \$0.00 |
| | 5 | \$112.50 | | \$0.00 |
| | 6 | \$135.00 | | \$0.00 |
| | 7 | \$157.50 | | \$0.00 |
| 1.5 CY Dumpster | | | | |
| | 1 | \$24.00 | | \$0.00 |
| | 2 | \$48.00 | | \$0.00 |
| | 3 | \$72.00 | | \$0.00 |
| | 4 | \$96.00 | | \$0.00 |
| | 5 | \$120.00 | | \$0.00 |
| | 6 | \$144.00 | | \$0.00 |
| | 7 | \$168.00 | | \$0.00 |
| 2 CY Dumpster | | | | |
| | 1 | \$26.00 | | \$0.00 |
| | 2 | \$52.00 | | \$0.00 |
| | 3 | \$78.00 | | \$0.00 |
| | 4 | \$104.00 | | \$0.00 |
| | 5 | \$130.00 | | \$0.00 |
| | 6 | \$156.00 | | \$0.00 |
| | 7 | \$182.00 | | \$0.00 |
| 3 CY Dumpster | | | | |
| | 1 | \$46.00 | | \$0.00 |
| | 2 | \$92.00 | | \$0.00 |
| | 3 | \$138.00 | | \$0.00 |
| | 4 | \$150.00 | | \$0.00 |
| | 5 | \$230.00 | | \$0.00 |
| | 6 | \$276.00 | | \$0.00 |
| | 7 | \$322.00 | | \$0.00 |
| 4 CY Dumpster | | | | |
| | 1 | \$74.00 | | \$0.00 |
| | 2 | \$148.00 | | \$0.00 |
| | 3 | \$222.00 | | \$0.00 |
| | 4 | \$296.00 | | \$0.00 |
| | 5 | \$370.00 | | \$0.00 |
| | 6 | \$444.00 | | \$0.00 |
| | 7 | \$518.00 | | \$0.00 |
| 6 CY Dumpster | | | | |
| | 1 | \$94.00 | | \$0.00 |
| | 2 | \$188.00 | | \$0.00 |
| | 3 | \$282.00 | | \$0.00 |
| | 4 | \$376.00 | | \$0.00 |
| | 5 | \$470.00 | | \$0.00 |
| | 6 | \$564.00 | | \$0.00 |
| | 7 | \$658.00 | | \$0.00 |

| | | | | |
|---|---|----------|---|--------------------|
| 8 CY to 40 CY Roll-offs | 1 | \$57.50 | 2 | \$1,380.00 |
| | 2 | \$115.00 | | \$0.00 |
| | 3 | \$172.50 | | \$0.00 |
| | 4 | \$230.00 | | \$0.00 |
| | 5 | \$287.50 | | \$0.00 |
| | 6 | \$345.00 | | \$0.00 |
| | 7 | \$402.50 | | \$0.00 |
| Compactor | | | | |
| | 1 | \$59.50 | | \$0.00 |
| | 2 | \$119.00 | | \$0.00 |
| | 3 | \$178.50 | | \$0.00 |
| | 4 | \$238.00 | | \$0.00 |
| | 5 | \$297.50 | | \$0.00 |
| | 6 | \$357.00 | | \$0.00 |
| | 7 | \$416.50 | | \$0.00 |
| Total Proposed Annual Amount (3B) | | | | \$40,942.20 |
| <p>Permanent Roll-Offs and Compactors: All 8, 10, 20, 30, 40 CY Roll-offs and compactors are pull rates only; total cost will be based on actual Disposal and/or Processing costs. Rates charged to Customers should include the total cost for pull, Processing and Disposal rates.</p> <p>Temporary Roll-offs (Non-permanent service of no more than 30 consecutive days at Customer's site): Shall be charged as accordingly to the Service Rates indicated above and may charge an additional daily rental fee (See Extra Services Fees).</p> | | | | |

*Estimated No. of Collections per Week is based on 2019 Customer data submitted by the current non-exclusive commercial franchise waste haulers. Each of the Service Areas have different Customer counts.

Additional Entry: (Proposer may use this space to add additional information such as additional facilities and if Proposer would like to add any additional service levels and Container sizes that may have not been identified above)

The undersigned Proposer offers to perform the work described in the Request for Proposals (RFP) for the following price(s). The Proposer rate(s) (hourly, monthly, etc.) shall include all administrative costs, franchise fees, labor, supervision, overtime, materials, transportation, taxes, equipment, and supplies unless stated otherwise in the RFP. The Proposer understands and agrees that the quantities set forth in the Schedule of Prices by the County are only estimates are based on current hauler submittals. Any unit prices quoted by the Proposer in this Schedule of Prices will apply to the actual quantities of work. The Proposer may use the estimates to develop its cost and rate proposal. The Proposer understands and agrees that each of the Service Areas have different Customer counts. County makes no representation or warranties of any kind, expressed or implied, as to the accuracy of the information set forth in the Schedule of Prices. County will not be liable for any damages or loss of any nature, including, but not limited to, lost profits, resulting from the estimates provided by the County. Proposer agrees to indemnify and hold the County harmless with respect to any issues, disputes, claims, lawsuits resulting from the estimates provided by the County in this solicitation, and in particular, as set forth in the Schedule of Prices. It is the responsibility of the proposer to undertake, at its sole cost, any verification of any and all information necessary for the preparation and submittal of a response to this RFP.

It is the County's sole discretion to select the collection method for each Service Area after receipt of all proposals. The County's selected collection method may not be the lowest cost collection method. The County may consider factors including but not limited to, cost per cubic yard, readiness to implement, regulatory compliance, and waste diversion potential, when deciding upon a collection method for each Service Area.

Instructions: Proposer shall enter proposed monthly rates in the blue boxes below. Proposer must submit a proposal/bid for each collection method: Three-Container, Two-Container and One-Container collection methods. Failure to do so may result in the proposal/bid being rejected as nonresponsive. All proposers should include the 14% franchise fee in their proposed rates. Proposers shall not change the numbers in Column D- Estimated No. of Collections per Week. Column E will autocalculate the Proposed Annual Amount for each service. The Proposed Total Annual Amounts for Collection Services of the County selected collection method will be used for the evaluation evaluated. Proposer is responsible for ensuring accuracy of calculations.

Additional Containers for Organic Waste

Note: The following rates apply to Residential (Single Family) Customers. These are the rates that are requested in addition to the Minimum Default Collection Service. Organic Waste rates shall be no greater than the Refuse rates. The Minimum Default Collection Service includes the equivalent of 64 gallons of weekly Organic Waste Collection Service per Customer at no additional charge.

Processing Facility Name: UNIVERSAL RESOURCE RECOVERY SANTA FE SPRINGS Rate (Per Ton): \$125.00
Backup Processing Facility Name: PUENTE HILLS MRF Rate (Per Ton): \$112.07

| Service Description | Collection Frequency (No. of Pickups per Week) | Monthly Unit Price/Rate | *Estimated No. of Collections per Week | Annual Amount (Monthly Unit Price/Rate x Estimated No. of Collections per Week x 12) |
|---------------------|--|-------------------------|--|--|
| 32-Gallon Cart | 1 | \$12.00 | | \$0.00 |
| | 2 | \$22.00 | | \$0.00 |
| | 3 | \$32.00 | | \$0.00 |
| | 4 | \$42.00 | | \$0.00 |
| | 5 | \$70.00 | | \$0.00 |
| | 6 | \$108.00 | | \$0.00 |
| | 7 | \$124.00 | | \$0.00 |
| 64-Gallon Cart | 1 | \$ 21.00 | 26 | \$6,552.00 |
| | 2 | \$ 32.00 | | \$0.00 |
| | 3 | \$ 63.00 | | \$0.00 |
| | 4 | \$ 80.00 | | \$0.00 |
| | 5 | \$ 99.00 | | \$0.00 |
| | 6 | \$ 115.00 | | \$0.00 |
| | 7 | \$ 125.00 | | \$0.00 |

| | | | | |
|--|---|----------|----|--------------------|
| 96-Gallon Cart | 1 | \$29.70 | 25 | \$8,910.00 |
| | 2 | \$56.43 | 1 | \$677.16 |
| | 3 | \$74.43 | | \$0.00 |
| | 4 | \$90.63 | | \$0.00 |
| | 5 | \$106.83 | | \$0.00 |
| | 6 | \$123.93 | | \$0.00 |
| | 7 | \$146.43 | | \$0.00 |
| 1 CY Dumpster | | | | |
| 1 CY Dumpster | 1 | \$40.50 | 78 | \$37,908.00 |
| | 2 | \$81.00 | 15 | \$14,580.00 |
| | 3 | \$121.50 | | \$0.00 |
| | 4 | \$162.00 | | \$0.00 |
| | 5 | \$202.50 | | \$0.00 |
| | 6 | \$243.00 | | \$0.00 |
| | 7 | \$283.50 | | \$0.00 |
| 1.5 CY Dumpster | | | | |
| 1.5 CY Dumpster | 1 | \$43.20 | | \$0.00 |
| | 2 | \$86.40 | | \$0.00 |
| | 3 | \$129.60 | | \$0.00 |
| | 4 | \$172.80 | | \$0.00 |
| | 5 | \$216.00 | | \$0.00 |
| | 6 | \$259.20 | | \$0.00 |
| | 7 | \$302.40 | | \$0.00 |
| 2 CY Dumpster | | | | |
| 2 CY Dumpster | 1 | \$46.80 | | \$0.00 |
| | 2 | \$93.60 | | \$0.00 |
| | 3 | \$140.40 | | \$0.00 |
| | 4 | \$187.20 | | \$0.00 |
| | 5 | \$234.00 | | \$0.00 |
| | 6 | \$280.80 | | \$0.00 |
| | 7 | \$327.60 | | \$0.00 |
| 3 CY Dumpster | | | | |
| 3 CY Dumpster | 1 | \$55.80 | | \$0.00 |
| | 2 | \$111.60 | | \$0.00 |
| | 3 | \$167.40 | | \$0.00 |
| | 4 | \$223.20 | | \$0.00 |
| | 5 | \$279.00 | | \$0.00 |
| | 6 | \$334.80 | | \$0.00 |
| | 7 | \$390.60 | | \$0.00 |
| 8 CY to 40 CY Roll-offs | | | | |
| 8 CY to 40 CY Roll-offs | 1 | \$103.50 | 2 | \$2,484.00 |
| | 2 | \$207.00 | | \$0.00 |
| | 3 | \$310.50 | | \$0.00 |
| | 4 | \$414.00 | | \$0.00 |
| | 5 | \$517.50 | | \$0.00 |
| | 6 | \$621.00 | | \$0.00 |
| | 7 | \$724.50 | | \$0.00 |
| Compactor | | | | |
| Compactor | 1 | \$107.10 | | \$0.00 |
| | 2 | \$214.20 | | \$0.00 |
| | 3 | \$321.30 | | \$0.00 |
| | 4 | \$428.40 | | \$0.00 |
| | 5 | \$535.50 | | \$0.00 |
| | 6 | \$642.60 | | \$0.00 |
| | 7 | \$749.70 | | \$0.00 |
| Total Proposed Annual Amount (3C) | | | | \$71,111.16 |

Permanent Roll-Offs and Compactors: All 8, 10, 20, 30, 40 CY Roll-offs and compactors are pull rates only; total cost will be based on actual Disposal and/or Processing costs. Rates charged to Customers should include the total cost for pull, Processing and Disposal rates.
Temporary Roll-offs (Non-permanent service of no more than 30 consecutive days at Customer's site): Shall be charged as accordingly to the Service Rates indicated above and may charge an additional daily rental fee (See Extra Services Fees).

*Estimated No. of Collections per Week is based on 2019 Customer data submitted by the current non-exclusive commercial franchise waste haulers. Each of the Service Areas have different Customer counts.

Additional Entry: *(Proposer may use this space to add additional information such as additional facilities and if Proposer would like to add any additional service levels and Container sizes that may have not been identified above)*

The undersigned Proposer offers to perform the work described in the Request for Proposals (RFP) for the following price(s). The Proposer rate(s) (hourly, monthly, etc.) shall include all administrative costs, franchise fees, labor, supervision, overtime, materials, transportation, taxes, equipment, and supplies unless stated otherwise in the RFP. The Proposer understands and agrees that the quantities set forth in the Schedule of Prices by the County are only estimates are based on current hauler submittals. Any unit prices quoted by the Proposer in this Schedule of Prices will apply to the actual quantities of work. The Proposer may use the estimates to develop its cost and rate proposal. The Proposer understands and agrees that each of the Service Areas have different Customer counts. County makes no representation or warranties of any kind, expressed or implied, as to the accuracy of the information set forth in the Schedule of Prices. County will not be liable for any damages or loss of any nature, including, but not limited to, lost profits, resulting from the estimates provided by the County. Proposer agrees to indemnify and hold the County harmless with respect to any issues, disputes, claims, lawsuits resulting from the estimates provided by the County in this solicitation, and in particular, as set forth in the Schedule of Prices. It is the responsibility of the proposer to undertake, at its sole cost, any verification of any and all information necessary for the preparation and submittal of a response to this RFP.

Instructions: Proposer shall enter a proposed rate in the blue box below. Failure to do so may result in the proposal/bid being rejected as nonresponsive.

Single Pass Collection

Note: These rates would apply to Commercial, Multifamily and Residential Customers who have been approved to receive Single-pass Collection Service. Single-Pass means that Customers may commingle and discard Refuse, Recyclables, and Organic Waste into one Collection Container, this service is subject to Director approval.

If Proposer does not currently have a facility to process Single-Pass Collection Service, Proposer shall input rates utilizing the facility tipping fee of a potential development of a High Diversion Organic Waste Processing Facility (HDOWPF) located in South Gate which will process Mixed Waste (Refuse and Organic Waste) at \$105 per ton,— OR — another High Diversion Organic Waste Processing Facility of Proposer's choosing with a reasonably similar tipping fee, location, and diversion rate that is in compliance with SB 1383 regulations as defined in 14 CCR Section 18982(a)(33).

Processing Facility Name: UNIVERSAL RESOURCE RECOVERY SANTA FE SPRINGS Rate (Tip Fee Per Ton): \$125.00

| Type of Service | Service Description | Rate |
|------------------------|--|--|
| Single Pass Collection | *See Item M of Section 4 Based on Director approval | <u>\$ Tip Fee (Per Ton) x Total Single-Pass Tonnage Collected</u> Disposal/Diversion Expense |
| | | \$3.95 Transportation/Labor Expense (Cost per mile) |

Additional Entry: *(Proposer may use this space to add additional information)*

The undersigned Proposer offers to perform the work described in the Request for Proposals (RFP) for the following price(s). The Proposer rate(s) (hourly, monthly, etc.) shall include all administrative costs, franchise fees, labor, supervision, overtime, materials, transportation, taxes, equipment, and supplies unless stated otherwise in the RFP. The Proposer understands and agrees that the quantities set forth in the Schedule of Prices by the County are only estimates are based on current hauler submittals. Any unit prices quoted by the Proposer in this Schedule of Prices will apply to the actual quantities of work. The Proposer may use the estimates to develop its cost and rate proposal. The Proposer understands and agrees that each of the Service Areas have different Customer counts. County makes no representation or warranties of any kind, expressed or implied, as to the accuracy of the information set forth in the Schedule of Prices. County will not be liable for any damages or loss of any nature, including, but not limited to, lost profits, resulting from the estimates provided by the County. Proposer agrees to indemnify and hold the County harmless with respect to any issues, disputes, claims, lawsuits resulting from the estimates provided by the County in this solicitation, and in particular, as set forth in the Schedule of Prices. It is the responsibility of the proposer to undertake, at its sole cost, any verification of any and all information necessary for the preparation and submittal of a response to this RFP.

Instructions: Proposer shall enter proposed rates for extra services to Customers in the blue boxes. Failure to do so may result in the proposal/bid being rejected as nonresponsive.

Extra Services Fees

Note: These rates apply to Commercial, Multifamily and Residential Customers.

| Extra Service | Description | Fee |
|---|--|--|
| Locks | | |
| Padlock | Upon Customer Request | \$29.99 (one-time, per Container) |
| Gravity Lock | Upon Customer Request | \$155.00 (one-time, per Container) |
| Lock Bar | Upon Customer Request | \$110.00 (one-time, per Container) |
| Service | | |
| *Roll-out | Upon Customer Request | \$17.49 Cost per Collection Event \$13.95 Cost per container (beyond first container) |
| *Scout | 25-50 ft | \$17.98 Cost per Collection Event \$14.98 Cost per container (beyond first container) |
| | 51-75 ft | \$25.90 Cost per Collection Event \$18.90 Cost per container (beyond first container) |
| | 76+ ft | \$34.99 Cost per Collection Event \$24.99 Cost per container (beyond first container) |
| *Difficult to Service | *See Difficult to Service Areas in item L of Exhibit 3A1 (If applicable to Service Area) | \$19.90 Cost per Collection Event \$15.90 Cost per container (beyond first container) |
| Additional Bulky Item picks ups for Multifamily and Residential Customers (After exceeding maximum Collections allowed per yr.) | *See Bulky Item Collection in item F1c of Exhibit 3A1 | \$65.00 per pickup |
| Additional Bulky Item picks ups for Commercial Customers (After exceeding 6 collections per yr.) | *See Bulky Item Collection in item F3a of Exhibit 3A1 | \$55.00 per pickup |

| Containers | | |
|--|--|---|
| *Bear Resistant Containers -96-Gallon Cart | Upon Customer Request | \$52.25 per month |
| *Bear Resistant Containers -Other Container size (If available): _____ | Upon Customer Request | \$49.40 per month Does not specify other size |
| *Cleaning or Exchange of Containers for cleaning purposes | *See Container Cleanings in item C4 of Exhibit 3A1 (After one free cleaning per year) | \$61.75 per Cart or Dumpster Container |
| | | \$617.50 per Compactor Container |
| | | \$403.75 per Roll-off Container |
| Extra Pickup Charge, beyond 1 per year (Unscheduled collection due to non- collection events) | *See Non-Collection in item A5 of Exhibit 3A1 | \$99.00 per occurrence |
| Container Violation Fee-For Unresponsive Customers or not rectified scenarios needing to collect Solid Waste materials subject to non-collection events | *See Non-Collection in item A5 of Exhibit 3A1 | \$99.00 Per occurrence |
| *Contamination Fee | *See Contamination Monitoring in item J1 of Exhibit 3A1 | \$65.00 Per occurrence |
| Roll-off (Excluding C&D) | Temporary Roll-off Daily Rental Fee | \$15.00 per day |
| Container Size Exchange, beyond 1 per year | *See item C7c in Exhibit 3A1 (Each additional exchange/delivery) | \$25.00 Per each additional exchange |
| Container Removal and Return within previous 12 months (Containers in Public- Right-of Way) | *See Removal of Carts or Dumpsters Stored in the Public Right-of-Way in Item C7d of Exhibit 3A1 | \$25.00 First removal and return (per set) \$ <u>Additional 25% fee</u> Each additional removal and return (per set) \$145.00 Cleanup of Set-Out Site |
| Construction and Demolition (C&D) Debris Roll-offs | | |
| C&D Roll-off Containers | Upon Customer Request | \$ <u>Negotiate rate with Customer</u> per month |
| Manure Service | | |
| 64-Gallon Cart | Upon Customer Request | \$65.00 per month |
| 1 CY Dumpster | Upon Customer Request | \$125.00 per month |
| 2 CY Dumpster | Upon Customer Request | \$139.00 per month |
| In-Home Food Waste Container | | |
| *Additional in-home Food Waste Containers | *See item A3a of Exhibit 3A1 Upon Customer Request | \$19.00 per Container |
| Green Waste Service | | |
| Green Waste only Containers (Carts and Dumpsters) | Upon Customer Request | \$ <u>Negotiate rate with Customer</u> per month |
| Billing | | |
| Late Payment Fee | *See Section 7- Service Rates and Billing | 10% of past due amount |
| Service Interruption | *See Section 7- Service Rates and Billing | \$25.00 |
| Returned Checks | *See Section 7- Service Rates and Billing | \$25.00 |

*The cost per collection event shall include the first container and the cost per container is for each additional container beyond the first.

Additional Entry: (Proposer may use this space to add additional information)

The undersigned Proposer offers to perform the work described in the Request for Proposals (RFP) for the following price(s). The Proposer rate(s) (hourly, monthly, etc.) shall include all administrative costs, franchise fees, labor, supervision, overtime, materials, transportation, taxes, equipment, and supplies unless stated otherwise in the RFP. The Proposer understands and agrees that the quantities set forth in the Schedule of Prices by the County are only estimates are based on current hauler submittals. Any unit prices quoted by the Proposer in this Schedule of Prices will apply to the actual quantities of work. The Proposer may use the estimates to develop its cost and rate proposal. The Proposer understands and agrees that each of the Service Areas have different Customer counts. County makes no representation or warranties of any kind, expressed or implied, as to the accuracy of the information set forth in the Schedule of Prices. County will not be liable for any damages or loss of any nature, including, but not limited to, lost profits, resulting from the estimates provided by the County. Proposer agrees to indemnify and hold the County harmless with respect to any issues, disputes, claims, lawsuits resulting from the estimates provided by the County in this solicitation, and in particular, as set forth in the Schedule of Prices. It is the responsibility of the proposer to undertake, at its sole cost, any verification of any and all information necessary for the preparation and submittal of a response to this RFP.

Instructions: Proposer shall enter proposed rates in the blue boxes below. Failure to do so may result in the proposal/bid being rejected as nonresponsive.

| Unlimited Bulky Item Collections for Multifamily and Residential Customers The default Bulky Item Collection Services will be Option A- Maximum Amount of Collections Per Year (Tiered Approach) *See Section F1c of Exhibit 3A1 | |
|---|---------|
| Added cost to Solid Waste Collection Services Base Rate to implement unlimited Bulky Item Collection Services | \$49.85 |

| Community Meetings | | |
|--|------------------|-------------------|
| Description of Service | Rate Information | Hourly Rate |
| Costs for Attending/Presenting at Community Meetings | Per event | \$125.00 per hour |

Additional Entry: *(Proposer may use this space to add additional information)*

Rates Summary

Note: The Total Proposed Annual Amounts from all the proposal rate sheets for Collection Services only (Solid Waste Collection Services, Additional Organics and Additional Recycling rates) will be automatically calculated into the table below. Proposer is responsible for ensuring accuracy of calculations. Proposer must fill and sign the signature block acknowledgement below upon confirming calculations.

| Title | Proposed Total Annual Amounts |
|--|-------------------------------|
| Commercial Solid Waste Collection Services Rates (1A) | \$439,898.40 |
| Commercial Additional Recycling Rates (1B) | \$244,086.00 |
| Commercial Additional Organics Rates (1C) | \$417,658.56 |
| Commercial Collection Services (1) (Total Proposed Annual Amounts of 1A+1B+1C) | \$1,101,642.96 |
| Multifamily Solid Waste Collection Services Rates (2A) | \$488,988.00 |
| Multifamily Additional Recycling Rates (2B) | \$200,112.00 |
| Multifamily Additional Organics Rates (2C) | \$334,949.04 |
| Multifamily Collection Services (2) (Total Proposed Annual Amounts of 2A+2B+2C) | \$1,024,049.04 |
| Residential Solid Waste Collection Services Rates (3A) | \$154,452.00 |
| Residential Additional Recycling Rates (3B) | \$40,942.20 |
| Residential Additional Organics Rates (3C) | \$71,111.16 |
| Residential Collection Services (3) (Total Proposed Annual Amounts of 3A+3B+3C) | \$266,505.36 |
| Total Proposed Annual Amount for Three-Container Collection Services (Total Proposed Annual Amounts of 1+2+3) | \$2,392,197.36 |

Signature Block Acknowledgement:

| | |
|---|--|
| Legal Name of Proposer: WARE DISPOSAL, INC | |
| Signature of Person Authorized to Submit Proposal: JAY WARE | |
| Title of Authorized Person: GENERAL MANAGER | |
| Date: 7-14-22 | State Contractor's License Number: CA55393 |
| Proposer's Address: 1035 E 4TH STREET SANTA ANA CA 92702 | |
| Email: JAY@WAREDISPOSAL.COM | |
| Phone: 714 664 0677 | Mobile: 714 906 2887 |

The undersigned Proposer offers to perform the work described in the Request for Proposals (RFP) for the following price(s). The Proposer rate(s) (hourly, monthly, etc.) shall include all administrative costs, franchise fees, labor, supervision, overtime, materials, transportation, taxes, equipment, and supplies unless stated otherwise in the RFP. The Proposer understands and agrees that the quantities set forth in the Schedule of Prices by the County are only estimates are based on current hauler submittals. Any unit prices quoted by the Proposer in this Schedule of Prices will apply to the actual quantities of work. The Proposer may use the estimates to develop its cost and rate proposal. The Proposer understands and agrees that each of the Service Areas have different Customer counts. County makes no representation or warranties of any kind, expressed or implied, as to the accuracy of the information set forth in the Schedule of Prices. County will not be liable for any damages or loss of any nature, including, but not limited to, lost profits, resulting from the estimates provided by the County. Proposer agrees to indemnify and hold the County harmless with respect to any issues, disputes, claims, lawsuits resulting from the estimates provided by the County in this solicitation, and in particular, as set forth in the Schedule of Prices. It is the responsibility of the proposer to undertake, at its sole cost, any verification of any and all information necessary for the preparation and submittal of a response to this RFP.

It is the County's sole discretion to select the collection method for each Service Area after receipt of all proposals. The County's selected collection method may not be the lowest cost collection method. The County may consider factors including but not limited to, cost per cubic yard, readiness to implement, regulatory compliance, and waste diversion potential, when deciding upon a collection method for each Service Area.

Instructions: Proposer shall enter proposed monthly rates in the blue boxes below. Proposer must submit a proposal/bid for each collection method: Three-Container, Two-Container and One-Container collection methods. Failure to do so may result in the proposal/bid being rejected as nonresponsive. All proposers should include the 14% franchise fee in their proposed rates. Proposers shall not change the numbers in Column D- Estimated No. of Collections per Week. Column E will auto calculate the Proposed Annual Amount for each service. The Proposed Total Annual Amounts for Collection Services of the County selected collection method will be used for the evaluation evaluated. Proposer is responsible for ensuring accuracy of calculations.

If Proposer does not currently offer the One-Container and Two-Container collection methods, Proposer shall input rates utilizing the facility tipping fee of a potential development of a High Diversion Organic Waste Processing Facility (HDOWPF) located in South Gate which will process Mixed Waste (Refuse and Organic Waste) at \$105 per ton, – OR – another High Diversion Organic Waste Processing Facility of Proposer's choosing with a reasonably similar tipping fee, location, and diversion rate that is in compliance with SB 1383 regulations as defined in 14 CCR Section 18982(a)(33). Proposer may also include in their proposal, an option to provide One-Container or Two-Container Collection Services for select Customers so long as the Proposer's proposal indicates how the results would provide similar diversion and cost effectiveness.

Commercial Mixed Waste Processing Collection Services (Two-Container A- Gray & Blue Containers)

Gray Container: Allows for the collection of Organic Waste, such as food waste and yard waste, and Refuse.

Blue Container: Limited to traditional Non-Organic Recyclables, such as bottles, and cans, and Organic Waste, such as paper and cardboard.

Note: The following rates apply to Commercial Customers for collecting Refuse and Organic Waste in the **gray container**.

Processing Facility Name: UNIVERSAL RESOURCE RECOVERY SANTA FE SPRINGS

Processing Material(s): AS DEFINED ABOVE Rate (Per Ton) \$125.00

| Service Description | Collection Frequency (No. of Pickups per Week) | Monthly Unit Price/Rate | *Estimated No. of Collections per Week | Annual Amount (Monthly Unit Price/Rate x Estimated No. of Collections per Week x 12) |
|---------------------|--|-------------------------|--|--|
| 32-Gallon Cart | 1 | \$18.19 | | \$0.00 |
| | 2 | \$33.36 | | \$0.00 |
| | 3 | \$48.52 | | \$0.00 |
| | 4 | \$63.68 | | \$0.00 |
| | 5 | \$106.13 | | \$0.00 |
| | 6 | \$163.75 | | \$0.00 |
| | 7 | \$188.01 | | \$0.00 |
| | | | | |

| | | | | |
|------------------------|---|------------|-----|--------------|
| 64-Gallon Cart | 1 | \$31.84 | | \$0.00 |
| | 2 | \$48.52 | | \$0.00 |
| | 3 | \$95.52 | | \$0.00 |
| | 4 | \$121.30 | | \$0.00 |
| | 5 | \$150.10 | | \$0.00 |
| | 6 | \$174.36 | | \$0.00 |
| | 7 | \$189.53 | | \$0.00 |
| 96-Gallon Cart | | | | |
| 96-Gallon Cart | 1 | \$50.03 | | \$0.00 |
| | 2 | \$95.07 | | \$0.00 |
| | 3 | \$125.39 | | \$0.00 |
| | 4 | \$152.68 | | \$0.00 |
| | 5 | \$179.97 | | \$0.00 |
| | 6 | \$208.78 | | \$0.00 |
| | 7 | \$246.69 | | \$0.00 |
| 1 CY Dumpster | | | | |
| 1 CY Dumpster | 1 | \$68.23 | 7 | \$5,731.32 |
| | 2 | \$136.46 | | \$0.00 |
| | 3 | \$204.69 | | \$0.00 |
| | 4 | \$272.92 | | \$0.00 |
| | 5 | \$341.15 | | \$0.00 |
| | 6 | \$409.37 | | \$0.00 |
| | 7 | \$477.60 | | \$0.00 |
| 1.5 CY Dumpster | | | | |
| 1.5 CY Dumpster | 1 | \$72.78 | 28 | \$24,454.08 |
| | 2 | \$145.56 | 1 | \$1,746.72 |
| | 3 | \$218.33 | | \$0.00 |
| | 4 | \$291.11 | | \$0.00 |
| | 5 | \$363.89 | | \$0.00 |
| | 6 | \$436.67 | | \$0.00 |
| | 7 | \$509.44 | | \$0.00 |
| 2 CY Dumpster | | | | |
| 2 CY Dumpster | 1 | \$78.84 | 53 | \$50,142.24 |
| | 2 | \$157.68 | 5 | \$9,460.80 |
| | 3 | \$236.53 | | \$0.00 |
| | 4 | \$315.37 | | \$0.00 |
| | 5 | \$394.21 | 1 | \$4,730.52 |
| | 6 | \$473.05 | | \$0.00 |
| | 7 | \$551.90 | | \$0.00 |
| 3 CY Dumpster | | | | |
| 3 CY Dumpster | 1 | \$139.49 | 134 | \$224,299.92 |
| | 2 | \$278.98 | 52 | \$174,083.52 |
| | 3 | \$418.47 | 61 | \$306,320.04 |
| | 4 | \$454.86 | 13 | \$70,958.16 |
| | 5 | \$697.45 | 3 | \$25,108.20 |
| | 6 | \$836.94 | 8 | \$80,346.24 |
| | 7 | \$976.43 | | \$0.00 |
| 4 CY Dumpster | | | | |
| 4 CY Dumpster | 1 | \$224.40 | 13 | \$35,006.40 |
| | 2 | \$448.80 | 13 | \$70,012.80 |
| | 3 | \$673.19 | 4 | \$32,313.12 |
| | 4 | \$897.59 | 1 | \$10,771.08 |
| | 5 | \$1,121.99 | 4 | \$53,855.52 |
| | 6 | \$1,346.39 | 3 | \$48,470.04 |
| | 7 | \$1,570.78 | | \$0.00 |

| | | | | |
|---|---|------------|----|-----------------------|
| 6 CY Dumpster | 1 | \$285.05 | 3 | \$10,261.80 |
| | 2 | \$570.09 | 1 | \$6,841.08 |
| | 3 | \$855.14 | 1 | \$10,261.68 |
| | 4 | \$1,140.18 | 2 | \$27,364.32 |
| | 5 | \$1,425.23 | 4 | \$68,411.04 |
| | 6 | \$1,710.27 | | \$0.00 |
| | 7 | \$1,995.32 | | \$0.00 |
| 8 CY to 40 CY Roll-offs | 1 | \$174.36 | 18 | \$37,661.76 |
| | 2 | \$348.73 | 1 | \$4,184.76 |
| | 3 | \$523.09 | | \$0.00 |
| | 4 | \$697.45 | | \$0.00 |
| | 5 | \$871.82 | | \$0.00 |
| | 6 | \$1,046.18 | | \$0.00 |
| | 7 | \$1,220.54 | | \$0.00 |
| Compactor | 1 | \$180.43 | | \$0.00 |
| | 2 | \$360.86 | | \$0.00 |
| | 3 | \$541.28 | | \$0.00 |
| | 4 | \$721.71 | | \$0.00 |
| | 5 | \$902.14 | | \$0.00 |
| | 6 | \$1,082.57 | | \$0.00 |
| | 7 | \$1,262.99 | | \$0.00 |
| Total Proposed Annual Amount (1A) | | | | \$1,392,797.16 |
| <p>Permanent Roll-Offs and Compactors: All 8, 10, 20, 30, 40 CY Roll-offs and compactors are pull rates only; total cost will be based on actual Disposal and/or Processing costs. Rates charged to Customers should include the total cost for pull, Processing and Disposal rates.</p> <p>Temporary Roll-offs (Non-permanent service of no more than 30 consecutive days at Customer's site): Shall be charged as accordingly to the Service Rates indicated above and may charge an additional daily rental fee (See Extra Services Fees).</p> | | | | |

*Estimated No. of Collections per Week is based on 2019 Customer data submitted by the current non-exclusive commercial franchise waste haulers. Each of the Service Areas have different Customer counts.

Additional Entry: (Proposer may use this space to add additional information such as additional facilities and if Proposer would like to add any additional service levels and Container sizes that may have not been identified above)

The undersigned Proposer offers to perform the work described in the Request for Proposals (RFP) for the following price(s). The Proposer rate(s) (hourly, monthly, etc.) shall include all administrative costs, franchise fees, labor, supervision, overtime, materials, transportation, taxes, equipment, and supplies unless stated otherwise in the RFP. The Proposer understands and agrees that the quantities set forth in the Schedule of Prices by the County are only estimates are based on current hauler submittals. Any unit prices quoted by the Proposer in this Schedule of Prices will apply to the actual quantities of work. The Proposer may use the estimates to develop its cost and rate proposal. The Proposer understands and agrees that each of the Service Areas have different Customer counts. County makes no representation or warranties of any kind, expressed or implied, as to the accuracy of the information set forth in the Schedule of Prices. County will not be liable for any damages or loss of any nature, including, but not limited to, lost profits, resulting from the estimates provided by the County. Proposer agrees to indemnify and hold the County harmless with respect to any issues, disputes, claims, lawsuits resulting from the estimates provided by the County in this solicitation, and in particular, as set forth in the Schedule of Prices. It is the responsibility of the proposer to undertake, at its sole cost, any verification of any and all information necessary for the preparation and submittal of a response to this RFP.

It is the County's sole discretion to select the collection method for each Service Area after receipt of all proposals. The County's selected collection method may not be the lowest cost collection method. The County may consider factors including but not limited to, cost per cubic yard, readiness to implement, regulatory compliance, and waste diversion potential, when deciding upon a collection method for each Service Area.

Instructions: Proposer shall enter proposed monthly rates in the blue boxes below. Proposer must submit a proposal/bid for each collection method: Three-Container, Two-Container and One-Container collection methods. Failure to do so may result in the proposal/bid being rejected as nonresponsive. All proposers should include the 14% franchise fee in their proposed rates. Proposers shall not change the numbers in Column D- Estimated No. of Collections per Week. Column E will auto calculate the Proposed Annual Amount for each service. The Proposed Total Annual Amounts for Collection Services of the County selected collection method will be used for the evaluation evaluated. Proposer is responsible for ensuring accuracy of calculations.

If Proposer does not currently offer the One-Container and Two-Container collection methods, Proposer shall input rates utilizing the facility tipping fee of a potential development of a High Diversion Organic Waste Processing Facility (HDOWPF) located in South Gate which will process Mixed Waste (Refuse and Organic Waste) at \$105 per ton, – OR – another High Diversion Organic Waste Processing Facility of Proposer's choosing with a reasonably similar tipping fee, location, and diversion rate that is in compliance with SB 1383 regulations as defined in 14 CCR Section 18982(a)(33). Proposer may also include in their proposal, an option to provide One-Container or Two-Container Collection Services for select Customers so long as the Proposer's proposal indicates how the results would provide similar diversion and cost effectiveness.

Commercial Mixed Waste Processing Collection Services (Two-Container A- Gray & Blue Containers)

Gray Container: Allows for the collection of Organic Waste, such as food waste and yard waste, and Refuse.

Blue Container: Limited to traditional Non-Organic Recyclables, such as bottles, and cans, and Organic Waste, such as paper and cardboard.

Note: The following rates apply to Commercial Customers for collecting Recyclables in the **blue container**.

Processing Facility Name: UNIVERSAL RESOURCE RECOVERY SANTA FE SPRINGS

Processing Material(s): AS DEFINED ABOVE Rate (Per Ton) \$125.00

| Service Description | Collection Frequency (No. of Pickups per Week) | Monthly Unit Price/Rate | *Estimated No. of Collections per Week | Annual Amount (Monthly Unit Price/Rate x Estimated No. of Collections per Week x 12) |
|---------------------|--|-------------------------|--|--|
| 32-Gallon Cart | 1 | \$18.19 | | \$0.00 |
| | 2 | \$33.36 | | \$0.00 |
| | 3 | \$48.52 | | \$0.00 |
| | 4 | \$63.68 | | \$0.00 |
| | 5 | \$106.13 | | \$0.00 |
| | 6 | \$163.75 | | \$0.00 |
| | 7 | \$188.01 | | \$0.00 |
| | | | | |

| | | | | |
|------------------------|---|------------|-----|--------------|
| 64-Gallon Cart | 1 | \$31.84 | | \$0.00 |
| | 2 | \$48.52 | | \$0.00 |
| | 3 | \$95.52 | | \$0.00 |
| | 4 | \$121.30 | | \$0.00 |
| | 5 | \$150.10 | | \$0.00 |
| | 6 | \$174.36 | | \$0.00 |
| | 7 | \$189.53 | | \$0.00 |
| 96-Gallon Cart | | | | |
| | 1 | \$50.03 | 7 | \$4,202.52 |
| | 2 | \$95.07 | | \$0.00 |
| | 3 | \$125.39 | | \$0.00 |
| | 4 | \$152.68 | | \$0.00 |
| | 5 | \$179.97 | | \$0.00 |
| | 6 | \$208.78 | | \$0.00 |
| | 7 | \$246.69 | | \$0.00 |
| 1 CY Dumpster | | | | |
| | 1 | \$68.23 | 81 | \$66,319.56 |
| | 2 | \$136.46 | 6 | \$9,825.12 |
| | 3 | \$204.69 | | \$0.00 |
| | 4 | \$272.92 | | \$0.00 |
| | 5 | \$341.15 | 1 | \$4,093.80 |
| | 6 | \$409.37 | | \$0.00 |
| | 7 | \$477.60 | | \$0.00 |
| 1.5 CY Dumpster | | | | |
| | 1 | \$72.78 | 134 | \$117,030.24 |
| | 2 | \$145.56 | 52 | \$90,829.44 |
| | 3 | \$218.33 | 61 | \$159,817.56 |
| | 4 | \$291.11 | 13 | \$45,413.16 |
| | 5 | \$363.89 | 3 | \$13,100.04 |
| | 6 | \$436.67 | 8 | \$41,920.32 |
| | 7 | \$509.44 | | \$0.00 |
| 2 CY Dumpster | | | | |
| | 1 | \$78.84 | 13 | \$12,299.04 |
| | 2 | \$157.68 | 13 | \$24,598.08 |
| | 3 | \$236.53 | 4 | \$11,353.44 |
| | 4 | \$315.37 | 1 | \$3,784.44 |
| | 5 | \$394.21 | 4 | \$18,922.08 |
| | 6 | \$473.05 | 3 | \$17,029.80 |
| | 7 | \$551.90 | | \$0.00 |
| 3 CY Dumpster | | | | |
| | 1 | \$139.49 | 3 | \$5,021.64 |
| | 2 | \$278.98 | 1 | \$3,347.76 |
| | 3 | \$418.47 | 1 | \$5,021.64 |
| | 4 | \$454.86 | 2 | \$10,916.64 |
| | 5 | \$697.45 | 4 | \$33,477.60 |
| | 6 | \$836.94 | | \$0.00 |
| | 7 | \$976.43 | | \$0.00 |
| 4 CY Dumpster | | | | |
| | 1 | \$224.40 | | \$0.00 |
| | 2 | \$448.80 | | \$0.00 |
| | 3 | \$673.19 | | \$0.00 |
| | 4 | \$897.59 | | \$0.00 |
| | 5 | \$1,121.99 | | \$0.00 |
| | 6 | \$1,346.39 | | \$0.00 |
| | 7 | \$1,570.78 | | \$0.00 |

| | | | | |
|--|---|------------|----|---------------------|
| 6 CY Dumpster | 1 | \$285.05 | | \$0.00 |
| | 2 | \$570.09 | | \$0.00 |
| | 3 | \$855.14 | | \$0.00 |
| | 4 | \$1,140.18 | | \$0.00 |
| | 5 | \$1,425.23 | | \$0.00 |
| | 6 | \$1,710.27 | | \$0.00 |
| | 7 | \$1,995.32 | | \$0.00 |
| 8 CY to 40 CY Roll-offs | | | | |
| | 1 | \$174.36 | 18 | \$37,661.76 |
| | 2 | \$348.73 | 1 | \$4,184.76 |
| | 3 | \$523.09 | | \$0.00 |
| | 4 | \$697.45 | | \$0.00 |
| | 5 | \$871.82 | | \$0.00 |
| | 6 | \$1,046.18 | | \$0.00 |
| | 7 | \$1,220.54 | | \$0.00 |
| Compactor | | | | |
| | 1 | \$180.43 | | \$0.00 |
| | 2 | \$360.86 | | \$0.00 |
| | 3 | \$541.28 | | \$0.00 |
| | 4 | \$721.71 | | \$0.00 |
| | 5 | \$902.14 | | \$0.00 |
| | 6 | \$1,082.57 | | \$0.00 |
| | 7 | \$1,262.99 | | \$0.00 |
| Total Proposed Annual Amount (1B) | | | | \$740,170.44 |

Permanent Roll-Offs and Compactors: All 8, 10, 20, 30, 40 CY Roll-offs and compactors are pull rates only; total cost will be based on actual Disposal and/or Processing costs. Rates charged to Customers should include the total cost for pull, Processing and Disposal rates.
Temporary Roll-offs (Non-permanent service of no more than 30 consecutive days at Customer's site): Shall be charged as accordingly to the Service Rates indicated above and may charge an additional daily rental fee (See Extra Services Fees).

*Estimated No. of Collections per Week is based on 2019 Customer data submitted by the current non-exclusive commercial franchise waste haulers. Each of the Service Areas have different Customer counts.

Additional Entry: (Proposer may use this space to add additional information such as additional facilities and if Proposer would like to add any additional service levels and Container sizes that may have not been identified above)

The undersigned Proposer offers to perform the work described in the Request for Proposals (RFP) for the following price(s). The Proposer rate(s) (hourly, monthly, etc.) shall include all administrative costs, franchise fees, labor, supervision, overtime, materials, transportation, taxes, equipment, and supplies unless stated otherwise in the RFP. The Proposer understands and agrees that the quantities set forth in the Schedule of Prices by the County are only estimates are based on current hauler submittals. Any unit prices quoted by the Proposer in this Schedule of Prices will apply to the actual quantities of work. The Proposer may use the estimates to develop its cost and rate proposal. The Proposer understands and agrees that each of the Service Areas have different Customer counts. County makes no representation or warranties of any kind, expressed or implied, as to the accuracy of the information set forth in the Schedule of Prices. County will not be liable for any damages or loss of any nature, including, but not limited to, lost profits, resulting from the estimates provided by the County. Proposer agrees to indemnify and hold the County harmless with respect to any issues, disputes, claims, lawsuits resulting from the estimates provided by the County in this solicitation, and in particular, as set forth in the Schedule of Prices. It is the responsibility of the proposer to undertake, at its sole cost, any verification of any and all information necessary for the preparation and submittal of a response to this RFP.

It is the County's sole discretion to select the collection method for each Service Area after receipt of all proposals. The County's selected collection method may not be the lowest cost collection method. The County may consider factors including but not limited to, cost per cubic yard, readiness to implement, regulatory compliance, and waste diversion potential, when deciding upon a collection method for each Service Area.

Instructions: Proposer shall enter proposed monthly rates in the blue boxes below. Proposer must submit a proposal/bid for each collection method: Three-Container, Two-Container and One-Container collection methods. Failure to do so may result in the proposal/bid being rejected as nonresponsive. All proposers should include the 14% franchise fee in their proposed rates. Proposers shall not change the numbers in Column D- Estimated No. of Collections per Week. Column E will auto calculate the Proposed Annual Amount for each service. The Proposed Total Annual Amounts for Collection Services of the County selected collection method will be used for the evaluation evaluated. Proposer is responsible for ensuring accuracy of calculations.

If Proposer does not currently offer the One-Container and Two-Container collection methods, Proposer shall input rates utilizing the facility tipping fee of a potential development of a High Diversion Organic Waste Processing Facility (HDOWPF) located in South Gate which will process Mixed Waste (Refuse and Organic Waste) at \$105 per ton,- OR – another High Diversion Organic Waste Processing Facility of Proposer's choosing with a reasonably similar tipping fee, location, and diversion rate that is in compliance with SB 1383 regulations as defined in 14 CCR Section 18982(a)(33). Proposer may also include in their proposal, an option to provide One-Container or Two-Container Collection Services for select Customers so long as the Proposer's proposal indicates how the results would provide similar diversion and cost effectiveness.

Commercial Mixed Waste Processing Collection Services (Two-Container B- Gray & Green Containers)

Gray Container: Allows for the collection of intentional commingled wastes including Organic Waste (paper, cardboard) and Non-Organic Recyclables (bottles and cans), and Refuse.

Green Container: Limited to only Organic Waste sent to a source separated organics facility. This includes food waste and yard waste.

Note: The following rates apply to Commercial Customers for collecting all commingled wastes & Non-Organic Recyclables in the **gray** container.

Processing Facility Name: UNIVERSAL RESOURCE RECOVERY SANTA FE SPRINGS

Processing Material(s): AS DEFINED ABOVE Rate (Per Ton) \$125.00

| Service Description | Collection Frequency (No. of Pickups per Week) | Monthly Unit Price/Rate | *Estimated No. of Collections per Week | Annual Amount (Monthly Unit Price/Rate x Estimated No. of Collections per Week x 12) |
|---------------------|--|-------------------------|--|--|
| 32-Gallon Cart | 1 | \$21.89 | | \$0.00 |
| | 2 | \$40.13 | | \$0.00 |
| | 3 | \$58.37 | | \$0.00 |
| | 4 | \$76.61 | | \$0.00 |
| | 5 | \$127.68 | | \$0.00 |
| | 6 | \$196.99 | | \$0.00 |
| | 7 | \$226.18 | | \$0.00 |
| | | | | |

| | | | | |
|------------------------|---|------------|-----|--------------|
| 64-Gallon Cart | 1 | \$38.30 | | \$0.00 |
| | 2 | \$58.37 | | \$0.00 |
| | 3 | \$114.91 | | \$0.00 |
| | 4 | \$145.92 | | \$0.00 |
| | 5 | \$180.58 | | \$0.00 |
| | 6 | \$209.76 | | \$0.00 |
| | 7 | \$228.00 | | \$0.00 |
| 96-Gallon Cart | | | | |
| 96-Gallon Cart | 1 | \$60.19 | | \$0.00 |
| | 2 | \$114.36 | | \$0.00 |
| | 3 | \$150.84 | | \$0.00 |
| | 4 | \$183.68 | | \$0.00 |
| | 5 | \$216.51 | | \$0.00 |
| | 6 | \$251.16 | | \$0.00 |
| | 7 | \$296.76 | | \$0.00 |
| 1 CY Dumpster | | | | |
| 1 CY Dumpster | 1 | \$82.08 | 7 | \$6,894.72 |
| | 2 | \$164.16 | | \$0.00 |
| | 3 | \$246.24 | | \$0.00 |
| | 4 | \$328.32 | | \$0.00 |
| | 5 | \$410.40 | | \$0.00 |
| | 6 | \$492.48 | | \$0.00 |
| | 7 | \$574.56 | | \$0.00 |
| 1.5 CY Dumpster | | | | |
| 1.5 CY Dumpster | 1 | \$87.55 | 28 | \$29,416.80 |
| | 2 | \$175.10 | 1 | \$2,101.20 |
| | 3 | \$262.66 | | \$0.00 |
| | 4 | \$350.21 | | \$0.00 |
| | 5 | \$437.76 | | \$0.00 |
| | 6 | \$525.31 | | \$0.00 |
| | 7 | \$612.86 | | \$0.00 |
| 2 CY Dumpster | | | | |
| 2 CY Dumpster | 1 | \$94.85 | 53 | \$60,324.60 |
| | 2 | \$189.70 | 5 | \$11,382.00 |
| | 3 | \$284.54 | | \$0.00 |
| | 4 | \$379.39 | | \$0.00 |
| | 5 | \$474.24 | 1 | \$5,690.88 |
| | 6 | \$569.09 | | \$0.00 |
| | 7 | \$663.94 | | \$0.00 |
| 3 CY Dumpster | | | | |
| 3 CY Dumpster | 1 | \$167.81 | 134 | \$269,838.48 |
| | 2 | \$335.62 | 52 | \$209,426.88 |
| | 3 | \$503.42 | 61 | \$368,503.44 |
| | 4 | \$547.20 | 13 | \$85,363.20 |
| | 5 | \$839.04 | 3 | \$30,205.44 |
| | 6 | \$1,006.85 | 8 | \$96,657.60 |
| | 7 | \$1,174.66 | | \$0.00 |
| 4 CY Dumpster | | | | |
| 4 CY Dumpster | 1 | \$269.95 | 13 | \$42,112.20 |
| | 2 | \$539.90 | 13 | \$84,224.40 |
| | 3 | \$809.86 | 4 | \$38,873.28 |
| | 4 | \$1,079.81 | 1 | \$12,957.72 |
| | 5 | \$1,349.76 | 4 | \$64,788.48 |
| | 6 | \$1,619.71 | 3 | \$58,309.56 |
| | 7 | \$1,889.66 | | \$0.00 |

| | | | | |
|---|---|------------|----|-----------------------|
| 6 CY Dumpster | 1 | \$342.91 | 3 | \$12,344.76 |
| | 2 | \$685.82 | 1 | \$8,229.84 |
| | 3 | \$1,028.74 | 1 | \$12,344.88 |
| | 4 | \$1,371.65 | 2 | \$32,919.60 |
| | 5 | \$1,714.56 | 4 | \$82,298.88 |
| | 6 | \$2,057.47 | | \$0.00 |
| | 7 | \$2,400.38 | | \$0.00 |
| 8 CY to 40 CY Roll-offs | 1 | \$209.76 | 18 | \$45,308.16 |
| | 2 | \$419.52 | 1 | \$5,034.24 |
| | 3 | \$629.28 | | \$0.00 |
| | 4 | \$836.04 | | \$0.00 |
| | 5 | \$1,048.80 | | \$0.00 |
| | 6 | \$1,258.56 | | \$0.00 |
| | 7 | \$1,468.32 | | \$0.00 |
| Compactor | 1 | \$217.06 | | \$0.00 |
| | 2 | \$434.11 | | \$0.00 |
| | 3 | \$651.17 | | \$0.00 |
| | 4 | \$868.22 | | \$0.00 |
| | 5 | \$1,085.28 | | \$0.00 |
| | 6 | \$1,302.34 | | \$0.00 |
| | 7 | \$1,519.39 | | \$0.00 |
| Total Proposed Annual Amount (1C) | | | | \$1,675,551.24 |
| <p>Permanent Roll-Offs and Compactors: All 8, 10, 20, 30, 40 CY Roll-offs and compactors are pull rates only; total cost will be based on actual Disposal and/or Processing costs. Rates charged to Customers should include the total cost for pull, Processing and Disposal rates.</p> <p>Temporary Roll-offs (Non-permanent service of no more than 30 consecutive days at Customer's site): Shall be charged as accordingly to the Service Rates indicated above and may charge an additional daily rental fee (See Extra Services Fees).</p> | | | | |

*Estimated No. of Collections per Week is based on 2019 Customer data submitted by the current non-exclusive commercial franchise waste haulers. Each of the Service Areas have different Customer counts.

Additional Entry: (Proposer may use this space to add additional information such as additional facilities and if Proposer would like to add any additional service levels and Container sizes that may have not been identified above)

The undersigned Proposer offers to perform the work described in the Request for Proposals (RFP) for the following price(s). The Proposer rate(s) (hourly, monthly, etc.) shall include all administrative costs, franchise fees, labor, supervision, overtime, materials, transportation, taxes, equipment, and supplies unless stated otherwise in the RFP. The Proposer understands and agrees that the quantities set forth in the Schedule of Prices by the County are only estimates are based on current hauler submittals. Any unit prices quoted by the Proposer in this Schedule of Prices will apply to the actual quantities of work. The Proposer may use the estimates to develop its cost and rate proposal. The Proposer understands and agrees that each of the Service Areas have different Customer counts. County makes no representation or warranties of any kind, expressed or implied, as to the accuracy of the information set forth in the Schedule of Prices. County will not be liable for any damages or loss of any nature, including, but not limited to, lost profits, resulting from the estimates provided by the County. Proposer agrees to indemnify and hold the County harmless with respect to any issues, disputes, claims, lawsuits resulting from the estimates provided by the County in this solicitation, and in particular, as set forth in the Schedule of Prices. It is the responsibility of the proposer to undertake, at its sole cost, any verification of any and all information necessary for the preparation and submittal of a response to this RFP.

It is the County's sole discretion to select the collection method for each Service Area after receipt of all proposals. The County's selected collection method may not be the lowest cost collection method. The County may consider factors including but not limited to, cost per cubic yard, readiness to implement, regulatory compliance, and waste diversion potential, when deciding upon a collection method for each Service Area.

Instructions: Proposer shall enter proposed monthly rates in the blue boxes below. Proposer must submit a proposal/bid for each collection method: Three-Container, Two-Container and One-Container collection methods. Failure to do so may result in the proposal/bid being rejected as nonresponsive. All proposers should include the 14% franchise fee in their proposed rates. Proposers shall not change the numbers in Column D- Estimated No. of Collections per Week. Column E will auto calculate the Proposed Annual Amount for each service. The Proposed Total Annual Amounts for Collection Services of the County selected collection method will be used for the evaluation evaluated. Proposer is responsible for ensuring accuracy of calculations.

If Proposer does not currently offer the One-Container and Two-Container collection methods, Proposer shall input rates utilizing the facility tipping fee of a potential development of a High Diversion Organic Waste Processing Facility (HDOWPF) located in South Gate which will process Mixed Waste (Refuse and Organic Waste) at \$105 per ton, – OR – another High Diversion Organic Waste Processing Facility of Proposer's choosing with a reasonably similar tipping fee, location, and diversion rate that is in compliance with SB 1383 regulations as defined in 14 CCR Section 18982(a)(33). Proposer may also include in their proposal, an option to provide One-Container or Two-Container Collection Services for select Customers so long as the Proposer's proposal indicates how the results would provide similar diversion and cost effectiveness.

Commercial Mixed Waste Processing Collection Services (Two-Container B- Gray & Green Containers)

Gray Container: Allows for the collection of intentional commingled wastes including Organic Waste (paper, cardboard) and Non-Organic Recyclables (bottles and cans), and Refuse.

Green Container: Limited to only Organic Waste sent to a source separated organics facility. This includes food waste and yard waste.

Note: The following rates apply to Commercial Customers for collecting Organic Waste in the **green container**.

Processing Facility Name: UNIVERSAL RESOURCE RECOVERY SANTA FE SPRINGS

Processing Material(s): AS DEFINED ABOVE Rate (Per Ton) \$125.00

| Service Description | Collection Frequency (No. of Pickups per Week) | Monthly Unit Price/Rate | *Estimated No. of Collections per Week | Annual Amount (Monthly Unit Price/Rate x Estimated No. of Collections per Week x 12) |
|---------------------|--|-------------------------|--|--|
| 32-Gallon Cart | 1 | \$21.89 | | \$0.00 |
| | 2 | \$40.13 | | \$0.00 |
| | 3 | \$58.37 | | \$0.00 |
| | 4 | \$76.61 | | \$0.00 |
| | 5 | \$127.68 | | \$0.00 |
| | 6 | \$196.99 | | \$0.00 |
| | 7 | \$226.18 | | \$0.00 |
| 64-Gallon Cart | 1 | \$38.30 | 31 | \$14,247.60 |
| | 2 | \$58.37 | 1 | \$700.44 |
| | 3 | \$114.91 | | \$0.00 |
| | 4 | \$145.92 | | \$0.00 |
| | 5 | \$180.58 | | \$0.00 |
| | 6 | \$209.76 | | \$0.00 |
| | 7 | \$228.00 | | \$0.00 |

| | | | | |
|-------------------------|---|------------|-----|--------------|
| 96-Gallon Cart | 1 | \$60.19 | 50 | \$36,114.00 |
| | 2 | \$114.36 | 5 | \$6,861.60 |
| | 3 | \$150.84 | | \$0.00 |
| | 4 | \$183.68 | 1 | \$2,204.16 |
| | 5 | \$216.51 | | \$0.00 |
| | 6 | \$251.16 | | \$0.00 |
| | 7 | \$296.76 | | \$0.00 |
| 1 CY Dumpster | 1 | \$82.08 | 137 | \$134,939.52 |
| | 2 | \$164.16 | 56 | \$110,315.52 |
| | 3 | \$246.24 | 52 | \$153,653.76 |
| | 4 | \$328.32 | 12 | \$47,278.08 |
| | 5 | \$410.40 | 7 | \$34,473.60 |
| | 6 | \$492.48 | 7 | \$41,368.32 |
| | 7 | \$574.56 | | \$0.00 |
| 1.5 CY Dumpster | 1 | \$87.55 | 6 | \$6,303.60 |
| | 2 | \$175.10 | 6 | \$12,607.20 |
| | 3 | \$262.66 | 3 | \$9,455.76 |
| | 4 | \$350.21 | | \$0.00 |
| | 5 | \$437.76 | 4 | \$21,012.48 |
| | 6 | \$525.31 | | \$0.00 |
| | 7 | \$612.86 | | \$0.00 |
| 2 CY Dumpster | 1 | \$94.85 | 13 | \$14,796.60 |
| | 2 | \$189.70 | 3 | \$6,829.20 |
| | 3 | \$284.54 | 10 | \$34,144.80 |
| | 4 | \$379.39 | 1 | \$4,552.68 |
| | 5 | \$474.24 | | \$0.00 |
| | 6 | \$569.09 | 2 | \$13,658.16 |
| | 7 | \$663.94 | | \$0.00 |
| 3 CY Dumpster | 1 | \$167.81 | 1 | \$2,013.72 |
| | 2 | \$335.62 | 1 | \$4,027.44 |
| | 3 | \$503.42 | 1 | \$6,041.04 |
| | 4 | \$547.20 | 3 | \$19,699.20 |
| | 5 | \$839.04 | | \$0.00 |
| | 6 | \$1,006.85 | 2 | \$24,164.40 |
| | 7 | \$1,174.66 | | \$0.00 |
| 4 CY Dumpster | 1 | \$269.95 | | \$0.00 |
| | 2 | \$539.90 | | \$0.00 |
| | 3 | \$809.86 | | \$0.00 |
| | 4 | \$1,079.81 | | \$0.00 |
| | 5 | \$1,349.76 | | \$0.00 |
| | 6 | \$1,619.71 | | \$0.00 |
| | 7 | \$1,889.66 | | \$0.00 |
| 6 CY Dumpster | 1 | \$342.91 | | \$0.00 |
| | 2 | \$685.82 | | \$0.00 |
| | 3 | \$1,028.74 | | \$0.00 |
| | 4 | \$1,371.65 | | \$0.00 |
| | 5 | \$1,714.56 | | \$0.00 |
| | 6 | \$2,057.47 | | \$0.00 |
| | 7 | \$2,400.38 | | \$0.00 |
| 8 CY to 40 CY Roll-offs | 1 | \$209.76 | | \$0.00 |
| | 2 | \$419.52 | 18 | \$90,616.32 |
| | 3 | \$629.28 | 1 | \$7,551.36 |
| | 4 | \$836.04 | | \$0.00 |
| | 5 | \$1,048.80 | | \$0.00 |
| | 6 | \$1,258.56 | | \$0.00 |
| | 7 | \$1,468.32 | | \$0.00 |

| | | | | |
|------------------|---|------------|--|--------|
| Compactor | 1 | \$217.06 | | \$0.00 |
| | 2 | \$434.11 | | \$0.00 |
| | 3 | \$651.17 | | \$0.00 |
| | 4 | \$868.22 | | \$0.00 |
| | 5 | \$1,085.28 | | \$0.00 |
| | 6 | \$1,302.34 | | \$0.00 |
| | 7 | \$1,519.39 | | \$0.00 |

| | | | | |
|--|--|--|--|---------------------|
| Total Proposed Annual Amount (1D) | | | | \$859,630.56 |
|--|--|--|--|---------------------|

Permanent Roll-Offs and Compactors: All 8, 10, 20, 30, 40 CY Roll-offs and compactors are pull rates only; total cost will be based on actual Disposal and/or Processing costs. Rates charged to Customers should include the total cost for pull, Processing and Disposal rates.

Temporary Roll-offs (Non-permanent service of no more than 30 consecutive days at Customer's site): Shall be charged as accordingly to the Service Rates indicated above and may charge an additional daily rental fee (See Extra Services Fees).

*Estimated No. of Collections per Week is based on 2019 Customer data submitted by the current non-exclusive commercial franchise waste haulers. Each of the Service Areas have different Customer counts.

Additional Entry: (Proposer may use this space to add additional information such as additional facilities and if Proposer would like to add any additional service levels and Container sizes that may have not been identified above)

The undersigned Proposer offers to perform the work described in the Request for Proposals (RFP) for the following price(s). The Proposer rate(s) (hourly, monthly, etc.) shall include all administrative costs, franchise fees, labor, supervision, overtime, materials, transportation, taxes, equipment, and supplies unless stated otherwise in the RFP. The Proposer understands and agrees that the quantities set forth in the Schedule of Prices by the County are only estimates are based on current hauler submittals. Any unit prices quoted by the Proposer in this Schedule of Prices will apply to the actual quantities of work. The Proposer may use the estimates to develop its cost and rate proposal. The Proposer understands and agrees that each of the Service Areas have different Customer counts. County makes no representation or warranties of any kind, expressed or implied, as to the accuracy of the information set forth in the Schedule of Prices. County will not be liable for any damages or loss of any nature, including, but not limited to, lost profits, resulting from the estimates provided by the County. Proposer agrees to indemnify and hold the County harmless with respect to any issues, disputes, claims, lawsuits resulting from the estimates provided by the County in this solicitation, and in particular, as set forth in the Schedule of Prices. It is the responsibility of the proposer to undertake, at its sole cost, any verification of any and all information necessary for the preparation and submittal of a response to this RFP.

It is the County's sole discretion to select the collection method for each Service Area after receipt of all proposals. The County's selected collection method may not be the lowest cost collection method. The County may consider factors including but not limited to, cost per cubic yard, readiness to implement, regulatory compliance, and waste diversion potential, when deciding upon a collection method for each Service Area.

Instructions: Proposer shall enter proposed monthly rates in the blue boxes below. Proposer must submit a proposal/bid for each collection method: Three-Container, Two-Container and One-Container collection methods. Failure to do so may result in the proposal/bid being rejected as nonresponsive. All proposers should include the 14% franchise fee in their proposed rates. Proposers shall not change the numbers in Column D- Estimated No. of Collections per Week. Column E will auto calculate the Proposed Annual Amount for each service. The Proposed Total Annual Amounts for Collection Services of the County selected collection method will be used for the evaluation evaluated. Proposer is responsible for ensuring accuracy of calculations.

If Proposer does not currently offer the One-Container and Two-Container collection methods, Proposer shall input rates utilizing the facility tipping fee of a potential development of a High Diversion Organic Waste Processing Facility (HDOWPF) located in South Gate which will process Mixed Waste (Refuse and Organic Waste) at \$105 per ton, – OR – another High Diversion Organic Waste Processing Facility of Proposer's choosing with a reasonably similar tipping fee, location, and diversion rate that is in compliance with SB 1383 regulations as defined in 14 CCR Section 18982(a)(33). Proposer may also include in their proposal, an option to provide One-Container or Two-Container Collection Services for select Customers so long as the Proposer's proposal indicates how the results would provide similar diversion and cost effectiveness.

Commercial Mixed Waste Processing Collection Services (One-Container)

Note: The following rates apply to Commercial Customers for collecting Refuse, Recycling and Organic Waste materials into a single gray container.

Processing Facility Name: UNIVERSAL RESOURCE RECOVERY SANTA FE SPRINGS
Processing Material(s): AS DEFINED ABOVE Rate (Per Ton) \$125.00

| Service Description | Collection Frequency (No. of Pickups per Week) | Monthly Unit Price/Rate | *Estimated No. of Collections per Week | Annual Amount (Monthly Unit Price/Rate x Estimated No. of Collections per Week x 12) |
|---------------------|--|-------------------------|--|--|
| 32-Gallon Cart | 1 | \$20.52 | | \$0.00 |
| | 2 | \$37.62 | | \$0.00 |
| | 3 | \$54.72 | | \$0.00 |
| | 4 | \$71.82 | | \$0.00 |
| | 5 | \$119.70 | | \$0.00 |
| | 6 | \$184.68 | | \$0.00 |
| | 7 | \$212.04 | | \$0.00 |
| 64-Gallon Cart | 1 | \$35.91 | | \$0.00 |
| | 2 | \$54.72 | | \$0.00 |
| | 3 | \$107.73 | | \$0.00 |
| | 4 | \$136.80 | | \$0.00 |
| | 5 | \$169.29 | | \$0.00 |
| | 6 | \$196.65 | | \$0.00 |
| | 7 | \$213.75 | | \$0.00 |
| 96-Gallon Cart | 1 | \$56.43 | | \$0.00 |
| | 2 | \$107.22 | | \$0.00 |
| | 3 | \$141.42 | | \$0.00 |
| | 4 | \$172.20 | | \$0.00 |
| | 5 | \$202.98 | | \$0.00 |
| | 6 | \$235.47 | | \$0.00 |
| | 7 | \$278.22 | | \$0.00 |
| 1 CY Dumpster | 1 | \$76.95 | 7 | \$6,463.80 |
| | 2 | \$153.90 | | \$0.00 |
| | 3 | \$230.85 | | \$0.00 |
| | 4 | \$307.80 | | \$0.00 |
| | 5 | \$384.75 | | \$0.00 |
| | 6 | \$461.70 | | \$0.00 |
| | 7 | \$538.68 | | \$0.00 |
| 1.5 CY Dumpster | 1 | \$82.08 | 28 | \$27,578.88 |
| | 2 | \$164.16 | 1 | \$1,969.92 |
| | 3 | \$246.24 | | \$0.00 |
| | 4 | \$328.32 | | \$0.00 |
| | 5 | \$410.40 | | \$0.00 |
| | 6 | \$492.48 | | \$0.00 |
| | 7 | \$574.56 | | \$0.00 |
| 2 CY Dumpster | 1 | \$88.92 | 53 | \$56,553.12 |
| | 2 | \$177.84 | 5 | \$10,670.40 |
| | 3 | \$266.76 | | \$0.00 |
| | 4 | \$355.68 | | \$0.00 |
| | 5 | \$444.60 | 1 | \$5,335.20 |
| | 6 | \$533.52 | | \$0.00 |
| | 7 | \$622.44 | | \$0.00 |

| | | | | |
|--|---|------------|-----|-----------------------|
| 3 CY Dumpster | 1 | \$157.32 | 134 | \$252,970.56 |
| | 2 | \$314.64 | 52 | \$196,335.36 |
| | 3 | \$471.96 | 61 | \$345,474.72 |
| | 4 | \$513.00 | 13 | \$80,028.00 |
| | 5 | \$786.60 | 3 | \$28,317.60 |
| | 6 | \$943.92 | 8 | \$90,616.32 |
| | 7 | \$1,101.24 | | \$0.00 |
| 4 CY Dumpster | 1 | \$253.08 | 13 | \$39,480.48 |
| | 2 | \$506.16 | 13 | \$78,960.96 |
| | 3 | \$759.24 | 4 | \$36,443.52 |
| | 4 | \$1,012.32 | 1 | \$12,147.84 |
| | 5 | \$1,265.40 | 4 | \$60,739.20 |
| | 6 | \$1,518.48 | 3 | \$54,665.28 |
| | 7 | \$1,771.56 | | \$0.00 |
| 6 CY Dumpster | 1 | \$321.48 | 3 | \$11,573.28 |
| | 2 | \$642.96 | 1 | \$7,715.52 |
| | 3 | \$964.44 | 1 | \$11,573.28 |
| | 4 | \$1,285.92 | 2 | \$30,862.08 |
| | 5 | \$1,607.40 | 4 | \$77,155.20 |
| | 6 | \$1,928.88 | | \$0.00 |
| | 7 | \$2,250.36 | | \$0.00 |
| 8 CY to 40 CY Roll-offs | 1 | \$196.65 | 18 | \$42,476.40 |
| | 2 | \$393.30 | 1 | \$4,719.60 |
| | 3 | \$589.95 | | \$0.00 |
| | 4 | \$786.60 | | \$0.00 |
| | 5 | \$983.25 | | \$0.00 |
| | 6 | \$1,179.90 | | \$0.00 |
| | 7 | \$1,376.55 | | \$0.00 |
| Compactor | 1 | \$203.49 | | \$0.00 |
| | 2 | \$406.98 | | \$0.00 |
| | 3 | \$610.47 | | \$0.00 |
| | 4 | \$813.96 | | \$0.00 |
| | 5 | \$1,017.45 | | \$0.00 |
| | 6 | \$1,220.94 | | \$0.00 |
| | 7 | \$1,424.43 | | \$0.00 |
| Total Proposed Annual Amount (1E) | | | | \$1,570,826.52 |

Permanent Roll-Offs and Compactors: All 8, 10, 20, 30, 40 CY Roll-offs and compactors are pull rates only; total cost will be based on actual Disposal and/or Processing costs. Rates charged to Customers should include the total cost for pull, Processing and Disposal rates.

Temporary Roll-offs (Non-permanent service of no more than 30 consecutive days at Customer's site): Shall be charged as accordingly to the Service Rates indicated above and may charge an additional daily rental fee (See Extra Services Fees).

*Estimated No. of Collections per Week is based on 2019 Customer data submitted by the current non-exclusive commercial franchise waste haulers. Each of the Service Areas have different Customer counts.

Additional Entry: (Proposer may use this space to add additional information such as additional facilities and if Proposer would like to add any additional service levels and Container sizes that may have not been identified above)

The undersigned Proposer offers to perform the work described in the Request for Proposals (RFP) for the following price(s). The Proposer rate(s) (hourly, monthly, etc.) shall include all administrative costs, franchise fees, labor, supervision, overtime, materials, transportation, taxes, equipment, and supplies unless stated otherwise in the RFP. The Proposer understands and agrees that the quantities set forth in the Schedule of Prices by the County are only estimates are based on current hauler submittals. Any unit prices quoted by the Proposer in this Schedule of Prices will apply to the actual quantities of work. The Proposer may use the estimates to develop its cost and rate proposal. The Proposer understands and agrees that each of the Service Areas have different Customer counts. County makes no representation or warranties of any kind, expressed or implied, as to the accuracy of the information set forth in the Schedule of Prices. County will not be liable for any damages or loss of any nature, including, but not limited to, lost profits, resulting from the estimates provided by the County. Proposer agrees to indemnify and hold the County harmless with respect to any issues, disputes, claims, lawsuits resulting from the estimates provided by the County in this solicitation, and in particular, as set forth in the Schedule of Prices. It is the responsibility of the proposer to undertake, at its sole cost, any verification of any and all information necessary for the preparation and submittal of a response to this RFP.

It is the County's sole discretion to select the collection method for each Service Area after receipt of all proposals. The County's selected collection method may not be the lowest cost collection method. The County may consider factors including but not limited to, cost per cubic yard, readiness to implement, regulatory compliance, and waste diversion potential, when deciding upon a collection method for each Service Area.

Instructions: Proposer shall enter proposed monthly rates in the blue boxes below. Proposer must submit a proposal/bid for each collection method: Three-Container, Two-Container and One-Container collection methods. Failure to do so may result in the proposal/bid being rejected as nonresponsive. All proposers should include the 14% franchise fee in their proposed rates. Proposers shall not change the numbers in Column D- Estimated No. of Collections per Week. Column E will auto calculate the Proposed Annual Amount for each service. The Proposed Total Annual Amounts for Collection Services of the County selected collection method will be used for the evaluation evaluated. Proposer is responsible for ensuring accuracy of calculations.

If Proposer does not currently offer the One-Container and Two-Container collection methods, Proposer shall input rates utilizing the facility tipping fee of a potential development of a High Diversion Organic Waste Processing Facility (HDOWPF) located in South Gate which will process Mixed Waste (Refuse and Organic Waste) at \$105 per ton,– OR – another High Diversion Organic Waste Processing Facility of Proposer's choosing with a reasonably similar tipping fee, location, and diversion rate that is in compliance with SB 1383 regulations as defined in 14 CCR Section 18982(a)(33). Proposer may also include in their proposal, an option to provide One-Container or Two-Container Collection Services for select Customers so long as the Proposer's proposal indicates how the results would provide similar diversion and cost effectiveness.

Multifamily Mixed Waste Processing Collection Services (Two-Container A- Gray & Blue Containers)

Gray Container: Allows for the collection of Organic Waste, such as food waste and yard waste, and Refuse.

Blue Container: Limited to traditional Non-Organic Recyclables, such as bottles, and cans, and Organic Waste, such as paper and cardboard.

Note: The following rates apply to Multifamily Customers for collecting Refuse and Organic Waste in the **gray container**.

Processing Facility Name: UNIVERSAL RESOURCE RECOVERY SANTA FE SPRINGS

Processing Material(s): AS DEFINED ABOVE Rate (Per Ton) \$125.00

| Service Description | Collection Frequency (No. of Pickups per Week) | Monthly Unit Price/Rate | *Estimated No. of Collections per Week | Annual Amount (Monthly Unit Price/Rate x Estimated No. of Collections per Week x 12) |
|---------------------|--|-------------------------|--|--|
| 32-Gallon Cart | 1 | \$18.19 | | \$0.00 |
| | 2 | \$33.36 | | \$0.00 |
| | 3 | \$48.52 | | \$0.00 |
| | 4 | \$63.68 | | \$0.00 |
| | 5 | \$106.13 | | \$0.00 |
| | 6 | \$163.75 | | \$0.00 |
| | 7 | \$188.01 | | \$0.00 |
| 64-Gallon Cart | 1 | \$31.84 | | \$0.00 |
| | 2 | \$48.52 | | \$0.00 |
| | 3 | \$95.52 | | \$0.00 |
| | 4 | \$121.30 | | \$0.00 |
| | 5 | \$150.10 | | \$0.00 |
| | 6 | \$174.36 | | \$0.00 |
| | 7 | \$189.53 | | \$0.00 |
| 96-Gallon Cart | 1 | \$50.03 | | \$0.00 |
| | 2 | \$95.07 | | \$0.00 |
| | 3 | \$125.39 | | \$0.00 |
| | 4 | \$152.68 | | \$0.00 |
| | 5 | \$179.97 | | \$0.00 |
| | 6 | \$208.78 | | \$0.00 |
| | 7 | \$246.69 | | \$0.00 |
| 1 CY Dumpster | 1 | \$68.23 | 3 | \$2,456.28 |
| | 2 | \$136.46 | | \$0.00 |
| | 3 | \$204.69 | | \$0.00 |
| | 4 | \$272.92 | | \$0.00 |
| | 5 | \$341.15 | | \$0.00 |
| | 6 | \$409.37 | | \$0.00 |
| | 7 | \$477.60 | | \$0.00 |
| 1.5 CY Dumpster | 1 | \$72.78 | 8 | \$6,986.88 |
| | 2 | \$145.56 | 2 | \$3,493.44 |
| | 3 | \$218.33 | 2 | \$5,239.92 |
| | 4 | \$291.11 | | \$0.00 |
| | 5 | \$363.89 | | \$0.00 |
| | 6 | \$436.67 | | \$0.00 |
| | 7 | \$509.44 | | \$0.00 |
| 2 CY Dumpster | 1 | \$78.84 | 18 | \$17,029.44 |
| | 2 | \$157.68 | 7 | \$13,245.12 |
| | 3 | \$236.53 | 1 | \$2,838.36 |
| | 4 | \$315.37 | 5 | \$18,922.20 |
| | 5 | \$394.21 | | \$0.00 |
| | 6 | \$473.05 | | \$0.00 |
| | 7 | \$551.90 | | \$0.00 |

| | | | | |
|---|---|------------|----|-----------------------|
| 3 CY Dumpster | 1 | \$139.49 | 90 | \$150,649.20 |
| | 2 | \$278.98 | 62 | \$207,561.12 |
| | 3 | \$418.47 | 56 | \$281,211.84 |
| | 4 | \$454.86 | 19 | \$103,708.08 |
| | 5 | \$697.45 | | \$0.00 |
| | 6 | \$836.94 | | \$0.00 |
| | 7 | \$976.43 | | \$0.00 |
| 4 CY Dumpster | | | | |
| | 1 | \$224.40 | 13 | \$35,006.40 |
| | 2 | \$448.80 | 18 | \$96,940.80 |
| | 3 | \$673.19 | 19 | \$153,487.32 |
| | 4 | \$897.59 | 11 | \$118,481.88 |
| | 5 | \$1,121.99 | | \$0.00 |
| | 6 | \$1,346.39 | | \$0.00 |
| | 7 | \$1,570.78 | | \$0.00 |
| 6 CY Dumpster | | | | |
| | 1 | \$285.05 | | \$0.00 |
| | 2 | \$570.09 | 1 | \$6,841.08 |
| | 3 | \$855.14 | | \$0.00 |
| | 4 | \$1,140.18 | | \$0.00 |
| | 5 | \$1,425.23 | | \$0.00 |
| | 6 | \$1,710.27 | | \$0.00 |
| | 7 | \$1,995.32 | | \$0.00 |
| 8 CY to 40 CY Roll-offs | | | | |
| | 1 | \$174.36 | | \$0.00 |
| | 2 | \$348.73 | | \$0.00 |
| | 3 | \$523.09 | | \$0.00 |
| | 4 | \$697.45 | | \$0.00 |
| | 5 | \$871.82 | | \$0.00 |
| | 6 | \$1,046.18 | | \$0.00 |
| | 7 | \$1,220.54 | | \$0.00 |
| Compactor | | | | |
| | 1 | \$180.43 | | \$0.00 |
| | 2 | \$360.86 | | \$0.00 |
| | 3 | \$541.28 | | \$0.00 |
| | 4 | \$721.71 | | \$0.00 |
| | 5 | \$902.14 | | \$0.00 |
| | 6 | \$1,082.57 | | \$0.00 |
| | 7 | \$1,262.99 | | \$0.00 |
| Total Proposed Annual Amount (2A) | | | | \$1,224,099.36 |
| <p>Permanent Roll-Offs and Compactors: All 8, 10, 20, 30, 40 CY Roll-offs and compactors are pull rates only; total cost will be based on actual Disposal and/or Processing costs. Rates charged to Customers should include the total cost for pull, Processing and Disposal rates.</p> <p>Temporary Roll-offs (Non-permanent service of no more than 30 consecutive days at Customer's site): Shall be charged as accordingly to the Service Rates indicated above and may charge an additional daily rental fee (See Extra Services Fees).</p> | | | | |

*Estimated No. of Collections per Week is based on 2019 Customer data submitted by the current non-exclusive commercial franchise waste haulers. Each of the Service Areas have different Customer counts.

Additional Entry: (Proposer may use this space to add additional information such as additional facilities and if Proposer would like to add any additional service levels and Container sizes that may have not been identified above)

The undersigned Proposer offers to perform the work described in the Request for Proposals (RFP) for the following price(s). The Proposer rate(s) (hourly, monthly, etc.) shall include all administrative costs, franchise fees, labor, supervision, overtime, materials, transportation, taxes, equipment, and supplies unless stated otherwise in the RFP. The Proposer understands and agrees that the quantities set forth in the Schedule of Prices by the County are only estimates are based on current hauler submittals. Any unit prices quoted by the Proposer in this Schedule of Prices will apply to the actual quantities of work. The Proposer may use the estimates to develop its cost and rate proposal. The Proposer understands and agrees that each of the Service Areas have different Customer counts. County makes no representation or warranties of any kind, expressed or implied, as to the accuracy of the information set forth in the Schedule of Prices. County will not be liable for any damages or loss of any nature, including, but not limited to, lost profits, resulting from the estimates provided by the County. Proposer agrees to indemnify and hold the County harmless with respect to any issues, disputes, claims, lawsuits resulting from the estimates provided by the County in this solicitation, and in particular, as set forth in the Schedule of Prices. It is the responsibility of the proposer to undertake, at its sole cost, any verification of any and all information necessary for the preparation and submittal of a response to this RFP.

It is the County's sole discretion to select the collection method for each Service Area after receipt of all proposals. The County's selected collection method may not be the lowest cost collection method. The County may consider factors including but not limited to, cost per cubic yard, readiness to implement, regulatory compliance, and waste diversion potential, when deciding upon a collection method for each Service Area.

Instructions: Proposer shall enter proposed monthly rates in the blue boxes below. Proposer must submit a proposal/bid for each collection method: Three-Container, Two-Container and One-Container collection methods. Failure to do so may result in the proposal/bid being rejected as nonresponsive. All proposers should include the 14% franchise fee in their proposed rates. Proposers shall not change the numbers in Column D- Estimated No. of Collections per Week. Column E will auto calculate the Proposed Annual Amount for each service. The Proposed Total Annual Amounts for Collection Services of the County selected collection method will be used for the evaluation evaluated. Proposer is responsible for ensuring accuracy of calculations.

If Proposer does not currently offer the One-Container and Two-Container collection methods, Proposer shall input rates utilizing the facility tipping fee of a potential development of a High Diversion Organic Waste Processing Facility (HDOWPF) located in South Gate which will process Mixed Waste (Refuse and Organic Waste) at \$105 per ton, – OR – another High Diversion Organic Waste Processing Facility of Proposer's choosing with a reasonably similar tipping fee, location, and diversion rate that is in compliance with SB 1383 regulations as defined in 14 CCR Section 18982(a)(33). Proposer may also include in their proposal, an option to provide One-Container or Two-Container Collection Services for select Customers so long as the Proposer's proposal indicates how the results would provide similar diversion and cost effectiveness.

Multifamily Mixed Waste Processing Collection Services (Two-Container A- Gray & Blue Containers)

Gray Container: Allows for the collection of Organic Waste, such as food waste and yard waste, and Refuse.

Blue Container: Limited to traditional Non-Organic Recyclables, such as bottles, and cans, and Organic Waste, such as paper and cardboard.

Note: The following rates apply to Multifamily Customers for collecting Recyclables in the **blue container**.

Processing Facility Name: UNIVERSAL RESOURCE RECOVERY SANTA FE SPRINGS

Processing Material(s): AS DEFINED ABOVE Rate (Per Ton) \$125.00

| Service Description | Collection Frequency (No. of Pickups per Week) | Monthly Unit Price/Rate | *Estimated No. of Collections per Week | Annual Amount (Monthly Unit Price/Rate x Estimated No. of Collections per Week x 12) |
|---------------------|--|-------------------------|--|--|
| 32-Gallon Cart | 1 | \$18.19 | | \$0.00 |
| | 2 | \$33.36 | | \$0.00 |
| | 3 | \$48.52 | | \$0.00 |
| | 4 | \$63.68 | | \$0.00 |
| | 5 | \$106.13 | | \$0.00 |
| | 6 | \$163.75 | | \$0.00 |
| | 7 | \$188.01 | | \$0.00 |
| | | | | |

| | | | | |
|-----------------|---|------------|----|--------------|
| 64-Gallon Cart | 1 | \$31.84 | | \$0.00 |
| | 2 | \$48.52 | | \$0.00 |
| | 3 | \$95.52 | | \$0.00 |
| | 4 | \$121.30 | | \$0.00 |
| | 5 | \$150.10 | | \$0.00 |
| | 6 | \$174.36 | | \$0.00 |
| | 7 | \$189.53 | | \$0.00 |
| 96-Gallon Cart | 1 | \$50.03 | 3 | \$1,801.08 |
| | 2 | \$95.07 | | \$0.00 |
| | 3 | \$125.39 | | \$0.00 |
| | 4 | \$152.68 | | \$0.00 |
| | 5 | \$179.97 | | \$0.00 |
| | 6 | \$208.78 | | \$0.00 |
| | 7 | \$246.69 | | \$0.00 |
| 1 CY Dumpster | 1 | \$68.23 | 26 | \$21,287.76 |
| | 2 | \$136.46 | 9 | \$14,737.68 |
| | 3 | \$204.69 | 3 | \$7,368.84 |
| | 4 | \$272.92 | 5 | \$16,375.20 |
| | 5 | \$341.15 | | \$0.00 |
| | 6 | \$409.37 | | \$0.00 |
| | 7 | \$477.60 | | \$0.00 |
| 1.5 CY Dumpster | 1 | \$72.78 | 90 | \$78,602.40 |
| | 2 | \$145.56 | 62 | \$108,296.64 |
| | 3 | \$218.33 | 56 | \$146,717.76 |
| | 4 | \$291.11 | 19 | \$66,373.08 |
| | 5 | \$363.89 | | \$0.00 |
| | 6 | \$436.67 | | \$0.00 |
| | 7 | \$509.44 | | \$0.00 |
| 2 CY Dumpster | 1 | \$78.84 | 13 | \$12,299.04 |
| | 2 | \$157.68 | 18 | \$34,058.88 |
| | 3 | \$236.53 | 19 | \$53,928.84 |
| | 4 | \$315.37 | 11 | \$41,628.84 |
| | 5 | \$394.21 | | \$0.00 |
| | 6 | \$473.05 | | \$0.00 |
| | 7 | \$551.90 | | \$0.00 |
| 3 CY Dumpster | 1 | \$139.49 | | \$0.00 |
| | 2 | \$278.98 | 1 | \$3,347.76 |
| | 3 | \$418.47 | | \$0.00 |
| | 4 | \$454.86 | | \$0.00 |
| | 5 | \$697.45 | | \$0.00 |
| | 6 | \$836.94 | | \$0.00 |
| | 7 | \$976.43 | | \$0.00 |
| 4 CY Dumpster | 1 | \$224.40 | | \$0.00 |
| | 2 | \$448.80 | | \$0.00 |
| | 3 | \$673.19 | | \$0.00 |
| | 4 | \$897.59 | | \$0.00 |
| | 5 | \$1,121.99 | | \$0.00 |
| | 6 | \$1,346.39 | | \$0.00 |
| | 7 | \$1,570.78 | | \$0.00 |

| | | | |
|---|---|------------|---------------------|
| 6 CY Dumpster | 1 | \$285.05 | \$0.00 |
| | 2 | \$570.09 | \$0.00 |
| | 3 | \$855.14 | \$0.00 |
| | 4 | \$1,140.18 | \$0.00 |
| | 5 | \$1,425.23 | \$0.00 |
| | 6 | \$1,710.27 | \$0.00 |
| | 7 | \$1,995.32 | \$0.00 |
| 8 CY to 40 CY Roll-offs | 1 | \$174.36 | \$0.00 |
| | 2 | \$348.73 | \$0.00 |
| | 3 | \$523.09 | \$0.00 |
| | 4 | \$697.45 | \$0.00 |
| | 5 | \$871.82 | \$0.00 |
| | 6 | \$1,046.18 | \$0.00 |
| | 7 | \$1,220.54 | \$0.00 |
| Compactor | 1 | \$180.43 | \$0.00 |
| | 2 | \$360.86 | \$0.00 |
| | 3 | \$541.28 | \$0.00 |
| | 4 | \$721.71 | \$0.00 |
| | 5 | \$902.14 | \$0.00 |
| | 6 | \$1,082.57 | \$0.00 |
| | 7 | \$1,262.99 | \$0.00 |
| Total Proposed Annual Amount (2B) | | | \$606,823.80 |
| <p>Permanent Roll-Offs and Compactors: All 8, 10, 20, 30, 40 CY Roll-offs and compactors are pull rates only; total cost will be based on actual Disposal and/or Processing costs. Rates charged to Customers should include the total cost for pull, Processing and Disposal rates.</p> <p>Temporary Roll-offs (Non-permanent service of no more than 30 consecutive days at Customer's site): Shall be charged as accordingly to the Service Rates indicated above and may charge an additional daily rental fee (See Extra Services Fees).</p> | | | |

*Estimated No. of Collections per Week is based on 2019 Customer data submitted by the current non-exclusive commercial franchise waste haulers. Each of the Service Areas have different Customer counts.

Additional Entry: (Proposer may use this space to add additional information such as additional facilities and if Proposer would like to add any additional service levels and Container sizes that may have not been identified above)

The undersigned Proposer offers to perform the work described in the Request for Proposals (RFP) for the following price(s). The Proposer rate(s) (hourly, monthly, etc.) shall include all administrative costs, franchise fees, labor, supervision, overtime, materials, transportation, taxes, equipment, and supplies unless stated otherwise in the RFP. The Proposer understands and agrees that the quantities set forth in the Schedule of Prices by the County are only estimates are based on current hauler submittals. Any unit prices quoted by the Proposer in this Schedule of Prices will apply to the actual quantities of work. The Proposer may use the estimates to develop its cost and rate proposal. The Proposer understands and agrees that each of the Service Areas have different Customer counts. County makes no representation or warranties of any kind, expressed or implied, as to the accuracy of the information set forth in the Schedule of Prices. County will not be liable for any damages or loss of any nature, including, but not limited to, lost profits, resulting from the estimates provided by the County. Proposer agrees to indemnify and hold the County harmless with respect to any issues, disputes, claims, lawsuits resulting from the estimates provided by the County in this solicitation, and in particular, as set forth in the Schedule of Prices. It is the responsibility of the proposer to undertake, at its sole cost, any verification of any and all information necessary for the preparation and submittal of a response to this RFP.

It is the County's sole discretion to select the collection method for each Service Area after receipt of all proposals. The County's selected collection method may not be the lowest cost collection method. The County may consider factors including but not limited to, cost per cubic yard, readiness to implement, regulatory compliance, and waste diversion potential, when deciding upon a collection method for each Service Area.

Instructions: Proposer shall enter proposed monthly rates in the blue boxes below. Proposer must submit a proposal/bid for each collection method: Three-Container, Two-Container and One-Container collection methods. Failure to do so may result in the proposal/bid being rejected as nonresponsive. All proposers should include the 14% franchise fee in their proposed rates. Proposers shall not change the numbers in Column D- Estimated No. of Collections per Week. Column E will auto calculate the Proposed Annual Amount for each service. The Proposed Total Annual Amounts for Collection Services of the County selected collection method will be used for the evaluation evaluated. Proposer is responsible for ensuring accuracy of calculations.

If Proposer does not currently offer the One-Container and Two-Container collection methods, Proposer shall input rates utilizing the facility tipping fee of a potential development of a High Diversion Organic Waste Processing Facility (HDOWPF) located in South Gate which will process Mixed Waste (Refuse and Organic Waste) at \$105 per ton,– OR – another High Diversion Organic Waste Processing Facility of Proposer's choosing with a reasonably similar tipping fee, location, and diversion rate that is in compliance with SB 1383 regulations as defined in 14 CCR Section 18982(a)(33). Proposer may also include in their proposal, an option to provide One-Container or Two-Container Collection Services for select Customers so long as the Proposer's proposal indicates how the results would provide similar diversion and cost effectiveness.

Multifamily Mixed Waste Processing Collection Services (Two-Container B- Gray & Green Containers)

Gray Container: Allows for the collection of intentional commingled wastes including Organic Waste (paper, cardboard) and Non-Organic Recyclables (bottles and cans), and Refuse.

Green Container: Limited to only Organic Waste sent to a source separated organics facility. This includes food waste and yard waste.

Note: The following rates apply to Multifamily Customers for collecting all commingled wastes & Non-Organic Recyclables in the **gray container**.

Processing Facility Name: UNIVERSAL RESOURCE RECOVERY SANTA FE SPRINGS

Processing Material(s): AS DEFINED ABOVE Rate (Per Ton) \$125.00

| Service Description | Collection Frequency (No. of Pickups per Week) | Monthly Unit Price/Rate | *Estimated No. of Collections per Week | Annual Amount (Monthly Unit Price/Rate x Estimated No. of Collections per Week x 12) |
|---------------------|--|-------------------------|--|--|
| 32-Gallon Cart | 1 | \$21.89 | | \$0.00 |
| | 2 | \$40.13 | | \$0.00 |
| | 3 | \$58.37 | | \$0.00 |
| | 4 | \$76.61 | | \$0.00 |
| | 5 | \$127.68 | | \$0.00 |
| | 6 | \$196.99 | | \$0.00 |
| | 7 | \$226.18 | | \$0.00 |
| | | | | |

| | | | | |
|-----------------|---|------------|----|--------------|
| 64-Gallon Cart | 1 | \$38.30 | | \$0.00 |
| | 2 | \$58.37 | | \$0.00 |
| | 3 | \$114.91 | | \$0.00 |
| | 4 | \$145.92 | | \$0.00 |
| | 5 | \$180.58 | | \$0.00 |
| | 6 | \$209.76 | | \$0.00 |
| | 7 | \$228.00 | | \$0.00 |
| 96-Gallon Cart | 1 | \$60.19 | | \$0.00 |
| | 2 | \$114.36 | | \$0.00 |
| | 3 | \$150.84 | | \$0.00 |
| | 4 | \$183.68 | | \$0.00 |
| | 5 | \$216.51 | | \$0.00 |
| | 6 | \$251.16 | | \$0.00 |
| | 7 | \$296.76 | | \$0.00 |
| 1 CY Dumpster | 1 | \$82.08 | 3 | \$2,954.88 |
| | 2 | \$164.16 | | \$0.00 |
| | 3 | \$246.24 | | \$0.00 |
| | 4 | \$328.32 | | \$0.00 |
| | 5 | \$410.40 | | \$0.00 |
| | 6 | \$492.48 | | \$0.00 |
| | 7 | \$574.56 | | \$0.00 |
| 1.5 CY Dumpster | 1 | \$87.55 | 8 | \$8,404.80 |
| | 2 | \$175.10 | 2 | \$4,202.40 |
| | 3 | \$262.66 | 2 | \$6,303.84 |
| | 4 | \$350.21 | | \$0.00 |
| | 5 | \$437.76 | | \$0.00 |
| | 6 | \$525.31 | | \$0.00 |
| | 7 | \$612.86 | | \$0.00 |
| 2 CY Dumpster | 1 | \$94.85 | 18 | \$20,487.60 |
| | 2 | \$189.70 | 7 | \$15,934.80 |
| | 3 | \$284.54 | 1 | \$3,414.48 |
| | 4 | \$379.39 | 5 | \$22,763.40 |
| | 5 | \$474.24 | | \$0.00 |
| | 6 | \$569.09 | | \$0.00 |
| | 7 | \$663.94 | | \$0.00 |
| 3 CY Dumpster | 1 | \$167.81 | 90 | \$181,234.80 |
| | 2 | \$335.62 | 62 | \$249,701.28 |
| | 3 | \$503.42 | 56 | \$338,298.24 |
| | 4 | \$547.20 | 19 | \$124,761.60 |
| | 5 | \$839.04 | | \$0.00 |
| | 6 | \$1,006.85 | | \$0.00 |
| | 7 | \$1,174.66 | | \$0.00 |
| 4 CY Dumpster | 1 | \$269.95 | 13 | \$42,112.20 |
| | 2 | \$539.90 | 18 | \$116,618.40 |
| | 3 | \$809.86 | 19 | \$184,648.08 |
| | 4 | \$1,079.81 | 11 | \$142,534.92 |
| | 5 | \$1,349.76 | | \$0.00 |
| | 6 | \$1,619.71 | | \$0.00 |
| | 7 | \$1,889.66 | | \$0.00 |

| | | | | |
|---|---|------------|---|-----------------------|
| 6 CY Dumpster | 1 | \$342.91 | | \$0.00 |
| | 2 | \$685.82 | 1 | \$8,229.84 |
| | 3 | \$1,028.74 | | \$0.00 |
| | 4 | \$1,371.65 | | \$0.00 |
| | 5 | \$1,714.56 | | \$0.00 |
| | 6 | \$2,057.47 | | \$0.00 |
| | 7 | \$2,400.38 | | \$0.00 |
| 8 CY to 40 CY Roll-offs | | | | |
| | 1 | \$209.76 | | \$0.00 |
| | 2 | \$419.52 | | \$0.00 |
| | 3 | \$629.28 | | \$0.00 |
| | 4 | \$836.04 | | \$0.00 |
| | 5 | \$1,048.80 | | \$0.00 |
| | 6 | \$1,258.56 | | \$0.00 |
| | 7 | \$1,468.32 | | \$0.00 |
| Compactor | | | | |
| | 1 | \$217.06 | | \$0.00 |
| | 2 | \$434.11 | | \$0.00 |
| | 3 | \$651.17 | | \$0.00 |
| | 4 | \$868.22 | | \$0.00 |
| | 5 | \$1,085.28 | | \$0.00 |
| | 6 | \$1,302.34 | | \$0.00 |
| | 7 | \$1,519.39 | | \$0.00 |
| Total Proposed Annual Amount (2C) | | | | \$1,472,605.56 |
| <p>Permanent Roll-Offs and Compactors: All 8, 10, 20, 30, 40 CY Roll-offs and compactors are pull rates only; total cost will be based on actual Disposal and/or Processing costs. Rates charged to Customers should include the total cost for pull, Processing and Disposal rates.</p> <p>Temporary Roll-offs (Non-permanent service of no more than 30 consecutive days at Customer's site): Shall be charged as accordingly to the Service Rates indicated above and may charge an additional daily rental fee (See Extra Services Fees).</p> | | | | |

*Estimated No. of Collections per Week is based on 2019 Customer data submitted by the current non-exclusive commercial franchise waste haulers. Each of the Service Areas have different Customer counts.

Additional Entry: (Proposer may use this space to add additional information such as additional facilities and if Proposer would like to add any additional service levels and Container sizes that may have not been identified above)

The undersigned Proposer offers to perform the work described in the Request for Proposals (RFP) for the following price(s). The Proposer rate(s) (hourly, monthly, etc.) shall include all administrative costs, franchise fees, labor, supervision, overtime, materials, transportation, taxes, equipment, and supplies unless stated otherwise in the RFP. The Proposer understands and agrees that the quantities set forth in the Schedule of Prices by the County are only estimates are based on current hauler submittals. Any unit prices quoted by the Proposer in this Schedule of Prices will apply to the actual quantities of work. The Proposer may use the estimates to develop its cost and rate proposal. The Proposer understands and agrees that each of the Service Areas have different Customer counts. County makes no representation or warranties of any kind, expressed or implied, as to the accuracy of the information set forth in the Schedule of Prices. County will not be liable for any damages or loss of any nature, including, but not limited to, lost profits, resulting from the estimates provided by the County. Proposer agrees to indemnify and hold the County harmless with respect to any issues, disputes, claims, lawsuits resulting from the estimates provided by the County in this solicitation, and in particular, as set forth in the Schedule of Prices. It is the responsibility of the proposer to undertake, at its sole cost, any verification of any and all information necessary for the preparation and submittal of a response to this RFP.

It is the County's sole discretion to select the collection method for each Service Area after receipt of all proposals. The County's selected collection method may not be the lowest cost collection method. The County may consider factors including but not limited to, cost per cubic yard, readiness to implement, regulatory compliance, and waste diversion potential, when deciding upon a collection method for each Service Area.

Instructions: Proposer shall enter proposed monthly rates in the blue boxes below. Proposer must submit a proposal/bid for each collection method: Three-Container, Two-Container and One-Container collection methods. Failure to do so may result in the proposal/bid being rejected as nonresponsive. All proposers should include the 14% franchise fee in their proposed rates. Proposers shall not change the numbers in Column D- Estimated No. of Collections per Week. Column E will auto calculate the Proposed Annual Amount for each service. The Proposed Total Annual Amounts for Collection Services of the County selected collection method will be used for the evaluation evaluated. Proposer is responsible for ensuring accuracy of calculations.

If Proposer does not currently offer the One-Container and Two-Container collection methods, Proposer shall input rates utilizing the facility tipping fee of a potential development of a High Diversion Organic Waste Processing Facility (HDOWPF) located in South Gate which will process Mixed Waste (Refuse and Organic Waste) at \$105 per ton, – OR – another High Diversion Organic Waste Processing Facility of Proposer's choosing with a reasonably similar tipping fee, location, and diversion rate that is in compliance with SB 1383 regulations as defined in 14 CCR Section 18982(a)(33). Proposer may also include in their proposal, an option to provide One-Container or Two-Container Collection Services for select Customers so long as the Proposer's proposal indicates how the results would provide similar diversion and cost effectiveness.

Multifamily Mixed Waste Processing Collection Services (Two-Container B- Gray & Green Containers)

Gray Container: Allows for the collection of intentional commingled wastes including Organic Waste (paper, cardboard) and Non-Organic Recyclables (bottles and cans), and Refuse.

Green Container: Limited to only Organic Waste sent to a source separated organics facility. This includes food waste and yard waste.

Note: The following rates apply to Multifamily Customers for collecting Organic Waste in the **green container**.

Processing Facility Name: UNIVERSAL RESOURCE RECOVERY SANTA FE SPRINGS

Processing Material(s): AS DEFINED ABOVE Rate (Per Ton) \$125.00

| Service Description | Collection Frequency (No. of Pickups per Week) | Monthly Unit Price/Rate | *Estimated No. of Collections per Week | Annual Amount (Monthly Unit Price/Rate x Estimated No. of Collections per Week x 12) |
|---------------------|--|-------------------------|--|--|
| 32-Gallon Cart | 1 | \$21.89 | | \$0.00 |
| | 2 | \$40.13 | | \$0.00 |
| | 3 | \$58.37 | | \$0.00 |
| | 4 | \$76.61 | | \$0.00 |
| | 5 | \$127.68 | | \$0.00 |
| | 6 | \$196.99 | | \$0.00 |
| | 7 | \$226.18 | | \$0.00 |
| 64-Gallon Cart | 1 | \$38.30 | 3 | \$1,378.80 |
| | 2 | \$58.37 | | \$0.00 |
| | 3 | \$114.91 | | \$0.00 |
| | 4 | \$145.92 | | \$0.00 |
| | 5 | \$180.58 | | \$0.00 |
| | 6 | \$209.76 | | \$0.00 |
| | 7 | \$228.00 | | \$0.00 |
| 96-Gallon Cart | 1 | \$60.19 | 8 | \$5,778.24 |
| | 2 | \$114.36 | 2 | \$2,744.64 |
| | 3 | \$150.84 | 2 | \$3,620.16 |
| | 4 | \$183.68 | | \$0.00 |
| | 5 | \$216.51 | | \$0.00 |
| | 6 | \$251.16 | | \$0.00 |
| | 7 | \$296.76 | | \$0.00 |
| 1 CY Dumpster | 1 | \$82.08 | 108 | \$106,375.68 |
| | 2 | \$164.16 | 69 | \$135,924.48 |
| | 3 | \$246.24 | 57 | \$168,428.16 |
| | 4 | \$328.32 | 24 | \$94,556.16 |
| | 5 | \$410.40 | | \$0.00 |
| | 6 | \$492.48 | | \$0.00 |
| | 7 | \$574.56 | | \$0.00 |
| 1.5 CY Dumpster | 1 | \$87.55 | 13 | \$13,657.80 |
| | 2 | \$175.10 | 18 | \$37,821.60 |
| | 3 | \$262.66 | 19 | \$59,886.48 |
| | 4 | \$350.21 | 11 | \$46,227.72 |
| | 5 | \$437.76 | | \$0.00 |
| | 6 | \$525.31 | | \$0.00 |
| | 7 | \$612.86 | | \$0.00 |
| 2 CY Dumpster | 1 | \$94.85 | | \$0.00 |
| | 2 | \$189.70 | 1 | \$2,276.40 |
| | 3 | \$284.54 | | \$0.00 |
| | 4 | \$379.39 | | \$0.00 |
| | 5 | \$474.24 | | \$0.00 |
| | 6 | \$569.09 | | \$0.00 |
| | 7 | \$663.94 | | \$0.00 |

| | | | | |
|--|---|------------|--|---------------------|
| 3 CY Dumpster | 1 | \$167.81 | | \$0.00 |
| | 2 | \$335.62 | | \$0.00 |
| | 3 | \$503.42 | | \$0.00 |
| | 4 | \$547.20 | | \$0.00 |
| | 5 | \$839.04 | | \$0.00 |
| | 6 | \$1,006.85 | | \$0.00 |
| | 7 | \$1,174.66 | | \$0.00 |
| 4 CY Dumpster | 1 | \$269.95 | | \$0.00 |
| | 2 | \$539.90 | | \$0.00 |
| | 3 | \$809.86 | | \$0.00 |
| | 4 | \$1,079.81 | | \$0.00 |
| | 5 | \$1,349.76 | | \$0.00 |
| | 6 | \$1,619.71 | | \$0.00 |
| | 7 | \$1,889.66 | | \$0.00 |
| 6 CY Dumpster | 1 | \$342.91 | | \$0.00 |
| | 2 | \$685.82 | | \$0.00 |
| | 3 | \$1,028.74 | | \$0.00 |
| | 4 | \$1,371.65 | | \$0.00 |
| | 5 | \$1,714.56 | | \$0.00 |
| | 6 | \$2,057.47 | | \$0.00 |
| | 7 | \$2,400.38 | | \$0.00 |
| 8 CY to 40 CY Roll-offs | 1 | \$209.76 | | \$0.00 |
| | 2 | \$419.52 | | \$0.00 |
| | 3 | \$629.28 | | \$0.00 |
| | 4 | \$836.04 | | \$0.00 |
| | 5 | \$1,048.80 | | \$0.00 |
| | 6 | \$1,258.56 | | \$0.00 |
| | 7 | \$1,468.32 | | \$0.00 |
| Compactor | 1 | \$217.06 | | \$0.00 |
| | 2 | \$434.11 | | \$0.00 |
| | 3 | \$651.17 | | \$0.00 |
| | 4 | \$868.22 | | \$0.00 |
| | 5 | \$1,085.28 | | \$0.00 |
| | 6 | \$1,302.34 | | \$0.00 |
| | 7 | \$1,519.39 | | \$0.00 |
| Total Proposed Annual Amount (2D) | | | | \$678,676.32 |

Permanent Roll-Offs and Compactors: All 8, 10, 20, 30, 40 CY Roll-offs and compactors are pull rates only; total cost will be based on actual Disposal and/or Processing costs. Rates charged to Customers should include the total cost for pull, Processing and Disposal rates.

Temporary Roll-offs (Non-permanent service of no more than 30 consecutive days at Customer's site): Shall be charged as accordingly to the Service Rates indicated above and may charge an additional daily rental fee (See Extra Services Fees).

*Estimated No. of Collections per Week is based on 2019 Customer data submitted by the current non-exclusive commercial franchise waste haulers. Each of the Service Areas have different Customer counts.

Additional Entry: (Proposer may use this space to add additional information such as additional facilities and if Proposer would like to add any additional service levels and Container sizes that may have not been identified above)

FORM PW-3.5.1 Schedule of Prices
Exclusive Commercial Franchise Services
Service Area: San Gabriel Valley West

Proposer Name: WARE DISPOSAL INC.

The undersigned Proposer offers to perform the work described in the Request for Proposals (RFP) for the following price(s). The Proposer rate(s) (hourly, monthly, etc.) shall include all administrative costs, franchise fees, labor, supervision, overtime, materials, transportation, taxes, equipment, and supplies unless stated otherwise in the RFP. The Proposer understands and agrees that the quantities set forth in the Schedule of Prices by the County are only estimates are based on current hauler submittals. Any unit prices quoted by the Proposer in this Schedule of Prices will apply to the actual quantities of work. The Proposer may use the estimates to develop its cost and rate proposal. The Proposer understands and agrees that each of the Service Areas have different Customer counts. County makes no representation or warranties of any kind, expressed or implied, as to the accuracy of the information set forth in the Schedule of Prices. County will not be liable for any damages or loss of any nature, including, but not limited to, lost profits, resulting from the estimates provided by the County. Proposer agrees to indemnify and hold the County harmless with respect to any issues, disputes, claims, lawsuits resulting from the estimates provided by the County in this solicitation, and in particular, as set forth in the Schedule of Prices. It is the responsibility of the proposer to undertake, at its sole cost, any verification of any and all information necessary for the preparation and submittal of a response to this RFP.

It is the County's sole discretion to select the collection method for each Service Area after receipt of all proposals. The County's selected collection method may not be the lowest cost collection method. The County may consider factors including but not limited to, cost per cubic yard, readiness to implement, regulatory compliance, and waste diversion potential, when deciding upon a collection method for each Service Area.

Instructions: Proposer shall enter proposed monthly rates in the blue boxes below. Proposer must submit a proposal/bid for each collection method: Three-Container, Two-Container and One-Container collection methods. Failure to do so may result in the proposal/bid being rejected as nonresponsive. All proposers should include the 14% franchise fee in their proposed rates. Proposers shall not change the numbers in Column D- Estimated No. of Collections per Week. Column E will auto calculate the Proposed Annual Amount for each service. The Proposed Total Annual Amounts for Collection Services of the County selected collection method will be used for the evaluation evaluated. Proposer is responsible for ensuring accuracy of calculations.

If Proposer does not currently offer the One-Container and Two-Container collection methods, Proposer shall input rates utilizing the facility tipping fee of a potential development of a High Diversion Organic Waste Processing Facility (HDOWPF) located in South Gate which will process Mixed Waste (Refuse and Organic Waste) at \$105 per ton,- OR – another High Diversion Organic Waste Processing Facility of Proposer's choosing with a reasonably similar tipping fee, location, and diversion rate that is in compliance with SB 1383 regulations as defined in 14 CCR Section 18982(a)(33). Proposer may also include in their proposal, an option to provide One-Container or Two-Container Collection Services for select Customers so long as the Proposer's proposal indicates how the results would provide similar diversion and cost effectiveness.

Multifamily Mixed Waste Processing Collection Services (One-Container)

Note: The following rates apply to Multifamily Customers for collecting Refuse, Recycling and Organic Waste materials into a single gray container.

Processing Facility Name: UNIVERSAL RESOURCE RECOVERY SANTA FE SPRINGS
Processing Material(s): AS DEFINED ABOVE Rate (Per Ton) \$125.00

| Service Description | Collection Frequency (No. of Pickups per Week) | Monthly Unit Price/Rate | *Estimated No. of Collections per Week | Annual Amount (Monthly Unit Price/Rate x Estimated No. of Collections per Week x 12) |
|---------------------|--|-------------------------|--|--|
| 32-Gallon Cart | 1 | \$20.52 | | \$0.00 |
| | 2 | \$37.62 | | \$0.00 |
| | 3 | \$54.72 | | \$0.00 |
| | 4 | \$71.82 | | \$0.00 |
| | 5 | \$119.70 | | \$0.00 |
| | 6 | \$184.68 | | \$0.00 |
| | 7 | \$212.04 | | \$0.00 |
| | | | | |

| | | | | |
|------------------------|---|------------|----|--------------|
| 64-Gallon Cart | 1 | \$35.91 | | \$0.00 |
| | 2 | \$54.72 | | \$0.00 |
| | 3 | \$107.73 | | \$0.00 |
| | 4 | \$136.80 | | \$0.00 |
| | 5 | \$169.29 | | \$0.00 |
| | 6 | \$196.65 | | \$0.00 |
| | 7 | \$213.75 | | \$0.00 |
| 96-Gallon Cart | | | | |
| | 1 | \$56.43 | | \$0.00 |
| | 2 | \$107.22 | | \$0.00 |
| | 3 | \$141.42 | | \$0.00 |
| | 4 | \$172.20 | | \$0.00 |
| | 5 | \$202.98 | | \$0.00 |
| | 6 | \$235.47 | | \$0.00 |
| | 7 | \$278.22 | | \$0.00 |
| 1 CY Dumpster | | | | |
| | 1 | \$76.95 | 1 | \$923.40 |
| | 2 | \$153.90 | | \$0.00 |
| | 3 | \$230.85 | | \$0.00 |
| | 4 | \$307.80 | | \$0.00 |
| | 5 | \$384.75 | | \$0.00 |
| | 6 | \$461.70 | | \$0.00 |
| | 7 | \$538.68 | | \$0.00 |
| 1.5 CY Dumpster | | | | |
| | 1 | \$82.08 | 25 | \$24,624.00 |
| | 2 | \$164.16 | | \$0.00 |
| | 3 | \$246.24 | | \$0.00 |
| | 4 | \$328.32 | | \$0.00 |
| | 5 | \$410.40 | | \$0.00 |
| | 6 | \$492.48 | | \$0.00 |
| | 7 | \$574.56 | | \$0.00 |
| 2 CY Dumpster | | | | |
| | 1 | \$88.92 | 25 | \$26,676.00 |
| | 2 | \$177.84 | 1 | \$2,134.08 |
| | 3 | \$266.76 | | \$0.00 |
| | 4 | \$355.68 | | \$0.00 |
| | 5 | \$444.60 | | \$0.00 |
| | 6 | \$533.52 | | \$0.00 |
| | 7 | \$622.44 | | \$0.00 |
| 3 CY Dumpster | | | | |
| | 1 | \$157.32 | 77 | \$145,363.68 |
| | 2 | \$314.64 | 15 | \$56,635.20 |
| | 3 | \$471.96 | | \$0.00 |
| | 4 | \$513.00 | | \$0.00 |
| | 5 | \$786.60 | | \$0.00 |
| | 6 | \$943.92 | | \$0.00 |
| | 7 | \$1,101.24 | | \$0.00 |
| 4 CY Dumpster | | | | |
| | 1 | \$253.08 | 1 | \$3,036.96 |
| | 2 | \$506.16 | | \$0.00 |
| | 3 | \$759.24 | | \$0.00 |
| | 4 | \$1,012.32 | | \$0.00 |
| | 5 | \$1,265.40 | | \$0.00 |
| | 6 | \$1,518.48 | | \$0.00 |
| | 7 | \$1,771.56 | | \$0.00 |

| | | | | |
|--|---|------------|---|---------------------|
| 6 CY Dumpster | 1 | \$321.48 | | \$0.00 |
| | 2 | \$642.96 | | \$0.00 |
| | 3 | \$964.44 | | \$0.00 |
| | 4 | \$1,285.92 | | \$0.00 |
| | 5 | \$1,607.40 | | \$0.00 |
| | 6 | \$1,928.88 | | \$0.00 |
| | 7 | \$2,250.36 | | \$0.00 |
| 8 CY to 40 CY Roll-offs | | | | |
| | 1 | \$196.65 | 2 | \$4,719.60 |
| | 2 | \$393.30 | | \$0.00 |
| | 3 | \$589.95 | | \$0.00 |
| | 4 | \$786.60 | | \$0.00 |
| | 5 | \$983.25 | | \$0.00 |
| | 6 | \$1,179.90 | | \$0.00 |
| | 7 | \$1,376.55 | | \$0.00 |
| Compactor | | | | |
| | 1 | \$203.49 | | \$0.00 |
| | 2 | \$406.98 | | \$0.00 |
| | 3 | \$610.47 | | \$0.00 |
| | 4 | \$813.96 | | \$0.00 |
| | 5 | \$1,017.45 | | \$0.00 |
| | 6 | \$1,220.94 | | \$0.00 |
| | 7 | \$1,424.43 | | \$0.00 |
| Total Proposed Annual Amount (2E) | | | | \$264,112.92 |

Permanent Roll-Offs and Compactors: All 8, 10, 20, 30, 40 CY Roll-offs and compactors are pull rates only; total cost will be based on actual Disposal and/or Processing costs. Rates charged to Customers should include the total cost for pull, Processing and Disposal rates.

Temporary Roll-offs (Non-permanent service of no more than 30 consecutive days at Customer's site): Shall be charged as accordingly to the Service Rates indicated above and may charge an additional daily rental fee (See Extra Services Fees).

*Estimated No. of Collections per Week is based on 2019 Customer data submitted by the current non-exclusive commercial franchise waste haulers. Each of the Service Areas have different Customer counts.

Additional Entry: (Proposer may use this space to add additional information such as additional facilities and if Proposer would like to add any additional service levels and Container sizes that may have not been identified above)

The undersigned Proposer offers to perform the work described in the Request for Proposals (RFP) for the following price(s). The Proposer rate(s) (hourly, monthly, etc.) shall include all administrative costs, franchise fees, labor, supervision, overtime, materials, transportation, taxes, equipment, and supplies unless stated otherwise in the RFP. The Proposer understands and agrees that the quantities set forth in the Schedule of Prices by the County are only estimates are based on current hauler submittals. Any unit prices quoted by the Proposer in this Schedule of Prices will apply to the actual quantities of work. The Proposer may use the estimates to develop its cost and rate proposal. The Proposer understands and agrees that each of the Service Areas have different Customer counts. County makes no representation or warranties of any kind, expressed or implied, as to the accuracy of the information set forth in the Schedule of Prices. County will not be liable for any damages or loss of any nature, including, but not limited to, lost profits, resulting from the estimates provided by the County. Proposer agrees to indemnify and hold the County harmless with respect to any issues, disputes, claims, lawsuits resulting from the estimates provided by the County in this solicitation, and in particular, as set forth in the Schedule of Prices. It is the responsibility of the proposer to undertake, at its sole cost, any verification of any and all information necessary for the preparation and submittal of a response to this RFP.

It is the County's sole discretion to select the collection method for each Service Area after receipt of all proposals. The County's selected collection method may not be the lowest cost collection method. The County may consider factors including but not limited to, cost per cubic yard, readiness to implement, regulatory compliance, and waste diversion potential, when deciding upon a collection method for each Service Area.

Instructions: Proposer shall enter proposed monthly rates in the blue boxes below. Proposer must submit a proposal/bid for each collection method: Three-Container, Two-Container and One-Container collection methods. Failure to do so may result in the proposal/bid being rejected as nonresponsive. All proposers should include the 14% franchise fee in their proposed rates. Proposers shall not change the numbers in Column D- Estimated No. of Collections per Week. Column E will auto calculate the Proposed Annual Amount for each service. The Proposed Total Annual Amounts for Collection Services of the County selected collection method will be used for the evaluation evaluated. Proposer is responsible for ensuring accuracy of calculations.

If Proposer does not currently offer the One-Container and Two-Container collection methods, Proposer shall input rates utilizing the facility tipping fee of a potential development of a High Diversion Organic Waste Processing Facility (HDOWPF) located in South Gate which will process Mixed Waste (Refuse and Organic Waste) at \$105 per ton, – OR – another High Diversion Organic Waste Processing Facility of Proposer's choosing with a reasonably similar tipping fee, location, and diversion rate that is in compliance with SB 1383 regulations as defined in 14 CCR Section 18982(a)(33). Proposer may also include in their proposal, an option to provide One-Container or Two-Container Collection Services for select Customers so long as the Proposer's proposal indicates how the results would provide similar diversion and cost effectiveness.

Residential Mixed Waste Processing Collection Services (Two-Container A- Gray & Blue Containers)

Gray Container: Allows for the collection of Organic Waste, such as food waste and yard waste, and Refuse.

Blue Container: Limited to traditional Non-Organic Recyclables, such as bottles, and cans, and Organic Waste, such as paper and cardboard.

Note: The following rates apply to Residential Customers for collecting Refuse and Organic Waste in the **gray container**.

Processing Facility Name: UNIVERSAL RESOURCE RECOVERY
Processing Material(s): AS DEFINED ABOVE Rate (Per Ton) \$125.00

| Service Description | Collection Frequency (No. of Pickups per Week) | Monthly Unit Price/Rate | *Estimated No. of Collections per Week | Annual Amount (Monthly Unit Price/Rate x Estimated No. of Collections per Week x 12) |
|---------------------|--|-------------------------|--|--|
| 32-Gallon Cart | 1 | \$18.19 | | \$0.00 |
| | 2 | \$33.36 | | \$0.00 |
| | 3 | \$48.52 | | \$0.00 |
| | 4 | \$63.68 | | \$0.00 |
| | 5 | \$106.13 | | \$0.00 |
| | 6 | \$163.75 | | \$0.00 |
| | 7 | \$188.01 | | \$0.00 |
| 64-Gallon Cart | 1 | \$31.84 | | \$0.00 |
| | 2 | \$48.52 | | \$0.00 |
| | 3 | \$95.52 | | \$0.00 |
| | 4 | \$121.30 | | \$0.00 |
| | 5 | \$150.10 | | \$0.00 |
| | 6 | \$174.36 | | \$0.00 |
| | 7 | \$189.53 | | \$0.00 |
| 96-Gallon Cart | 1 | \$50.03 | | \$0.00 |
| | 2 | \$95.07 | | \$0.00 |
| | 3 | \$125.39 | | \$0.00 |
| | 4 | \$152.68 | | \$0.00 |
| | 5 | \$179.97 | | \$0.00 |
| | 6 | \$208.78 | | \$0.00 |
| | 7 | \$246.69 | | \$0.00 |
| 1 CY Dumpster | 1 | \$68.23 | | \$0.00 |
| | 2 | \$136.46 | | \$0.00 |
| | 3 | \$204.69 | | \$0.00 |
| | 4 | \$272.92 | | \$0.00 |
| | 5 | \$341.15 | | \$0.00 |
| | 6 | \$409.37 | | \$0.00 |
| | 7 | \$477.60 | | \$0.00 |
| 1.5 CY Dumpster | 1 | \$72.78 | | \$0.00 |
| | 2 | \$145.56 | | \$0.00 |
| | 3 | \$218.33 | | \$0.00 |
| | 4 | \$291.11 | | \$0.00 |
| | 5 | \$363.89 | | \$0.00 |
| | 6 | \$436.67 | | \$0.00 |
| | 7 | \$509.44 | | \$0.00 |
| 2 CY Dumpster | 1 | \$78.84 | | \$0.00 |
| | 2 | \$157.68 | | \$0.00 |
| | 3 | \$236.53 | | \$0.00 |
| | 4 | \$315.37 | | \$0.00 |
| | 5 | \$394.21 | | \$0.00 |
| | 6 | \$473.05 | | \$0.00 |
| | 7 | \$551.90 | | \$0.00 |

| | | | | |
|--|---|------------|--|---------------|
| 3 CY Dumpster | 1 | \$139.49 | | \$0.00 |
| | 2 | \$278.98 | | \$0.00 |
| | 3 | \$418.47 | | \$0.00 |
| | 4 | \$454.86 | | \$0.00 |
| | 5 | \$697.45 | | \$0.00 |
| | 6 | \$836.94 | | \$0.00 |
| | 7 | \$976.43 | | \$0.00 |
| 4 CY Dumpster | 1 | \$224.40 | | \$0.00 |
| | 2 | \$448.80 | | \$0.00 |
| | 3 | \$673.19 | | \$0.00 |
| | 4 | \$897.59 | | \$0.00 |
| | 5 | \$1,121.99 | | \$0.00 |
| | 6 | \$1,346.39 | | \$0.00 |
| | 7 | \$1,570.78 | | \$0.00 |
| 6 CY Dumpster | 1 | \$285.05 | | \$0.00 |
| | 2 | \$570.09 | | \$0.00 |
| | 3 | \$855.14 | | \$0.00 |
| | 4 | \$1,140.18 | | \$0.00 |
| | 5 | \$1,425.23 | | \$0.00 |
| | 6 | \$1,710.27 | | \$0.00 |
| | 7 | \$1,995.32 | | \$0.00 |
| 8 CY to 40 CY Roll-offs | 1 | \$174.36 | | \$0.00 |
| | 2 | \$348.73 | | \$0.00 |
| | 3 | \$523.09 | | \$0.00 |
| | 4 | \$697.45 | | \$0.00 |
| | 5 | \$871.82 | | \$0.00 |
| | 6 | \$1,046.18 | | \$0.00 |
| | 7 | \$1,220.54 | | \$0.00 |
| Compactor | 1 | \$180.43 | | \$0.00 |
| | 2 | \$360.86 | | \$0.00 |
| | 3 | \$541.28 | | \$0.00 |
| | 4 | \$721.71 | | \$0.00 |
| | 5 | \$902.14 | | \$0.00 |
| | 6 | \$1,082.57 | | \$0.00 |
| | 7 | \$1,262.99 | | \$0.00 |
| Total Proposed Annual Amount (3A) | | | | \$0.00 |

Permanent Roll-Offs and Compactors: All 8, 10, 20, 30, 40 CY Roll-offs and compactors are pull rates only; total cost will be based on actual Disposal and/or Processing costs. Rates charged to Customers should include the total cost for pull, Processing and Disposal rates.
Temporary Roll-offs (Non-permanent service of no more than 30 consecutive days at Customer's site): Shall be charged as accordingly to the Service Rates indicated above and may charge an additional daily rental fee (See Extra Services Fees).

*Estimated No. of Collections per Week is based on 2019 Customer data submitted by the current non-exclusive commercial franchise waste haulers. Each of the Service Areas have different Customer counts.

Additional Entry: (Proposer may use this space to add additional information such as additional facilities and if Proposer would like to add any additional service levels and Container sizes that may have not been identified above)

The undersigned Proposer offers to perform the work described in the Request for Proposals (RFP) for the following price(s). The Proposer rate(s) (hourly, monthly, etc.) shall include all administrative costs, franchise fees, labor, supervision, overtime, materials, transportation, taxes, equipment, and supplies unless stated otherwise in the RFP. The Proposer understands and agrees that the quantities set forth in the Schedule of Prices by the County are only estimates are based on current hauler submittals. Any unit prices quoted by the Proposer in this Schedule of Prices will apply to the actual quantities of work. The Proposer may use the estimates to develop its cost and rate proposal. The Proposer understands and agrees that each of the Service Areas have different Customer counts. County makes no representation or warranties of any kind, expressed or implied, as to the accuracy of the information set forth in the Schedule of Prices. County will not be liable for any damages or loss of any nature, including, but not limited to, lost profits, resulting from the estimates provided by the County. Proposer agrees to indemnify and hold the County harmless with respect to any issues, disputes, claims, lawsuits resulting from the estimates provided by the County in this solicitation, and in particular, as set forth in the Schedule of Prices. It is the responsibility of the proposer to undertake, at its sole cost, any verification of any and all information necessary for the preparation and submittal of a response to this RFP.

It is the County's sole discretion to select the collection method for each Service Area after receipt of all proposals. The County's selected collection method may not be the lowest cost collection method. The County may consider factors including but not limited to, cost per cubic yard, readiness to implement, regulatory compliance, and waste diversion potential, when deciding upon a collection method for each Service Area.

Instructions: Proposer shall enter proposed monthly rates in the blue boxes below. Proposer must submit a proposal/bid for each collection method: Three-Container, Two-Container and One-Container collection methods. Failure to do so may result in the proposal/bid being rejected as nonresponsive. All proposers should include the 14% franchise fee in their proposed rates. Proposers shall not change the numbers in Column D- Estimated No. of Collections per Week. Column E will auto calculate the Proposed Annual Amount for each service. The Proposed Total Annual Amounts for Collection Services of the County selected collection method will be used for the evaluation evaluated. Proposer is responsible for ensuring accuracy of calculations.

If Proposer does not currently offer the One-Container and Two-Container collection methods, Proposer shall input rates utilizing the facility tipping fee of a potential development of a High Diversion Organic Waste Processing Facility (HDOWPF) located in South Gate which will process Mixed Waste (Refuse and Organic Waste) at \$105 per ton, – OR – another High Diversion Organic Waste Processing Facility of Proposer's choosing with a reasonably similar tipping fee, location, and diversion rate that is in compliance with SB 1383 regulations as defined in 14 CCR Section 18982(a)(33). Proposer may also include in their proposal, an option to provide One-Container or Two-Container Collection Services for select Customers so long as the Proposer's proposal indicates how the results would provide similar diversion and cost effectiveness.

Residential Mixed Waste Processing Collection Services (Two-Container A- Gray & Blue Containers)

Gray Container: Allows for the collection of Organic Waste, such as food waste and yard waste, and Refuse.

Blue Container: Limited to traditional Non-Organic Recyclables, such as bottles, and cans, and Organic Waste, such as paper and cardboard.

Note: The following rates apply to Residential Customers for collecting Recyclables in the **blue container**.

Processing Facility Name: UNIVERSAL RESOURCE RECOVERY SANTA FE SPRINGS

Processing Material(s): AS DEFINED ABOVE Rate (Per Ton) \$125.00

| Service Description | Collection Frequency (No. of Pickups per Week) | Monthly Unit Price/Rate | *Estimated No. of Collections per Week | Annual Amount (Monthly Unit Price/Rate x Estimated No. of Collections per Week x 12) |
|---------------------|--|-------------------------|--|--|
| 32-Gallon Cart | 1 | \$18.19 | | \$0.00 |
| | 2 | \$33.36 | | \$0.00 |
| | 3 | \$48.52 | | \$0.00 |
| | 4 | \$63.68 | | \$0.00 |
| | 5 | \$106.13 | | \$0.00 |
| | 6 | \$163.75 | | \$0.00 |
| | 7 | \$188.01 | | \$0.00 |
| 64-Gallon Cart | 1 | \$31.84 | 1 | \$382.08 |
| | 2 | \$48.52 | | \$0.00 |
| | 3 | \$95.52 | | \$0.00 |
| | 4 | \$121.30 | | \$0.00 |
| | 5 | \$150.10 | | \$0.00 |
| | 6 | \$174.36 | | \$0.00 |
| | 7 | \$189.53 | | \$0.00 |
| 96-Gallon Cart | 1 | \$50.03 | 50 | \$30,018.00 |
| | 2 | \$95.07 | 1 | \$1,140.84 |
| | 3 | \$125.39 | | \$0.00 |
| | 4 | \$152.68 | | \$0.00 |
| | 5 | \$179.97 | | \$0.00 |
| | 6 | \$208.78 | | \$0.00 |
| | 7 | \$246.69 | | \$0.00 |

| | | | | |
|--|---|------------|----|---------------------|
| | | | | |
| 1 CY Dumpster | 1 | \$68.23 | 78 | \$63,863.28 |
| | 2 | \$136.46 | 15 | \$24,562.80 |
| | 3 | \$204.69 | | \$0.00 |
| | 4 | \$272.92 | | \$0.00 |
| | 5 | \$341.15 | | \$0.00 |
| | 6 | \$409.37 | | \$0.00 |
| | 7 | \$477.60 | | \$0.00 |
| 1.5 CY Dumpster | 1 | \$72.78 | | \$0.00 |
| | 2 | \$145.56 | | \$0.00 |
| | 3 | \$218.33 | | \$0.00 |
| | 4 | \$291.11 | | \$0.00 |
| | 5 | \$363.89 | | \$0.00 |
| | 6 | \$436.67 | | \$0.00 |
| | 7 | \$509.44 | | \$0.00 |
| 2 CY Dumpster | 1 | \$78.84 | | \$0.00 |
| | 2 | \$157.68 | | \$0.00 |
| | 3 | \$236.53 | | \$0.00 |
| | 4 | \$315.37 | | \$0.00 |
| | 5 | \$394.21 | | \$0.00 |
| | 6 | \$473.05 | | \$0.00 |
| | 7 | \$551.90 | | \$0.00 |
| 3 CY Dumpster | 1 | \$139.49 | | \$0.00 |
| | 2 | \$278.98 | | \$0.00 |
| | 3 | \$418.47 | | \$0.00 |
| | 4 | \$454.86 | | \$0.00 |
| | 5 | \$697.45 | | \$0.00 |
| | 6 | \$836.94 | | \$0.00 |
| | 7 | \$976.43 | | \$0.00 |
| 4 CY Dumpster | 1 | \$224.40 | | \$0.00 |
| | 2 | \$448.80 | | \$0.00 |
| | 3 | \$673.19 | | \$0.00 |
| | 4 | \$897.59 | | \$0.00 |
| | 5 | \$1,121.99 | | \$0.00 |
| | 6 | \$1,346.39 | | \$0.00 |
| | 7 | \$1,570.78 | | \$0.00 |
| 6 CY Dumpster | 1 | \$285.05 | | \$0.00 |
| | 2 | \$570.09 | | \$0.00 |
| | 3 | \$855.14 | | \$0.00 |
| | 4 | \$1,140.18 | | \$0.00 |
| | 5 | \$1,425.23 | | \$0.00 |
| | 6 | \$1,710.27 | | \$0.00 |
| | 7 | \$1,995.32 | | \$0.00 |
| 8 CY to 40 CY Roll-offs | 1 | \$174.36 | 2 | \$4,184.64 |
| | 2 | \$348.73 | | \$0.00 |
| | 3 | \$523.09 | | \$0.00 |
| | 4 | \$697.45 | | \$0.00 |
| | 5 | \$871.82 | | \$0.00 |
| | 6 | \$1,046.18 | | \$0.00 |
| | 7 | \$1,220.54 | | \$0.00 |
| Compactor | 1 | \$180.43 | | \$0.00 |
| | 2 | \$360.86 | | \$0.00 |
| | 3 | \$541.28 | | \$0.00 |
| | 4 | \$721.71 | | \$0.00 |
| | 5 | \$902.14 | | \$0.00 |
| | 6 | \$1,082.57 | | \$0.00 |
| | 7 | \$1,262.99 | | \$0.00 |
| Total Proposed Annual Amount (3B) | | | | \$124,151.64 |

Permanent Roll-Offs and Compactors: All 8, 10, 20, 30, 40 CY Roll-offs and compactors are pull rates only; total cost will be based on actual Disposal and/or Processing costs. Rates charged to Customers should include the total cost for pull, Processing and Disposal rates.

Temporary Roll-offs (Non-permanent service of no more than 30 consecutive days at Customer's site): Shall be charged as accordingly to the Service Rates indicated above and may charge an additional daily rental fee (See Extra Services Fees).

*Estimated No. of Collections per Week is based on 2019 Customer data submitted by the current non-exclusive commercial franchise waste haulers. Each of the Service Areas have different Customer counts.

Additional Entry: *(Proposer may use this space to add additional information such as additional facilities and if Proposer would like to add any additional service levels and Container sizes that may have not been identified above)*

The undersigned Proposer offers to perform the work described in the Request for Proposals (RFP) for the following price(s). The Proposer rate(s) (hourly, monthly, etc.) shall include all administrative costs, franchise fees, labor, supervision, overtime, materials, transportation, taxes, equipment, and supplies unless stated otherwise in the RFP. The Proposer understands and agrees that the quantities set forth in the Schedule of Prices by the County are only estimates are based on current hauler submittals. Any unit prices quoted by the Proposer in this Schedule of Prices will apply to the actual quantities of work. The Proposer may use the estimates to develop its cost and rate proposal. The Proposer understands and agrees that each of the Service Areas have different Customer counts. County makes no representation or warranties of any kind, expressed or implied, as to the accuracy of the information set forth in the Schedule of Prices. County will not be liable for any damages or loss of any nature, including, but not limited to, lost profits, resulting from the estimates provided by the County. Proposer agrees to indemnify and hold the County harmless with respect to any issues, disputes, claims, lawsuits resulting from the estimates provided by the County in this solicitation, and in particular, as set forth in the Schedule of Prices. It is the responsibility of the proposer to undertake, at its sole cost, any verification of any and all information necessary for the preparation and submittal of a response to this RFP.

It is the County's sole discretion to select the collection method for each Service Area after receipt of all proposals. The County's selected collection method may not be the lowest cost collection method. The County may consider factors including but not limited to, cost per cubic yard, readiness to implement, regulatory compliance, and waste diversion potential, when deciding upon a collection method for each Service Area.

Instructions: Proposer shall enter proposed monthly rates in the blue boxes below. Proposer must submit a proposal/bid for each collection method: Three-Container, Two-Container and One-Container collection methods. Failure to do so may result in the proposal/bid being rejected as nonresponsive. All proposers should include the 14% franchise fee in their proposed rates. Proposers shall not change the numbers in Column D- Estimated No. of Collections per Week. Column E will auto calculate the Proposed Annual Amount for each service. The Proposed Total Annual Amounts for Collection Services of the County selected collection method will be used for the evaluation evaluated. Proposer is responsible for ensuring accuracy of calculations.

If Proposer does not currently offer the One-Container and Two-Container collection methods, Proposer shall input rates utilizing the facility tipping fee of a potential development of a High Diversion Organic Waste Processing Facility (HDOWPF) located in South Gate which will process Mixed Waste (Refuse and Organic Waste) at \$105 per ton,– OR – another High Diversion Organic Waste Processing Facility of Proposer's choosing with a reasonably similar tipping fee, location, and diversion rate that is in compliance with SB 1383 regulations as defined in 14 CCR Section 18982(a)(33). Proposer may also include in their proposal, an option to provide One-Container or Two-Container Collection Services for select Customers so long as the Proposer's proposal indicates how the results would provide similar diversion and cost effectiveness.

Residential Mixed Waste Processing Collection Services (Two-Container B- Gray & Green Containers)

Gray Container: Allows for the collection of intentional commingled wastes including Organic Waste (paper, cardboard) and Non-Organic Recyclables (bottles and cans), and Refuse.

Green Container: Limited to only Organic Waste sent to a source separated organics facility. This includes food waste and yard waste.

Note: The following rates apply to Residential Customers for collecting all commingled wastes & Non-Organic Recyclables in the **gray** container.

Processing Facility Name: UNIVERSAL RESOURCE RECOVERY SANTA FE SPRINGS

Processing Material(s): AS DEFINED ABOVE Rate (Per Ton) \$125.00

| Service Description | Collection Frequency (No. of Pickups per Week) | Monthly Unit Price/Rate | *Estimated No. of Collections per Week | Annual Amount (Monthly Unit Price/Rate x Estimated No. of Collections per Week x 12) |
|---------------------|--|-------------------------|--|--|
| 32-Gallon Cart | 1 | \$21.89 | | \$0.00 |
| | 2 | \$40.13 | | \$0.00 |
| | 3 | \$58.37 | | \$0.00 |
| | 4 | \$76.61 | | \$0.00 |
| | 5 | \$127.68 | | \$0.00 |
| | 6 | \$196.99 | | \$0.00 |
| | 7 | \$226.18 | | \$0.00 |
| | | | | |

| | | | | |
|-----------------|---|------------|----|--------------|
| 64-Gallon Cart | 1 | \$38.30 | | \$0.00 |
| | 2 | \$58.37 | | \$0.00 |
| | 3 | \$114.91 | | \$0.00 |
| | 4 | \$145.92 | | \$0.00 |
| | 5 | \$180.58 | | \$0.00 |
| | 6 | \$209.76 | | \$0.00 |
| | 7 | \$228.00 | | \$0.00 |
| 96-Gallon Cart | 1 | \$60.19 | | \$0.00 |
| | 2 | \$114.36 | | \$0.00 |
| | 3 | \$150.84 | | \$0.00 |
| | 4 | \$183.68 | | \$0.00 |
| | 5 | \$216.51 | | \$0.00 |
| | 6 | \$251.16 | | \$0.00 |
| | 7 | \$296.76 | | \$0.00 |
| 1 CY Dumpster | 1 | \$82.08 | 1 | \$984.96 |
| | 2 | \$164.16 | | \$0.00 |
| | 3 | \$246.24 | | \$0.00 |
| | 4 | \$328.32 | | \$0.00 |
| | 5 | \$410.40 | | \$0.00 |
| | 6 | \$492.48 | | \$0.00 |
| | 7 | \$574.56 | | \$0.00 |
| 1.5 CY Dumpster | 1 | \$87.55 | 25 | \$26,265.00 |
| | 2 | \$175.10 | | \$0.00 |
| | 3 | \$262.66 | | \$0.00 |
| | 4 | \$350.21 | | \$0.00 |
| | 5 | \$437.76 | | \$0.00 |
| | 6 | \$525.31 | | \$0.00 |
| | 7 | \$612.86 | | \$0.00 |
| 2 CY Dumpster | 1 | \$94.85 | 25 | \$28,455.00 |
| | 2 | \$189.70 | 1 | \$2,276.40 |
| | 3 | \$284.54 | | \$0.00 |
| | 4 | \$379.39 | | \$0.00 |
| | 5 | \$474.24 | | \$0.00 |
| | 6 | \$569.09 | | \$0.00 |
| | 7 | \$663.94 | | \$0.00 |
| 3 CY Dumpster | 1 | \$167.81 | 77 | \$155,056.44 |
| | 2 | \$335.62 | 15 | \$60,411.60 |
| | 3 | \$503.42 | | \$0.00 |
| | 4 | \$547.20 | | \$0.00 |
| | 5 | \$839.04 | | \$0.00 |
| | 6 | \$1,006.85 | | \$0.00 |
| | 7 | \$1,174.66 | | \$0.00 |
| 4 CY Dumpster | 1 | \$269.95 | 1 | \$3,239.40 |
| | 2 | \$539.90 | | \$0.00 |
| | 3 | \$809.86 | | \$0.00 |
| | 4 | \$1,079.81 | | \$0.00 |
| | 5 | \$1,349.76 | | \$0.00 |
| | 6 | \$1,619.71 | | \$0.00 |
| | 7 | \$1,889.66 | | \$0.00 |

| | | | | |
|---|---|------------|---|---------------------|
| 6 CY Dumpster | 1 | \$342.91 | | \$0.00 |
| | 2 | \$685.82 | | \$0.00 |
| | 3 | \$1,028.74 | | \$0.00 |
| | 4 | \$1,371.65 | | \$0.00 |
| | 5 | \$1,714.56 | | \$0.00 |
| | 6 | \$2,057.47 | | \$0.00 |
| | 7 | \$2,400.38 | | \$0.00 |
| 8 CY to 40 CY Roll-offs | 1 | \$209.76 | 2 | \$5,034.24 |
| | 2 | \$419.52 | | \$0.00 |
| | 3 | \$629.28 | | \$0.00 |
| | 4 | \$836.04 | | \$0.00 |
| | 5 | \$1,048.80 | | \$0.00 |
| | 6 | \$1,258.56 | | \$0.00 |
| | 7 | \$1,468.32 | | \$0.00 |
| Compactor | 1 | \$217.06 | | \$0.00 |
| | 2 | \$434.11 | | \$0.00 |
| | 3 | \$651.17 | | \$0.00 |
| | 4 | \$868.22 | | \$0.00 |
| | 5 | \$1,085.28 | | \$0.00 |
| | 6 | \$1,302.34 | | \$0.00 |
| | 7 | \$1,519.39 | | \$0.00 |
| Total Proposed Annual Amount (3C) | | | | \$281,723.04 |
| <p>Permanent Roll-Offs and Compactors: All 8, 10, 20, 30, 40 CY Roll-offs and compactors are pull rates only; total cost will be based on actual Disposal and/or Processing costs. Rates charged to Customers should include the total cost for pull, Processing and Disposal rates.</p> <p>Temporary Roll-offs (Non-permanent service of no more than 30 consecutive days at Customer's site): Shall be charged as accordingly to the Service Rates indicated above and may charge an additional daily rental fee (See Extra Services Fees).</p> | | | | |

*Estimated No. of Collections per Week is based on 2019 Customer data submitted by the current non-exclusive commercial franchise waste haulers. Each of the Service Areas have different Customer counts.

Additional Entry: (Proposer may use this space to add additional information such as additional facilities and if Proposer would like to add any additional service levels and Container sizes that may have not been identified above)

The undersigned Proposer offers to perform the work described in the Request for Proposals (RFP) for the following price(s). The Proposer rate(s) (hourly, monthly, etc.) shall include all administrative costs, franchise fees, labor, supervision, overtime, materials, transportation, taxes, equipment, and supplies unless stated otherwise in the RFP. The Proposer understands and agrees that the quantities set forth in the Schedule of Prices by the County are only estimates are based on current hauler submittals. Any unit prices quoted by the Proposer in this Schedule of Prices will apply to the actual quantities of work. The Proposer may use the estimates to develop its cost and rate proposal. The Proposer understands and agrees that each of the Service Areas have different Customer counts. County makes no representation or warranties of any kind, expressed or implied, as to the accuracy of the information set forth in the Schedule of Prices. County will not be liable for any damages or loss of any nature, including, but not limited to, lost profits, resulting from the estimates provided by the County. Proposer agrees to indemnify and hold the County harmless with respect to any issues, disputes, claims, lawsuits resulting from the estimates provided by the County in this solicitation, and in particular, as set forth in the Schedule of Prices. It is the responsibility of the proposer to undertake, at its sole cost, any verification of any and all information necessary for the preparation and submittal of a response to this RFP.

It is the County's sole discretion to select the collection method for each Service Area after receipt of all proposals. The County's selected collection method may not be the lowest cost collection method. The County may consider factors including but not limited to, cost per cubic yard, readiness to implement, regulatory compliance, and waste diversion potential, when deciding upon a collection method for each Service Area.

Instructions: Proposer shall enter proposed monthly rates in the blue boxes below. Proposer must submit a proposal/bid for each collection method: Three-Container, Two-Container and One-Container collection methods. Failure to do so may result in the proposal/bid being rejected as nonresponsive. All proposers should include the 14% franchise fee in their proposed rates. Proposers shall not change the numbers in Column D- Estimated No. of Collections per Week. Column E will auto calculate the Proposed Annual Amount for each service. The Proposed Total Annual Amounts for Collection Services of the County selected collection method will be used for the evaluation evaluated. Proposer is responsible for ensuring accuracy of calculations.

If Proposer does not currently offer the One-Container and Two-Container collection methods, Proposer shall input rates utilizing the facility tipping fee of a potential development of a High Diversion Organic Waste Processing Facility (HDOWPF) located in South Gate which will process Mixed Waste (Refuse and Organic Waste) at \$105 per ton, – OR – another High Diversion Organic Waste Processing Facility of Proposer's choosing with a reasonably similar tipping fee, location, and diversion rate that is in compliance with SB 1383 regulations as defined in 14 CCR Section 18982(a)(33). Proposer may also include in their proposal, an option to provide One-Container or Two-Container Collection Services for select Customers so long as the Proposer's proposal indicates how the results would provide similar diversion and cost effectiveness.

Residential Mixed Waste Processing Collection Services (Two-Container B- Gray & Green Containers)

Gray Container: Allows for the collection of intentional commingled wastes including Organic Waste (paper, cardboard) and Non-Organic Recyclables (bottles and cans), and Refuse.

Green Container: Limited to only Organic Waste sent to a source separated organics facility. This includes food waste and yard waste.

Note: The following rates apply to Residential Customers for collecting Organic Waste in the **green container**.

Processing Facility Name: UNIVERSAL RESOURCE RECOVERY SANTA FE SPRINGS

Processing Material(s): AS DEFINED ABOVE Rate (Per Ton) \$125.00

| Service Description | Collection Frequency (No. of Pickups per Week) | Monthly Unit Price/Rate | *Estimated No. of Collections per Week | Annual Amount (Monthly Unit Price/Rate x Estimated No. of Collections per Week x 12) |
|---------------------|--|-------------------------|--|--|
| 32-Gallon Cart | 1 | \$21.89 | | \$0.00 |
| | 2 | \$40.13 | | \$0.00 |
| | 3 | \$58.37 | | \$0.00 |
| | 4 | \$76.61 | | \$0.00 |
| | 5 | \$127.68 | | \$0.00 |
| | 6 | \$196.99 | | \$0.00 |
| | 7 | \$226.18 | | \$0.00 |
| | | | | |

| | | | | |
|------------------------|---|------------|----|-------------|
| 64-Gallon Cart | 1 | \$38.30 | 26 | \$11,949.60 |
| | 2 | \$58.37 | | \$0.00 |
| | 3 | \$114.91 | | \$0.00 |
| | 4 | \$145.92 | | \$0.00 |
| | 5 | \$180.58 | | \$0.00 |
| | 6 | \$209.76 | | \$0.00 |
| | 7 | \$228.00 | | \$0.00 |
| 96-Gallon Cart | | | | |
| 96-Gallon Cart | 1 | \$60.19 | 25 | \$18,057.00 |
| | 2 | \$114.36 | 1 | \$1,372.32 |
| | 3 | \$150.84 | | \$0.00 |
| | 4 | \$183.68 | | \$0.00 |
| | 5 | \$216.51 | | \$0.00 |
| | 6 | \$251.16 | | \$0.00 |
| | 7 | \$296.76 | | \$0.00 |
| 1 CY Dumpster | | | | |
| 1 CY Dumpster | 1 | \$82.08 | 78 | \$76,826.88 |
| | 2 | \$164.16 | 15 | \$29,548.80 |
| | 3 | \$246.24 | | \$0.00 |
| | 4 | \$328.32 | | \$0.00 |
| | 5 | \$410.40 | | \$0.00 |
| | 6 | \$492.48 | | \$0.00 |
| | 7 | \$574.56 | | \$0.00 |
| 1.5 CY Dumpster | | | | |
| 1.5 CY Dumpster | 1 | \$87.55 | | \$0.00 |
| | 2 | \$175.10 | | \$0.00 |
| | 3 | \$262.66 | | \$0.00 |
| | 4 | \$350.21 | | \$0.00 |
| | 5 | \$437.76 | | \$0.00 |
| | 6 | \$525.31 | | \$0.00 |
| | 7 | \$612.86 | | \$0.00 |
| 2 CY Dumpster | | | | |
| 2 CY Dumpster | 1 | \$94.85 | | \$0.00 |
| | 2 | \$189.70 | | \$0.00 |
| | 3 | \$284.54 | | \$0.00 |
| | 4 | \$379.39 | | \$0.00 |
| | 5 | \$474.24 | | \$0.00 |
| | 6 | \$569.09 | | \$0.00 |
| | 7 | \$663.94 | | \$0.00 |
| 3 CY Dumpster | | | | |
| 3 CY Dumpster | 1 | \$167.81 | | \$0.00 |
| | 2 | \$335.62 | | \$0.00 |
| | 3 | \$503.42 | | \$0.00 |
| | 4 | \$547.20 | | \$0.00 |
| | 5 | \$839.04 | | \$0.00 |
| | 6 | \$1,006.85 | | \$0.00 |
| | 7 | \$1,174.66 | | \$0.00 |
| 4 CY Dumpster | | | | |
| 4 CY Dumpster | 1 | \$269.95 | | \$0.00 |
| | 2 | \$539.90 | | \$0.00 |
| | 3 | \$809.86 | | \$0.00 |
| | 4 | \$1,079.81 | | \$0.00 |
| | 5 | \$1,349.76 | | \$0.00 |
| | 6 | \$1,619.71 | | \$0.00 |
| | 7 | \$1,889.66 | | \$0.00 |

| | | | | |
|---|---|------------|---|---------------------|
| 6 CY Dumpster | 1 | \$342.91 | | \$0.00 |
| | 2 | \$685.82 | | \$0.00 |
| | 3 | \$1,028.74 | | \$0.00 |
| | 4 | \$1,371.65 | | \$0.00 |
| | 5 | \$1,714.56 | | \$0.00 |
| | 6 | \$2,057.47 | | \$0.00 |
| | 7 | \$2,400.38 | | \$0.00 |
| 8 CY to 40 CY Roll-offs | | | | |
| | 1 | \$209.76 | 2 | \$5,034.24 |
| | 2 | \$419.52 | | \$0.00 |
| | 3 | \$629.28 | | \$0.00 |
| | 4 | \$836.04 | | \$0.00 |
| | 5 | \$1,048.80 | | \$0.00 |
| | 6 | \$1,258.56 | | \$0.00 |
| | 7 | \$1,468.32 | | \$0.00 |
| Compactor | | | | |
| | 1 | \$217.06 | | \$0.00 |
| | 2 | \$434.11 | | \$0.00 |
| | 3 | \$651.17 | | \$0.00 |
| | 4 | \$868.22 | | \$0.00 |
| | 5 | \$1,085.28 | | \$0.00 |
| | 6 | \$1,302.34 | | \$0.00 |
| | 7 | \$1,519.39 | | \$0.00 |
| Total Proposed Annual Amount (3D) | | | | \$142,788.84 |
| <p>Permanent Roll-Offs and Compactors: All 8, 10, 20, 30, 40 CY Roll-offs and compactors are pull rates only; total cost will be based on actual Disposal and/or Processing costs. Rates charged to Customers should include the total cost for pull, Processing and Disposal rates.</p> <p>Temporary Roll-offs (Non-permanent service of no more than 30 consecutive days at Customer's site): Shall be charged as accordingly to the Service Rates indicated above and may charge an additional daily rental fee (See Extra Services Fees).</p> | | | | |

*Estimated No. of Collections per Week is based on 2019 Customer data submitted by the current non-exclusive commercial franchise waste haulers. Each of the Service Areas have different Customer counts.

Additional Entry: (Proposer may use this space to add additional information such as additional facilities and if Proposer would like to add any additional service levels and Container sizes that may have not been identified above)

The undersigned Proposer offers to perform the work described in the Request for Proposals (RFP) for the following price(s). The Proposer rate(s) (hourly, monthly, etc.) shall include all administrative costs, franchise fees, labor, supervision, overtime, materials, transportation, taxes, equipment, and supplies unless stated otherwise in the RFP. The Proposer understands and agrees that the quantities set forth in the Schedule of Prices by the County are only estimates based on current hauler submittals. Any unit prices quoted by the Proposer in this Schedule of Prices will apply to the actual quantities of work. The Proposer may use the estimates to develop its cost and rate proposal. The Proposer understands and agrees that each of the Service Areas have different Customer counts. County makes no representation or warranties of any kind, expressed or implied, as to the accuracy of the information set forth in the Schedule of Prices. County will not be liable for any damages or loss of any nature, including, but not limited to, lost profits, resulting from the estimates provided by the County. Proposer agrees to indemnify and hold the County harmless with respect to any issues, disputes, claims, lawsuits resulting from the estimates provided by the County in this solicitation, and in particular, as set forth in the Schedule of Prices. It is the responsibility of the proposer to undertake, at its sole cost, any verification of any and all information necessary for the preparation and submittal of a response to this RFP.

It is the County's sole discretion to select the collection method for each Service Area after receipt of all proposals. The County's selected collection method may not be the lowest cost collection method. The County may consider factors including but not limited to, cost per cubic yard, readiness to implement, regulatory compliance, and waste diversion potential, when deciding upon a collection method for each Service Area.

Instructions: Proposer shall enter proposed monthly rates in the blue boxes below. Proposer must submit a proposal/bid for each collection method: Three-Container, Two-Container and One-Container collection methods. Failure to do so may result in the proposal/bid being rejected as nonresponsive. All proposers should include the 14% franchise fee in their proposed rates. Proposers shall not change the numbers in Column D- Estimated No. of Collections per Week. Column E will auto calculate the Proposed Annual Amount for each service. The Proposed Total Annual Amounts for Collection Services of the County selected collection method will be used for the evaluation evaluated. Proposer is responsible for ensuring accuracy of calculations.

If Proposer does not currently offer the One-Container and Two-Container collection methods, Proposer shall input rates utilizing the facility tipping fee of a potential development of a High Diversion Organic Waste Processing Facility (HDOWPF) located in South Gate which will process Mixed Waste (Refuse and Organic Waste) at \$105 per ton, – OR – another High Diversion Organic Waste Processing Facility of Proposer's choosing with a reasonably similar tipping fee, location, and diversion rate that is in compliance with SB 1383 regulations as defined in 14 CCR Section 18982(a)(33). Proposer may also include in their proposal, an option to provide One-Container or Two-Container Collection Services for select Customers so long as the Proposer's proposal indicates how the results would provide similar diversion and cost effectiveness.

Residential Mixed Waste Processing Collection Services (One-Container)

Note: The following rates apply to Residential Customers for collecting Refuse, Recycling and Organic Waste materials into a single gray container.

Processing Facility Name: UNIVERSAL RESOURCE RECOVERY SANTA FE SPRINGS

Processing Material(s): AS DEFINED ABOVE Rate (Per Ton) \$125.00

| Service Description | Collection Frequency (No. of Pickups per Week) | Monthly Unit Price/Rate | *Estimated No. of Collections per Week | Annual Amount (Monthly Unit Price/Rate x Estimated No. of Collections per Week x 12) |
|---------------------|--|-------------------------|--|--|
| 32-Gallon Cart | 1 | \$20.52 | | \$0.00 |
| | 2 | \$37.62 | | \$0.00 |
| | 3 | \$54.72 | | \$0.00 |
| | 4 | \$71.82 | | \$0.00 |
| | 5 | \$119.70 | | \$0.00 |
| | 6 | \$184.68 | | \$0.00 |
| | 7 | \$212.04 | | \$0.00 |
| 64-Gallon Cart | 1 | \$35.91 | | \$0.00 |
| | 2 | \$54.72 | | \$0.00 |
| | 3 | \$107.73 | | \$0.00 |
| | 4 | \$136.80 | | \$0.00 |
| | 5 | \$169.29 | | \$0.00 |
| | 6 | \$196.65 | | \$0.00 |
| | 7 | \$213.75 | | \$0.00 |
| 96-Gallon Cart | 1 | \$56.43 | | \$0.00 |
| | 2 | \$107.22 | | \$0.00 |
| | 3 | \$141.42 | | \$0.00 |
| | 4 | \$172.20 | | \$0.00 |
| | 5 | \$202.98 | | \$0.00 |
| | 6 | \$235.47 | | \$0.00 |
| | 7 | \$278.22 | | \$0.00 |
| 1 CY Dumpster | 1 | \$76.95 | 1 | \$923.40 |
| | 2 | \$153.90 | | \$0.00 |
| | 3 | \$230.85 | | \$0.00 |
| | 4 | \$307.80 | | \$0.00 |
| | 5 | \$384.75 | | \$0.00 |
| | 6 | \$461.70 | | \$0.00 |
| | 7 | \$538.68 | | \$0.00 |
| 1.5 CY Dumpster | 1 | \$82.08 | 25 | \$24,624.00 |
| | 2 | \$164.16 | | \$0.00 |
| | 3 | \$246.24 | | \$0.00 |
| | 4 | \$328.32 | | \$0.00 |
| | 5 | \$410.40 | | \$0.00 |
| | 6 | \$492.48 | | \$0.00 |
| | 7 | \$574.56 | | \$0.00 |
| 2 CY Dumpster | 1 | \$88.92 | 25 | \$26,676.00 |
| | 2 | \$177.84 | 1 | \$2,134.08 |
| | 3 | \$266.76 | | \$0.00 |
| | 4 | \$355.68 | | \$0.00 |
| | 5 | \$444.60 | | \$0.00 |
| | 6 | \$533.52 | | \$0.00 |
| | 7 | \$622.44 | | \$0.00 |

| | | | | |
|--|---|------------|----|---------------------|
| 3 CY Dumpster | 1 | \$157.32 | 77 | \$145,363.68 |
| | 2 | \$314.64 | 15 | \$56,635.20 |
| | 3 | \$471.96 | | \$0.00 |
| | 4 | \$513.00 | | \$0.00 |
| | 5 | \$786.60 | | \$0.00 |
| | 6 | \$943.92 | | \$0.00 |
| | 7 | \$1,101.24 | | \$0.00 |
| 4 CY Dumpster | 1 | \$253.08 | 1 | \$3,036.96 |
| | 2 | \$506.16 | | \$0.00 |
| | 3 | \$759.24 | | \$0.00 |
| | 4 | \$1,012.32 | | \$0.00 |
| | 5 | \$1,265.40 | | \$0.00 |
| | 6 | \$1,518.48 | | \$0.00 |
| | 7 | \$1,771.56 | | \$0.00 |
| 6 CY Dumpster | 1 | \$321.48 | | \$0.00 |
| | 2 | \$642.96 | | \$0.00 |
| | 3 | \$964.44 | | \$0.00 |
| | 4 | \$1,285.92 | | \$0.00 |
| | 5 | \$1,607.40 | | \$0.00 |
| | 6 | \$1,928.88 | | \$0.00 |
| | 7 | \$2,250.36 | | \$0.00 |
| 8 CY to 40 CY Roll-offs | 1 | \$196.65 | 2 | \$4,719.60 |
| | 2 | \$393.30 | | \$0.00 |
| | 3 | \$589.95 | | \$0.00 |
| | 4 | \$786.60 | | \$0.00 |
| | 5 | \$983.25 | | \$0.00 |
| | 6 | \$1,179.90 | | \$0.00 |
| | 7 | \$1,376.55 | | \$0.00 |
| Compactor | 1 | \$203.49 | | \$0.00 |
| | 2 | \$406.98 | | \$0.00 |
| | 3 | \$610.47 | | \$0.00 |
| | 4 | \$813.96 | | \$0.00 |
| | 5 | \$1,017.45 | | \$0.00 |
| | 6 | \$1,220.94 | | \$0.00 |
| | 7 | \$1,424.43 | | \$0.00 |
| Total Proposed Annual Amount (3E) | | | | \$264,112.92 |

Permanent Roll-Offs and Compactors: All 8, 10, 20, 30, 40 CY Roll-offs and compactors are pull rates only; total cost will be based on actual Disposal and/or Processing costs. Rates charged to Customers should include the total cost for pull, Processing and Disposal rates.

Temporary Roll-offs (Non-permanent service of no more than 30 consecutive days at Customer's site): Shall be charged as accordingly to the Service Rates indicated above and may charge an additional daily rental fee (See Extra Services Fees).

*Estimated No. of Collections per Week is based on 2019 Customer data submitted by the current non-exclusive commercial franchise waste haulers. Each of the Service Areas have different Customer counts.

Additional Entry: (Proposer may use this space to add additional information such as additional facilities and if Proposer would like to add any additional service levels and Container sizes that may have not been identified above)

Rates Summary

Note: The Total Proposed Annual Amounts from all the proposal rate sheets for Mixed Waste Processing Collection Services rates will be automatically calculated into the table below. Proposer is responsible for ensuring accuracy of calculations. Proposer must fill and sign the signature block acknowledgement below upon confirming calculations.

| Title | Proposed Total Annual Amounts |
|---|-------------------------------|
| Commercial Mixed Waste Processing Collection Services Rates Two-Container A: Gray and Blue Containers (1A+1B) | \$2,132,967.60 |
| Multifamily Mixed Waste Processing Collection Services Rates Two-Container A: Gray and Blue Containers (2A+2B) | \$1,830,923.16 |
| Residential Mixed Waste Processing Collection Services Rates Two-Container A: Gray and Blue Containers (3A+3B) | \$124,151.64 |
| Total Proposed Annual Amount for Two-Container A: Gray and Blue Containers (Total Proposed Annual Amounts of 1A+1B+2A+2B+3A+3B) | \$4,088,042.40 |
| Commercial Mixed Waste Processing Collection Services Rates Two-Container B: Gray and Green Containers (1C+1D) | \$2,535,181.80 |
| Multifamily Mixed Waste Processing Collection Services Rates Two-Container B: Gray and Green Containers (2C+2D) | \$2,151,281.88 |
| Residential Mixed Waste Processing Collection Services Rates Two-Container B: Gray and Green Containers (3C+3D) | \$424,511.88 |
| Total Proposed Annual Amount for Two-Container B: Gray and Green Containers (Total Proposed Annual Amounts of 1C+1D+2C+2D+3C+3D) | \$5,110,975.56 |
| Commercial Mixed Waste Processing Collection Services Rates One-Container: Gray Container (Refuse, Recycling and Organic Waste) (1E) | \$1,570,826.52 |
| Multifamily Mixed Waste Processing Collection Services Rates One-Container: Gray Container (Refuse, Recycling and Organic Waste) (2E) | \$264,112.92 |
| Residential Mixed Waste Processing Collection Services Rates One-Container: Gray Container (Refuse, Recycling and Organic Waste) (3E) | \$264,112.92 |
| Total Proposed Annual Amount for One-Container: Gray Container (Refuse, Recycling and Organic Waste) (Total Proposed Annual Amounts of 1E+2E+3E) | \$2,099,052.36 |

Signature Block Acknowledgement:

| | |
|--|---|
| Legal Name of Proposer WARE DISPOSAL INC. | |
| Signature of Person Authorized to Submit Proposal JAY WARE | |
| Title of Authorized Person GENERAL MANAGER | |
| Date 2 FEBRUARY 2022 | State Contractor's License Number CA55393 |
| Proposer's Address:1035 EAST 4TH STREET SANTA ANA, CALIFORNIA 92701 4750 | |
| E-Mail jay@waredisposal.com/jason@waredisposal.com | |
| Phone 877 714 9273 | Mobile 714 906 2887 |

EXHIBIT 12-D2 – Liquidated Damages

Reference to "failure" refers to each occurrence of specified Breach (such as for each Occupant and each Occupant's Collection site, Record entry, or complaint) and not for aggregate occurrences of those Breaches (such as for all Customers and Occupants on a given route or day). Per day means each business day except as indicated.

If CONTRACTOR does not timely submit the applicable information, documentation or complete Report or incorporate comments, additions and corrections made by Director within five days of receipt of those comments, additions, and corrections, it shall pay the following liquidated damages.

| No. | Section | Failure | Damage |
|-----|-------------------------|--|-----------------------------------|
| 1 | Item D of Exhibit 3A1 | Use of Solid Waste Facility(s) that are not Approved by the COUNTY | \$100 per ton |
| 2 | Item A1 of Exhibit 3A1 | Failure to provide Collection Services and deliver appropriate Collection Containers for the Collection of Solid Waste (Refuse, Recyclables and Organic Waste) to each and every Customer within the CONTRACTOR's Service Area after Contract Execution Date (exception for customers who are exempt from Service) | \$200 per Customer per week |
| 3 | Item E 5 of Exhibit 3A1 | Failure to Process Recyclables, or mixing Recyclables and/or Organic Waste with Refuse (exception for mixed waste collection which shall be sent to an approved HDOWPF) | \$1000 per Vehicle per occurrence |
| 4 | Item I of Section 4 | Commingling materials from outside the Service Area with Solid Waste that CONTRACTOR Collects inside the Service Area, such as commingling Collected Solid Waste from Garbage Disposal Districts (GDD), incorporated cities or other counties with Solid Waste Collected from their Service Area. | \$500 per Vehicle per occurrence |

| | | | |
|----|--|---|--|
| 5 | Item J1 of Exhibit 3A1 | Failure to Perform Contamination Monitoring Requirements | \$500 per hauler route for initial failure to conduct Contamination Monitoring plus \$100 per hauler route per day until contamination inspections are completed |
| 6 | Item C of Exhibit 3A1 | Failure to Comply with Container Labeling and Colors requirements | \$100 per occurrence per Container |
| 7 | Item J2 of Exhibit 3A1 & Item D1e of Section 6 | Failure to assist the COUNTY with SB 1383 related compliance tasks such as waivers, non-compliance complaints, and any other SB 1383 related requests not captured in any other category in this Exhibit 12-D2. | \$100 per occurrence |
| 8 | Section 13 | Failure to follow Unpermitted Waste Screening Protocol and Reporting | \$500 per occurrence |
| 9 | Item 2 of Section 10 | Failure to provide Route maps and schedules | \$100 per day |
| 10 | Item I of Exhibit 3A1 | Failure to conduct site visits and waste assessments | \$300 per occurrence |
| 11 | Item A4 of Exhibit 3A1 | Failure to Collect during authorized hours | \$250 per occurrence |
| 12 | Section 4 | Failure to meet Service Standards for litter, spills, leaks and noise | \$150 per day |
| 13 | Item H of Section 4 | Each failure during any calendar month to return Director calls, emails or to timely meet with COUNTY in accordance with Section 4H. | \$500 per occurrence |
| 14 | Item C5 of Exhibit 3A1 | Failure to timely remove graffiti accordance with item C5 of Exhibit 3A1 | \$100 per day |
| 15 | Item C8 of Exhibit 3A1 | Failure to timely repair or replace Container(s) (upon Customer request) | \$500 per occurrence |

| | | | |
|----|------------------------|---|---|
| 16 | Section 10 | Failure to submit complete and correct information or Reports on time: (1) quarterly, (2) annually, (3) as required by any State Laws or County Code, or (4) any other time required under this CONTRACT. | Until corrected or completed: (1) \$200 per day (2) \$300 per day (3) \$150 per day (4) \$100 per day |
| 17 | Section 9 | Failure to allow COUNTY to inspect, audit or copy Records | \$150 per requested record per occurrence |
| 18 | Item F of Section 4 | Failure to provide documentation for COUNTY review or comment; or to obtain any COUNTY approval, consent or other permission | \$300 per day per occurrence or retraction/correction of misinformation |
| 19 | Item I of Exhibit 3A1 | Failure to Perform Public Education and Outreach | \$100 per occurrence |
| 20 | Item I of Exhibit 3A1 | Failure to timely provide Customer with Bill of Rights and/or Subscription Order Form | \$100 per day per customer per occurrence |
| 21 | Item B1 of Section 7 | Itemizing the Franchise Fee on a Customer's invoice | \$100 per Customer per invoice |
| 22 | Item A5 of Exhibit 3A1 | Failure to tag non-collected Solid Waste and keep a record of reason | \$150 per occurrence per day |
| 23 | Item D of Section 6 | Failure to honor commitment to resolve a Customer's or Occupant's first complaint | \$100 per occurrence per day until resolution |
| 24 | Item D of Section 6 | For each failure to honor commitment to resolve Customer's or Occupant's same complaint, which generated a second complaint | \$250 per occurrence per day until resolution |
| 25 | Item D of Section 6 | For each failure to honor commitment to resolve Customer's or Occupant's same complaint, which generated a third or more complaint | \$500 for each subsequent complaint |
| 26 | Part 5C of Exhibit 5 | Failure to repair damage caused to private property | \$150 per day until resolved |

| | | | |
|----|-------------------------|--|--|
| 27 | Item A4e of Exhibit 3A1 | Missed Collection | \$100 per occurrence for each Container \$200 for each day thereafter |
| 28 | Section 1A | Collecting, removing, or transporting Solid Waste from Customers that are not within in CONTRACTOR's Service Area. | \$500 per verified occurrence |
| 29 | Section 3C | For each failure to maintain any Vehicle in accordance with Applicable Law | \$150 per Vehicle per day |
| 30 | Item C12 of Section 3 | Failure to maintain and operate GPS equipment in working order | \$100 per Vehicle per day |

By placing initials below at the places provided, each Party specifically confirms the accuracy of the statements made above and the fact that each Party has had many opportunities to consult with legal counsel and obtain an explanation of liquidated damage provisions of the time that this CONTRACT was made.

CONTRACTOR
Initial Here: *JAN*

COUNTY
Initial Here: CS

Intentionally left blank

EXHIBIT 16 – Contract Service Area Information

- A. Maps
- B. Service Areas Data Information
- C. Outreach

16.A.1- Map of Exclusive Commercial Franchise Service Areas



EXCLUSIVE COMMERCIAL FRANCHISE AGREEMENT SERVICE AREA

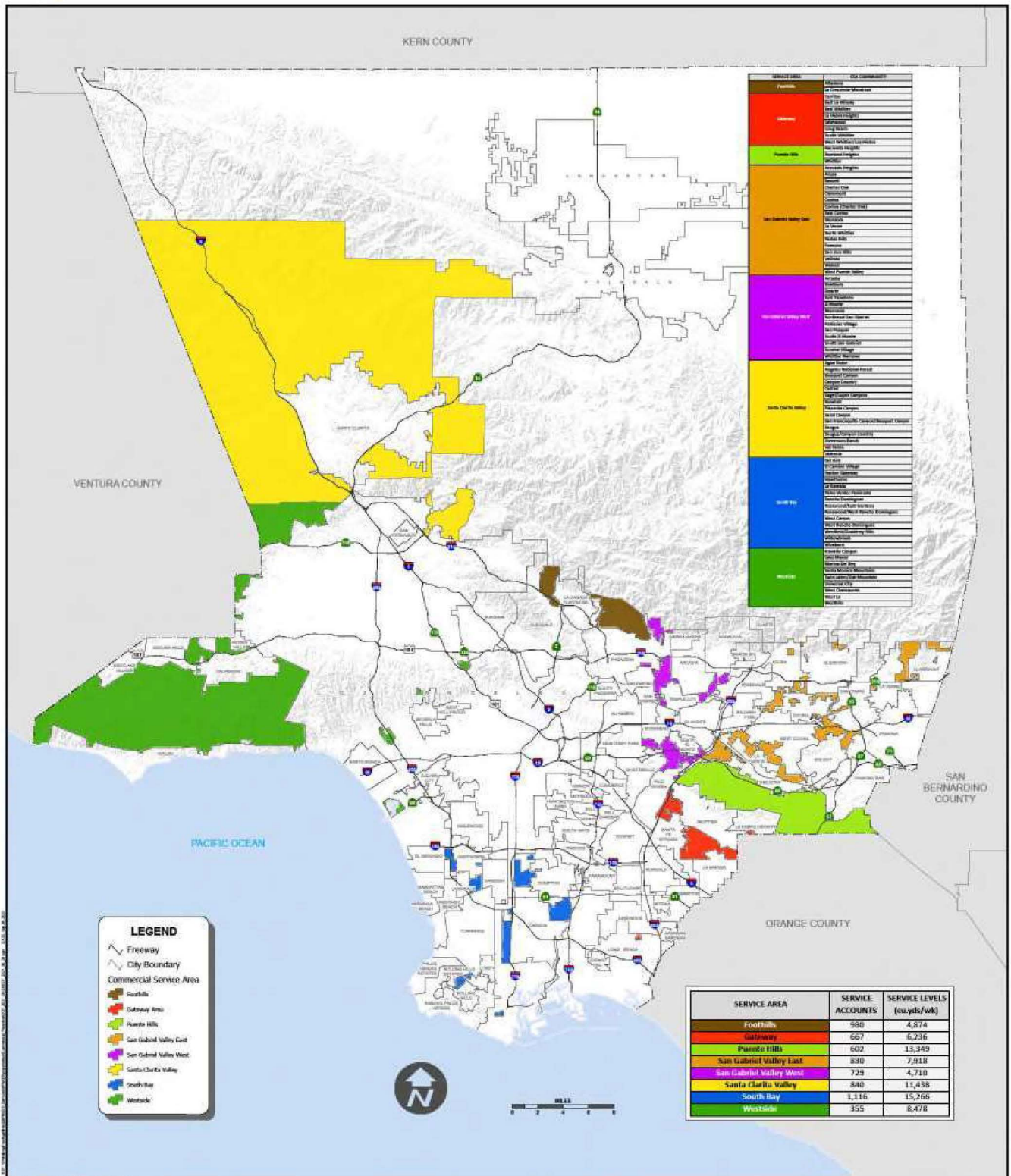

Service Areas Description:

The distribution of the zones balances the geography – in a rather contained capacity, as evident by the color grouping – with the total service accounts and service levels, emphasizing the latter.

The average size (and services) of the territories, which resulted in eight (8) zones, was based on Customer data, as determined to be appropriate capacity for waste haulers, though this is done with a greater emphasis on larger waste volumes to enable investment in Processing infrastructure.

This resulted in a natural variation among the Service Areas by size and services, which allows for different waste haulers to apply for a Service Area(s) based on their own operational capacities. Some Service Areas are intended to remain smaller to ensure viability for small waste haulers.

Foothills and San Gabriel Valley West Service Areas are the two (2) designated smaller Service Areas that have substantially lower total weekly service levels than the other six (6) Service Areas.

16.B.1- Exclusive Commercial Franchise Service Areas Data

The data provided by the existing Non-Exclusive Commercial Franchise (NECF) solid waste haulers was extracted to fit within each Service Area.

This data enabled COUNTY to compile a recent history of the Solid Waste Tonnage, and number of accounts and service levels from 2019 in the Communities that compose the new Exclusive Service Areas:

Historical Solid Waste (Tonnage)

| Service Area | 2020 | 2019 | 2018 |
|-------------------------|--------|--------|--------|
| Foothills | 7,309 | 8,986 | 9,253 |
| Gateway | 15,180 | 12,907 | 12,712 |
| Puente Hills | 34,952 | 36,863 | 35,877 |
| San Gabriel Valley East | 21,129 | 20,703 | 17,835 |
| San Gabriel Valley West | 17,557 | 21,236 | 19,511 |
| Santa Clarita Valley | 26,686 | 31,900 | 27,933 |
| South Bay | 51,687 | 42,293 | 40,339 |
| Westside | 27,273 | 27,475 | 29,926 |

Estimated 2019 Account Distribution

| Service Area | Number of Accounts | Commercial | Multifamily | Residential |
|-------------------------|--------------------|------------|-------------|-------------|
| Foothills | 1,075 | 40% | 37% | 23% |
| Gateway | 592 | 57% | 35% | 8% |
| Puente Hills | 698 | 76% | 19% | 5% |
| San Gabriel Valley East | 949 | 69% | 7% | 24% |
| San Gabriel Valley West | 758 | 49% | 32% | 19% |
| Santa Clarita Valley | 971 | 59% | 5% | 36% |
| South Bay | 956 | 86% | 12% | 2% |
| Westside | 452 | 84% | 4% | 12% |

Estimated 2019 Service Level Distribution

| Service Area | Organic Waste | Refuse Only | Refuse & Recycling | Recycling Only |
|-------------------------|---------------|-------------|--------------------|----------------|
| Foothills | 0% | 96% | 4% | 0% |
| Gateway | 0% | 74% | 26% | 0% |
| Puente Hills | 1% | 74% | 25% | 0% |
| San Gabriel Valley East | 1% | 74% | 25% | 0% |
| San Gabriel Valley West | 1% | 76% | 23% | 0% |
| Santa Clarita Valley | 0% | 73% | 25% | 2% |
| South Bay | 0% | 84% | 15% | 1% |
| Westside | 1% | 73% | 26% | 0% |

Projected 2022 Service Levels

COUNTY contracted for an independent analysis of all 2019 accounts located in the eight (8) identified Service Areas to project new service levels for all accounts to have a Three-Container system of Refuse, Recycling and Organic waste. The accounts were further organized into three (3) sectors: Commercial, Multifamily and Residential. The projected service levels for each Service Area per account type and per waste stream are indicated in Forms PW-2 and PW-3 Schedule of Prices.

The following assumptions were made for the Three-Container service level projection analysis:

- 1) There were 413 accounts, of which approximately 6% were identified as questionable (i.e., for Commercial, Multifamily and Residential sectors), not included in the analysis;
- 2) Dumpsters that are greater than or equal to eight (8) cubic yards (CY) were grouped into a Container size category of "8 CY to 40 CY";
 - a. For the purpose of estimating the volume of material for this category, an average Dumpster size of 35 CY was used;
- 3) It was also noted that some of the accounts were listed to have zero (0) Collection frequency. The accounts with zero (0) frequency were included in the analysis as 1 time per week frequency;
- 4) Green Waste is managed by third party landscapers unless a Customer has existing Green Waste service;
- 5) The average Organic Waste percentage of total Refuse (CalRecycle, 2019) for each account type was estimated as follows:

- a. Commercial – 20% (except as noted below)
 - i. This is based on the average Organic Waste composition of 20+ industries;
 - ii. For accounts that are part of the Accommodation sector, the Organic Waste composition used was 32%;
 - iii. For accounts that are part of the Restaurant sector, the Organic Waste composition used was 51%;
 - iv. For accounts that are part of the Grocer sector, the Organic Waste composition used was 42%; and,
 - v. For accounts that are part of the Arts and Entertainment (includes amusement parks and event venues) sector, the Organic Waste composition used was 34%.
 - b. Multifamily – 25%
 - c. Residential – 18%
- 6) Less than 1% of the accounts had existing Organic Waste Collection in the 2019 dataset. The projected Organic Waste volume was estimated based on the size of the Refuse Containers, estimated Refuse density for the respective sector and the Organic Waste composition assumption above for all accounts.
- 7) The average recycling percentage of total Refuse (CalRecycle, 2019) for each sector is estimated as follows:
- a. Commercial – 46%
 - i. This is based on the average Recycling composition of 20+ industries.
 - b. Multifamily – 42%
 - c. Residential – 22%
- 8) Approximately 25% of accounts had existing Recycling Collection Services. The remaining projected Recycling volume was estimated based on the volume of the Refuse Containers for the accounts that do not have Recycling Collection;
- 9) For the purposes of the new projected service levels, the Organic Waste and Recycling volume is conservatively based on 100% capture rate;
- 10) The average Refuse percentage for each sector is estimated as followed:
- a. Commercial – 58%
 - i. Assumed a 100% capture of Organic Waste and 50% capture of Recycling; and,

- ii. For accounts that have high Organic Waste composition, it is assumed to have 75% capture of Organic Waste and 50% capture of Recycling.
 - 1. For accounts that are part of the Accommodation sector, the Refuse composition used was 55%;
 - 2. For accounts that are part of the Restaurant sector, the Refuse composition used was 40%;
 - 3. For accounts that are part of the Grocer sector, the Refuse composition used was 47%; and,
 - 4. For accounts that are part of the Arts and Entertainment (includes amusement parks and event venues) sector, the Refuse composition used was 55%.
- b. Multifamily – 54%
 - i. Assumed a 100% capture of Organic Waste and 50% capture of Recycling.
- c. Residential – 80%
 - i. Assumed a 50% capture of Organic Waste and 50% capture of Recycling.

The following assumptions were made for the Two-Container service level projections analysis, applicable to all Customer types:

1) Two-Container A (Gray and Blue Containers)

- i. Gray Container (Refuse and Organic Waste) - Utilized existing Non-Exclusive Commercial Franchise Customer Refuse service level data.
- ii. Blue Container (Recyclables)- Utilized Recycling projected service levels from the three-container service level projections analysis.

2) Two-Container B (Gray and Green Containers)

- i. Gray Container (Refuse and Recyclables) - Utilized existing Non-Exclusive Commercial Franchise Customer Refuse service level data.
- ii. Green Container (Organic Waste) - Utilized Organic Waste projected service levels from the three-container service level projections analysis.

The following assumptions were made for the One-Container service level projections analysis, applicable to all Customer types:

- 1) One-Container (Gray Container)
 - i. Utilized existing Non-Exclusive Commercial Franchise Customer Refuse service level data.

16.C.1- Public Education and Outreach Guidelines

This CONTRACT includes several outreach and education materials to be created by the CONTRACTOR and/or the COUNTY and disseminated in a timely manner to support waste Diversion goals and compliance with several mandates. Below is a check list summarizing most but not all of the CONTRACTOR'S obligation of education and outreach material.

A. Outreach material to be created by the COUNTY, with input from the CONTRACTOR, and disseminated by the CONTRACTOR:

1. Terms and Conditions
 - a. Subscription Order Form
 - b. Bill of Rights
2. Letter from the Director (to be included in Welcome Packet)
3. Monthly outreach (or less frequent, at County's discretion)
4. Community meeting presentations

B. Outreach material to be created by CONTRACTOR, approved by the COUNTY, and disseminated by the CONTRACTOR:

1. Site Visit and Waste Assessment
 - a. CONTRACTOR shall make recommendations when applicable for rightsizing and reducing Container sizes. CONTRACTOR may create in a form of survey, letter, or checklist (whichever seems appropriate) and may include:
 - i. Pictures of all Containers' contents
 - ii. Establishment information and characteristics
 - iii. Written recommendations for optimal service level
 - iv. Applicable and appropriate outreach material
 - v. On-site training for Commercial Customer's employees/staff that handle any Solid Waste and determine if any on-going training is necessary
 - vi. Determine placement of signage
 - vii. Determine needs for access
 - viii. Document the need for special services, such as a seasonal automated on-call compactor
2. Welcome Packet which may include:
 - a. Letter from the Director (Bilingual)
 - b. Letter from Contractor (Bilingual)
 - i. CONTRACTOR introduction
 - ii. Transition plan
 - iii. Community meeting dates
 - iv. Any other pertinent information

- c. Subscription order form, including rate schedules and fees for extra services
 - d. Los Angeles County Exclusive Commercial Franchise System and Service Area information
 - e. Billing information and customer service center location
 - f. Customer Bill of Rights and Responsibilities
 - g. Newsletter
 - h. Service Brochure
 - i. State waste Diversion goals and mandates
 - j. Education material for training purposes on how-to properly Recycle Organic Waste and Recyclables
 - k. Food DROP Program information
3. Annual outreach (bilingual)
 - a. Provide customers education and outreach material to maximize Diversion of Recyclables, Organic Waste (both Food and Green Waste), Bulky Items, Sharps, and E-waste
 4. Biannual newsletter
 5. Non-Collection Notices
 6. Container Labels
 7. Notices for corrections or issues if necessary
 8. Social Media signage, posts; and
 9. Any other material CONTRACTOR wants to provide.

EXHIBIT 17 – Contractor Documentation

All documentation listed below is to be attached to CONTRACT as Exhibit 17. Use of Director provided templates is required where applicable.

A. Notice to Director Required

1. CONTRACTOR's Permit and Permit Application

Include all Permits required by County Code (such as a waste collector Permit from County Department of Public Health) or other Applicable Law. Including Green Waste Quarantine Zone Agreement with CDFA.

2. Container Specifications

Include Container capacity options, color, manufacturer's orders and invoices, label content and placement (item C of Exhibit 3A1).

3. Vehicle Specifications

Include vehicle identification number, model, make, year, purchase order (if applicable) and fuel type.

4. Subcontractors

Include Subcontractors' names, the amount of Goods or Services less than \$50,000 that each Subcontractor provides to CONTRACTOR, and a description of CONTRACTOR's relationships to each Subcontractor, including ownership interests; but excluding Director-approved Subcontractors (Part 5K of Exhibit 5).

5. Office Address

See Section 6A and Section 6B1, Contractor Office Hours.

B. Director Approval Required

1. Form of Non-Collection Notice (Item A5 of Exhibit 3A1)

2. Waiver of Liability

Include form of any waiver of liability (Section 4B1) and form of any Indemnification (Part 2 of Exhibit 5)

3. Terms and Conditions Summary (Item I1 of Exhibit 3A1)

a. *Subscription Order Form*

b. Bill of Rights

4. Unpermitted Waste Screening Protocol (Section 13)

5. Acknowledgment

Receipt of fact sheets relating to form of Nonemployee Injury Report (Part 2B6 of Exhibit 5) and Safely Surrendered Baby Law (Part 8B2 of Exhibit 5).

6. Insurance and Performance Assurance (Part 4 of Exhibit 5 and Section 15)

7. Internal Revenue Service Notice 1015 (Part 8B1 of Exhibit 5)

8. CONTRACTOR's EEO Certification (Part 8D3 of Exhibit 5)

9. Sharps Collection (Item F1a of Exhibit 3A1)

10. Director-Approved Subcontractors

Include Subcontractors' names, the amount of Goods or Services more than \$50,000 that each Subcontractor provides to CONTRACTOR, and a description of CONTRACTOR's relationships to each Subcontractor, including ownership interests (Part 5K of Exhibit 5).

11. Backup Service Plan (Section 11C)

12. Key Personnel (Section 4J)

With contact information (name, address, Office and mobile phone numbers, e-mail address)

a. ALL CONTRACTOR MANAGERS (see definition of "Contractor Manager" in Attachment 5-9A)

b. AUTHORIZED REPRESENTATIVE OF CONTRACTOR (Part 5H of Exhibit 5)

c. SERVICES SAFETY OFFICIAL (Part 8E1 of Exhibit 5)

13. Route Maps

Route maps are to indicate all starting and ending points.

14. Collection Schedule (Item A4 of Exhibit 3A1)

CONTRACTOR to submit the final approved collection schedule for their designated Service Area.

15. Solid Waste Collection and Facilities

Designated by CONTRACTOR (item D of Exhibit 3A1), including the following information:

- Name, location, owner, and operator, with telephone contact;
- Types of materials accepted and rejected; and
- If applicable, methodology used by each Processing facility for allocating materials, including Disposed residue, to the Service Area, with sample Reports; and
- Reasons for changing the facility designation in the future; and
- Rate charged per ton of waste.
- Designated Solid Waste Facility Unavailable/Use of alternative Solid Waste Facility

CONTRACTOR is to put the rate that facilities will charge per ton for Disposal and Diversion at the start of the CONTRACT on Forms PW-2 and PW-3 and update the facility list and rates as they change.

CONTRACTOR may designate a new facility that has higher fees than the prior facility, but it may not pass increased costs to its Customers or the COUNTY by increasing the Service Rate. The Service Rate will not be adjusted to compensate CONTRACTOR if costs at the new facility are greater than those at the prior facility.

16. Additional CONTRACTOR Commitments

Those made in its proposal for procurement of this CONTRACT (item K of Exhibit 3A1).

17. Transition Roll-Out Plan (item H of Exhibit 3A1)

CONTRACTOR must provide a detailed transition plan for the following:

- Transition from the existing Non-Exclusive Commercial Franchise system to the Exclusive Commercial Franchise System
- Transition for the Exclusive Commercial Franchise System

18. Difficult to Service Occupants (Item L of Exhibit 3A1)

CONTRACTOR must explain to Director:

- What changes CONTRACTOR will make for alternative Collection, such as different Collection Vehicle or manual Collection.

19. Alternative Container Sizes (Item C14 of Exhibit 3A1)

CONTRACTOR to submit alternatives to Container sizes for Premises with space restrictions.

20. Movement of Green Waste

CONTRACTOR shall comply with all Applicable Laws regarding transportation of Green Waste, including the California Department of Food and Agriculture's (CDFA's) regulations that quarantine certain types of Green Waste and restrict its movement. See the following website for more information: (<https://www.cdfa.ca.gov/plant/pe/InteriorExclusion/quarantine.html>).

CONTRACTOR shall give Director a copy of either of the following:

- Application to CDFA for the agreement
- The completed CDFA agreement

21. Contamination Monitoring Plan

Include the approved Contamination Monitoring Plan (Item J1 of Exhibit 3A1)

22. Procurement of Recovered Organic Waste Products (Item J4 of Exhibit 3A1)

CONTRACTOR to submit their final approved procurement plan.

EXCLUSIVE COMMERCIAL FRANCHISE CONTRACT FOR THE AREA OF SAN GABRIEL VALLEY
WEST
EXHIBIT 17—CONTRACTOR DOCUMENTATION
A. NOTICE TO DIRECTOR REQUIRED
SIGNATURE PAGE 1 of 3

| TITLE | TOTAL NO. OF PAGES | CONTRACTOR INITIALS | COUNTY INITIALS |
|--|--------------------|---------------------|-----------------|
| A.1 Contractor's Permit and Permit Application | 3 | <i>JAN</i> | <i>CS</i> |
| A.2 Container Specifications | 20 | <i>JAN</i> | <i>CS</i> |
| A.3 Vehicle Specifications | 10 | <i>JAN</i> | <i>CS</i> |
| A.4 Subcontractors | 2 | <i>JAN</i> | <i>CS</i> |
| A.5 Office Address | 2 | <i>JAN</i> | <i>CS</i> |

Coley Skye

DIRECTOR

9/28/2022

DATE

Judith Helene Ware, Pres, CEO

CONTRACTOR
Wendy Lopez

9/20/2022

DATE

EXCLUSIVE COMMERCIAL FRANCHISE CONTRACT FOR THE AREA OF SAN GABRIEL VALLEY
WEST
EXHIBIT 17—CONTRACTOR DOCUMENTATION
B. DIRECTOR CONSENT REQUIRED
SIGNATURE PAGE 2 of 3

| TITLE | TOTAL NO. OF PAGES | CONTRACTOR INITIALS | COUNTY INITIALS |
|--|--------------------|---------------------|-----------------|
| B.1 Form on Non-Collection Notice | 2 | JAN | CS |
| B.2 Waiver of Liability | 3 | JAN | CS |
| B.3 Terms and Conditions Summary | 8 | JAN | CS |
| B.4 Unpermitted Waste Screening Protocol | 2 | JAN | CS |
| B.5 Acknowledgement | 2 | JAN | CS |
| B.6 Insurance and Performance Assurance | 14 | JAN | CS |
| B.7 Internal Revenue Service Notice 1015 | 2 | JAN | CS |
| B.8 Contractor's EEO Certification (Form PW-8) | 2 | JAN | CS |
| B.9 Sharps Collection | 2 | JAN | CS |
| B.10 Director-Approved Subcontractors | 2 | JAN | CS |
| B.11 Backup Service Plan | 3 | JAN | CS |
| B.12 Key Personnel | 2 | JAN | CS |
| B.13 Route Maps | 7 | JAN | CS |
| B.14 Collection Schedule | 3 | JAN | CS |
| B.15 Solid Waste Collection and Facilities | 4 | JAN | CS |
| B.16 Additional Contractor Commitments | 2 | JAN | CS |
| B.17 Transition Roll-Out Plan | 3 | JAN | CS |

EXCLUSIVE COMMERCIAL FRANCHISE CONTRACT FOR THE AREA OF SAN GABRIEL VALLEY
WEST
EXHIBIT 17—CONTRACTOR DOCUMENTATION
C. DIRECTOR CONSENT REQUIRED
SIGNATURE PAGE 3 of 3

| | | | | |
|------|---|----|------------|----|
| B.18 | Difficult to Service Occupants | 2 | <i>JAN</i> | CS |
| B.19 | Alternative Container Sizes | 2 | <i>JAN</i> | CS |
| B.20 | Movement of Green Waste | 13 | <i>JAN</i> | CS |
| B.21 | Contamination Monitoring Plan | 4 | <i>JAN</i> | CS |
| B.22 | Procurement of Recovered Organic Waste Products | 3 | <i>JAN</i> | CS |

Colin Skye

DIRECTOR

9/28/2022

DATE

John Andrew Wincelespalle

CONTRACTOR
President, CEO

9/20/22

DATE

Exhibit 17 – Contractor Documentation

Item A.1 - CONTRACTOR's Permit and Permit Application

This item consists of 3 pages (including this page).

Proof of Designation

Must be received by CalRecycle 30 days in advance of any designated collection activity.

I. Designation Participants Information

| | |
|--|----------------|
| Designating Local Government: City of Paramount | |
| Designated Approved Collector: e-Recycling of California - Paramount | CEWID#: 100376 |

II. Designation Collection Activity Details

| | |
|--|---------------------------------|
| Designation Beginning Date: 7/20/2022 | Designation End Date: 8/31/2024 |
| Geographic Area of Service: City of Paramount City Limits | |
| Specific Site(s) for Permanent Drop-off Services: 7202 Petterson Lane, Paramount CA 90723 | |
| Specific Address(es) of Permanent Drop-off Services: <input type="checkbox"/> Check if attachment(s) are provided. | |
| Method and Description of Collection Activities (check all boxes that apply): <input checked="" type="checkbox"/> Permanent Drop-off <input checked="" type="checkbox"/> Curbside Service <input checked="" type="checkbox"/> Illegal Disposal Clean-up <input checked="" type="checkbox"/> Temporary Special Events <input type="checkbox"/> Other (specify): | |
| Description of Authorized Collection(s): Residents' CRTs, DEWs and various other electronic devices. | |

III. Signed Certification Statements

| | |
|--|-----------------------------------|
| Name of Designating Authority Representative: John Moreno | |
| Title: City Manager | |
| Phone: 562-220-2222 | E-Mail: jmoreno@paramountcity.com |
| Mailing address: 16400 Colorado Ave., Paramount CA 90723 | |
| As required under Title 14 CCR § 18660.49(b)(6): I am a designating authority authorized to execute agreements or contracts related to waste management on behalf of the Local Government. I have read and understand all applicable laws and regulations governing the Electronic Waste Recovery and Recycling Program. I agree that the Local Government shall operate in compliance with those applicable laws and regulations. I certify that the Proof of Designation contains true and correct information to the best of the designating authority's knowledge. | |
| Signature:  | Date Signed: 7/21/22 |

| | |
|---|-----------------------------------|
| Name of Local Government Point of Contact (if different from above): Wendy Macias | |
| Title: Public Works Manager | |
| Phone: 562-220-2111 | E-Mail: wmacias@paramountcity.com |
| Mailing address: 16400 Colorado Ave., Paramount CA 90723 | |

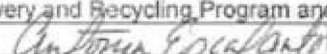
| | |
|---|---------------------------------------|
| Name of Authorized Collector Signatory: Antonia Escalante | |
| Title: Compliance Manager | |
| Phone: (800) 795-0993 x 413 | E-Mail: tescalante@erecyclingofca.com |
| Mailing address: 7230 Petterson Lane, Paramount, CA 90723 | |
| As required under Title 14 CCR § 18660.49(b)(9): I am an authorized signatory listed in the application for approval, and agrees to operate in compliance with the requirements of the Electronic Waste Recovery and Recycling Program and all applicable laws and regulations. | |
| Signature:  | Date Signed: 7/21/2022 |

FOR CALRECYCLE USE ONLY

| | | | |
|--|------------------|------------------|-----------------------|
| Transmitted by | Mail Received by | Date Transmitted | Date Eligible for Use |
| <input type="checkbox"/> Mail <input type="checkbox"/> Electronic Mail | | | |

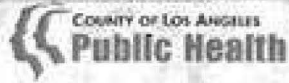

THIS PERMIT MUST BE CONSPICUOUSLY DISPLAYED ON THE PREMISES

Public Health Permit
Valid Until 12/31/2021



PR Number: PR0157340
Program ID: WARE DISPOSAL INC.
Description: SWF - WASTE COLLECTOR YARD FEE

Facility Owner - Mail Address
WARE DISPOSAL INC.
P.O. BOX 1319
SANTA ANA, CA 92702

Facility Location
WARE DISPOSAL, INC.
1451 MANHATTAN AVE
FULLERTON, CA 92831

SWA

Exhibit 17 – Contractor Documentation

Item A.2 - Container Specifications

This item consists of 20 pages (including this page).

Ware Disposal has the experience and capacity to collect and process all waste generated within each service area awarded using a three (3) single-stream system. This method of collection and processing will use a blue, green or brown, and black bin separation process which also includes wet and dry routes to maximize post-collection diversion and minimize contamination.

Ware Disposal will collect the following organic waste materials in accordance with SB 1383 guidelines:

Black or Brown Container: Organic food waste which means source separated food scraps, food-soiled paper and compostable plastics. Food waste is a subset of SSGCOW. "Food Scraps" means all food such as, but not limited to, fruits, vegetables, meat, poultry, seafood, shellfish, bones, rice, beans, pasta, bread, cheese, and eggshells. Food Scraps excludes fats, oils, grease when such materials are source separated from other food scraps. "Food-Soiled Paper" means compostable paper material that has come in contact with food or liquid, such as, but not limited to, compostable paper plates, paper coffee cups, napkins, pizza boxes, and milk cartons. Edible Food separated for food recovery will not be considered food waste. It is noted that food-soiled paper and plastics of any type are excluded from delivery of food wastes to the Puente Hill MRF since their Doda process cannot process such materials.



Green Container: “Yard trimmings” include all organic materials from the yard or landscaping such as plant trimmings, branches, and flowers, grass clippings, leaves and branches, fruits and vegetables, including only fruits or vegetables grown in your yard/garden that are whole, uneaten, and unprepared. All other food and food scraps should be placed in the black or brown bin for proper disposal. It is not expected that we will be collecting much in the way of green materials with the exception that single family residential properties may generate and have available materials. Typically, multifamily complexes and commercial premises have third-parties conduct landscaping work and usually require groundskeepers to haul away cut greens for recycling. In any event, Ware Disposal will work with all its accounts to assure that third-party landscapers recycle their collected materials. If they don’t, Ware Disposal will work with them and affected complexes to arrange for weekly green waste service using a roll off or other container.



GREEN BIN YARD WASTE

Note that only raw, unprepared fruit and vegetables are accepted in the green bin. Not accepted: cooked foods, meats, coffee grounds, and fruit peels, etc. Your green bin contents are made into compost and which is used in parks across the City.



(rest of page left blank intentionally)

Recycling Blue Container: “Paper” to include all clean dry paper; “cardboard” to include paperboard boxes and chipboard, cardboard boxes (broken down and flattened); “cartons” to include all refrigerated, shelf-stable, aseptic packaging; “metals” to include all aluminum, tin, metal, and bi-metal cans (wiped clean, if possible); “glass” to include all glass bottles and jars, wiped clean, if possible (including broken bottles); “plastics” to include all plastics numbers 1 through 7 (empty plastic containers, wiped clean, if possible), all clean plastic bags (grocery bags, dry cleaner bags, and film plastics), and car seats (cloth removed)



Ware Disposal will provide standard containers for all waste streams collected. We provide a summary of the containers in the table below.

| Service Area | Carts for SFRs, MFRs, & Commercial Premises | Containers SFRs, MFRs, & Commercial Premises |
|-------------------------|--|--|
| Gateway | See Attachment F | See Attachment F |
| Puente Hills | See Attachment F | See Attachment F |
| San Gabriel Valley East | See Attachment F | See Attachment F |
| San Gabriel Valley West | See Attachment F | See Attachment F |
| Wastestreams | Refuse (all sizes, black c) Recycling (all sizes, blue color) Green Waste (all sizes, if needed, green) Manure (65-gallon cart & 2 cys bin) Food Waste Cart (65-gallon only) | Refuse (all sizes, black color) Recycling (all sizes, blue color) Green Waste (all sizes, if needed, green) Manure (65-gallon cart & 2 cys bin) Food Waste Cart (65-gallon only) |
| Carts | Medium density polyethylene (MDPE) using a stress-free rotational molding process <ul style="list-style-type: none"> 32-gallon (70-pound maximum load capacity); | |

| | | |
|-------------------|--|---|
| | <ul style="list-style-type: none"> • 64-gallon (130-pound maximum load capacity; and, • 96-gallon (200-pound maximum load capacity. | |
| Bins | N/A | Steel Construction, 1 – 9 cys |
| Recycled Content | 50% - Carts | 80% Steel bins |
| Warranties | Available upon request | Available upon request |
| Age | New/like-new | New/like-new |
| Amortization | 8 to 10 years | 8 to 10 years |
| SB 1383 Compliant | Comply with SB 1383 requirements for purpose, color, identification and labeling | Comply with SB 1383 requirements for purpose, color, identification and labeling |
| Labels | An adhesive label will be affixed to the underside of the lid of each cart indicating the primary materials accepted and the primary materials prohibited for each container | An adhesive label will be affixed to the front of the container indicating the primary materials accepted and the primary materials prohibited for each container |

| | | |
|------------------|--|---|
| Container Labels | Every container will be appropriately labeled, with refuse, recyclables, organics labeling | All containers from the date of placement |
|------------------|--|---|

WARE

DISPOSAL, INC.

Providing Solid Waste and Recycling Services Since 1968

Trash Containers



Recycle Containers



Food Waste/Organics Containers



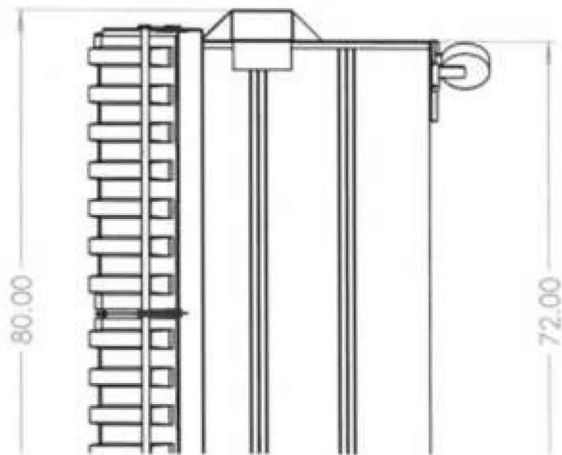
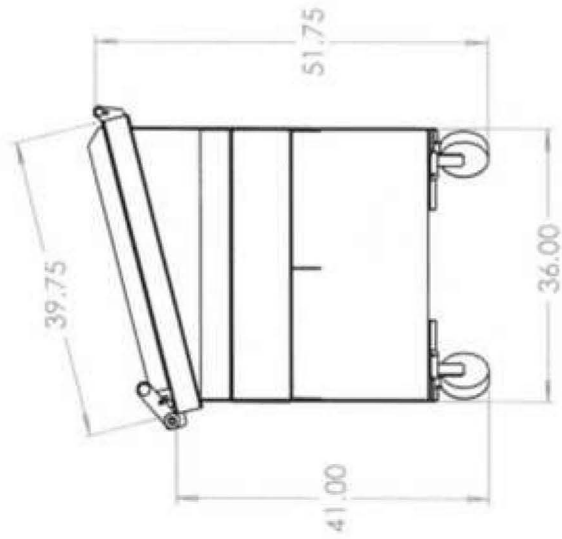
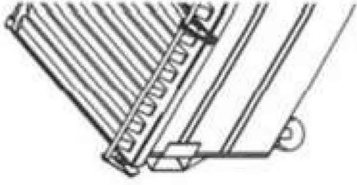

| | | |
|----|-----------|---------|
| P. | NAME | DATE |
| | BIZICI | 6/26/72 |
| | DRAWN | |
| | CHECKED | |
| | ENG. APPE | |
| | MFG. APPE | |



UNLESS OTHERWISE SPECIFIED:
 DIMENSIONS ARE IN INCHES
 UNLESS INDICATED
 FINISH IS
 TWO PLACE DECIMAL (0.125)

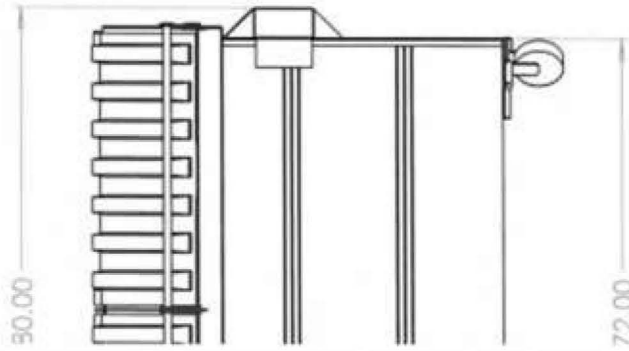
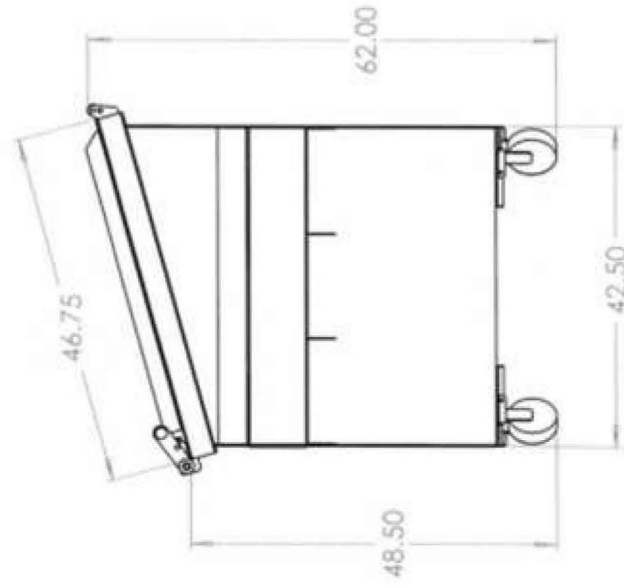
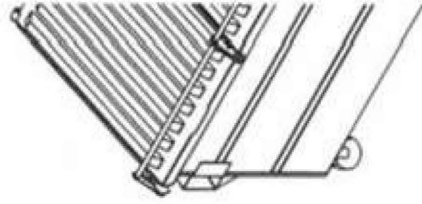

| | | |
|----|----------|---------|
| P: | NAME | DATE |
| | BUDICI | 6/28/22 |
| | DRAWN | |
| | CHECKED | 1 |
| | ENG APPR | |
| | MFG APPR | |
| | | |

UNLESS OTHERWISE SPECIFIED:
 DIMENSIONS ARE IN INCHES
 TOLERANCES:
 FRACTIONAL: AS SHOWN
 DECIMAL: .015
 TWO PLACE DECIMALS: .15
 HODGE MANUFACTURING COMPANY



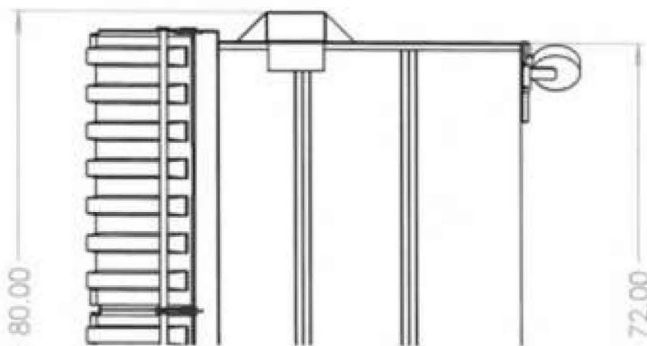
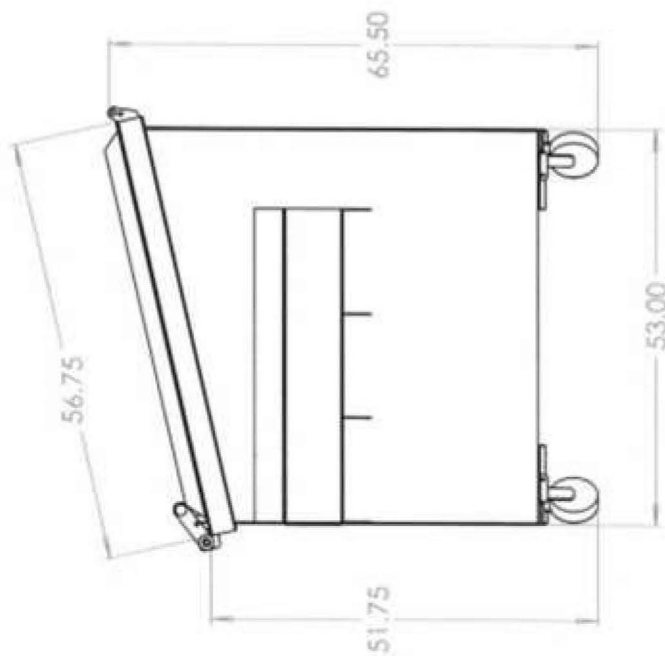
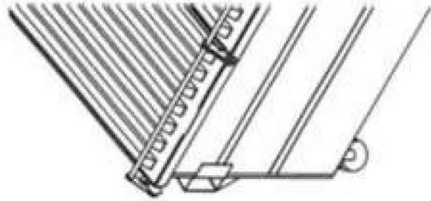

| | |
|------------|---------|
| P. | DATE |
| | 6/28/22 |
| NAME | BUDICKI |
| DRAWN | |
| CHECKED | |
| ENG. APPR. | |
| MFG. APPR. | |

UNLESS OTHERWISE SPECIFIED:
 DIMENSIONS ARE IN INCHES
 TOLERANCES:
 BEND ± .1"
 TWO PLACE DECIMAL #0.125





Quote

P.O. Box 1326
El Cajon, CA 92022-1326
(800) 778-2217

Order Number: 0381025
Order Date: 7/14/2022
Salesperson: RBH Riley
Customer Number: 0119114
Confirmation Date: 7/14/2022 12:00:48PM

Sold To:
WARE DISPOSAL
1451 MANHATTAN AVE
FULLERTON, CA 92831

Ship To:
WARE DISPOSAL
1451 MANHATTAN AVE
FULLERTON, CA 92831

Confirm To: EDDIE LARA

| Customer P.O. | Ship VIA HPI | F.O.B. | | Terms PREPAY | | | Price | Amount |
|--------------------|-----------------|---------|-----------|-----------------|------------|----------|--------|------------|
| Item Number | Unit | Ordered | Allocated | Shipped | Back Order | DropShip | | |
| *3 YARD STANDARD | EACH | 900.000 | 0.000 | 0.000 | 0.000 | N | 729.00 | 656,100.00 |
| *4 YARD STANDARD | EACH | 200.000 | 0.000 | 0.000 | 0.000 | N | 839.00 | 167,800.00 |
| *2 YARD STANDARD | EACH | 200.000 | 0.000 | 0.000 | 0.000 | N | 606.00 | 121,500.00 |
| *1.5 YARD STANDARD | EACH | 100.000 | 0.000 | 0.000 | 0.000 | N | 559.00 | 55,900.00 |

Order Comments:
INCLUDES 6" SWIVEL POLY CASTERS AND LOCK BARS

Order will ship complete. If any item is on backorder or dropship, the estimated delivery date is 10 to 15 business days from the date of order confirmation unless otherwise noted.

REMIT TO:
HODGE PRODUCTS, INC.
P.O. BOX 1326
EL CAJON, CA 92022-1326

Credit Card Authorization: 0.00
Card Type: CHECK
Last4:
Auth Amount: \$-

Net Order: 1,001,600.00
Less Discount: 0.00
Shipping & Handling: 0.00
Sales Tax: 77,624.00
Order Total: 1,079,224.00

hpionline.com | masterlocks.com | americanlocks.com | a2zhardware.com | buildalock.com



P.O. Box 1326
 El Cajon, CA 92022-1326
 (800) 778-2217

Quote

Order Number: 0381023
Order Date: 7/14/2022
Salesperson: RBH Riley
Customer Number: 0119114
Confirmation Date: 7/14/2022 12:01:45PM

Sold To:
 WARE DISPOSAL
 1451 MANHATTAN AVE
 FULLERTON, CA 92831

Ship To:
 WARE DISPOSAL
 1451 MANHATTAN AVE
 FULLERTON, CA 92831

Confirm To: EDDIE LARA

| Customer P.O. | Ship VIA HPI | F.O.B. | | Terms PREPAY | | | Price | Amount |
|-----------------|-----------------|---------|-----------|-----------------|------------|----------|--------|------------|
| Item Number | Unit | Ordered | Allocated | Shipped | Back Order | DropShip | | |
| *3 YARD LIGHT | EACH | 900.000 | 0.000 | 0.000 | 0.000 | N | 658.00 | 593,100.00 |
| *4 YARD LIGHT | EACH | 200.000 | 0.000 | 0.000 | 0.000 | N | 729.00 | 145,800.00 |
| *2 YARD LIGHT | EACH | 200.000 | 0.000 | 0.000 | 0.000 | N | 569.00 | 113,800.00 |
| *1.5 YARD LIGHT | EACH | 100.000 | 0.000 | 0.000 | 0.000 | N | 519.00 | 51,900.00 |

Order Comments:
 INCLUDES 6" SWIVEL POLY CASTERS AND LOCK BARS

Order will ship complete. If any item is on backorder or dropship, the estimated delivery date is 10 to 15 business days from the date of order confirmation unless otherwise noted.

REMIT TO:
HODGE PRODUCTS, INC.
 P.O. BOX 1326
 EL CAJON, CA 92022-1326

Credit Card Authorization: 0.00
Card Type: CHECK
Last4:
Auth Amount: \$-

Net Order: 904,600.00
Less Discount: 0.00
Shipping & Handling: 0.00
Sales Tax: 70,106.50
Order Total: 974,706.50

hpionline.com | masterlocks.com | americanlocks.com | a2zhardware.com | buildalock.com



Invoice

P.O. Box 1326
 El Cajon, CA 92022-1326
 (800) 778-2217

Order Number: 0381479
 Order Date: 7/28/2022
 Salesperson: RBH Riley
 Customer Number: 0119114
 Confirmation Date: 7/29/2022 4:34:11PM

Sold To:
 WARE DISPOSAL
 1451 MANHATTAN AVE
 FULLERTON, CA 92831

Ship To:
 WARE DISPOSAL
 1451 MANHATTAN AVE
 FULLERTON, CA 92831

Confirm To: eddie lara

| Customer P.O. | Ship VIA | F.O.B. | Terms |
|---------------|----------|--------|--------|
| | HFI | | PREPAY |

| Item Number | Unit | Ordered | Allocated | Shipped | Back Order | DropShip | Price | Amount |
|------------------|------|-----------|-----------|---------|------------|----------|--------|------------|
| *3 YARD STANDARD | EACH | 1,050.000 | 0.000 | 0.000 | 0.000 | N | 729.00 | 765,450.00 |

Item Comments:
 PAINTED BLACK

| | | | | | | | | |
|------------------|------|---------|-------|-------|-------|---|--------|------------|
| *3 YARD STANDARD | EACH | 200.000 | 0.000 | 0.000 | 0.000 | N | 729.00 | 145,800.00 |
|------------------|------|---------|-------|-------|-------|---|--------|------------|

Item Comments:
 PAINTED BLUE

Order Comments:

INCLUDES 6" SWIVEL POLY CASTERS AND LOCK BARS

Order will ship complete. If any item is on backorder or dropship, the estimated delivery date is 10 to 15 business days from the date of order confirmation unless otherwise noted.

REMIT TO:
HODGE PRODUCTS, INC.
 P.O. BOX 1326
 EL CAJON, CA 92022-1326

Credit Card Authorization: 0.00
 Card Type: CHECK
 Lock#:
 Auth Amount: \$-

| | |
|----------------------|-------------------|
| Net Order: | 911,250.00 |
| Less Discount: | 0.00 |
| Shipping & Handling: | 0.00 |
| Sales Tax: | 70,621.88 |
| Balance Due: | 981,871.88 |

hponline.com | masterlocks.com | americanlocks.com | a2zhardware.com | buildalock.com



Invoice

P. O. Box 1326
 El Cajon, CA 92022-1326
 (800) 778-2217

Order Number: 0381480
 Order Date: 7/28/2022
 Salesperson: RBH Riley
 Customer Number: 0119114
 Confirmation Date: 7/29/2022 4:34:37PM

Sold To:
 WARE DISPOSAL
 1451 MANHATTAN AVE
 FULLERTON, CA 92831

Ship To:
 WARE DISPOSAL
 1451 MANHATTAN AVE
 FULLERTON, CA 92831

Confirm To: eddie lara

| Customer P.O. | Ship VIA | F.O.B. | | Terms | | | Price | Amount |
|------------------|----------|---------|-----------|---------|------------|----------|--------|-----------|
| | HPI | | | PREPAY | | | | |
| Item Number | Unit | Ordered | Allocated | Shipped | Back Order | Dropship | Price | Amount |
| *8 YARD STANDARD | EACH | 12.000 | 0.000 | 0.000 | 0.000 | N | 929.00 | 11,148.00 |

Item Comments:
 PAINTED BLACK - INCLUDES 8" SWIVEL POLY CASTERS AND LOCK BARS

Order will ship complete. If any item is on backorder or dropship, the estimated delivery date is 10 to 15 business days from the date of order confirmation unless otherwise noted.

REMIT TO:
 HODGE PRODUCTS, INC.
 P.O. BOX 1326
 EL CAJON, CA 92022-1326

Credit Card Authorization: 0.00
 Card Type: CHECK
 Last: _____
 Auth Amount: \$-

| | |
|----------------------|------------------|
| Net Order: | 11,148.00 |
| Less Discount: | 0.00 |
| Shipping & Handling: | 0.00 |
| Sales Tax: | 863.97 |
| Balance Due: | 12,011.97 |

hpionline.com | masterlocks.com | americanlocks.com | a2zhardware.com | buildalocke.com



Invoice

P.O. Box 1326
 El Cajon, CA 92022-1326
 (800) 778-2217

Order Number: 0381504
 Order Date: 7/29/2022
 Salesperson: RBH Riley
 Customer Number: 0119114
 Confirmation Date: 7/29/2022 4:35:02PM

Sold To:
 WARE DISPOSAL
 1451 MANHATTAN AVE
 FULLERTON, CA 92831

Ship To:
 WARE DISPOSAL
 1451 MANHATTAN AVE
 FULLERTON, CA 92831

Confirm To: eddie lara

| Customer P.O. | Ship VIA | F.O.B. | Terms | | | | | |
|--|----------|---------|-----------|---------|------------|----------|--------|------------|
| | HPI | | PREPAY | | | | | |
| Item Number | Unit | Ordered | Allocated | Shipped | Back Order | DropShip | Price | Amount |
| *4 YARD STANDARD | EACH | 120.000 | 0.000 | 0.000 | 0.000 | N | 839.00 | 100,680.00 |
| Item Comments: PAINTED BLACK | | | | | | | | |
| *4 YARD STANDARD | EACH | 10.000 | 0.000 | 0.000 | 0.000 | N | 839.00 | 8,390.00 |

Item Comments:
 PAINTED BLUE

Order Comments:
 INCLUDES 6" SWIVEL POLY CASTERS AND LOCK BARS

Order will ship complete. If any item is on backorder or dropship, the estimated delivery date is 10 to 15 business days from the date of order confirmation unless otherwise noted.

REMIT TO:
HODGE PRODUCTS, INC.
 P.O. BOX 1326
 EL CAJON, CA 92022-1326

Credit Card Authorization: 0.00
 Card Type: CHECK
 Lock:
 Auth Amount: \$-

Net Order: 109,070.00
 Less Discount: 0.00
 Shipping & Handling: 0.00
 Sales Tax: 8,452.93
Balance Due: 117,522.93

hpionline.com | masterlocks.com | americanlocks.com | a2zhardware.com | buildalock.com



Invoice

P.O. Box 1328
 El Cajon, CA 92022-1328
 (800) 778-2217

Order Number: 0381505
 Order Date: 7/29/2022
 Salesperson: RBH Risky
 Customer Number: 0119114
 Confirmation Date: 7/29/2022 4:35:28PM

Sold To:
 WARE DISPOSAL
 1451 MANHATTAN AVE
 FULLERTON, CA 92831

Ship To:
 WARE DISPOSAL
 1451 MANHATTAN AVE
 FULLERTON, CA 92831

Confirm To: oddie lais

| Customer P.O. | Ship VIA | F.O.B. | Terms |
|---------------|----------|--------|--------|
| | HPI | | PREPAY |

| Item Number | Unit | Ordered | Allocated | Shipped | Back Order | DropShip | Price | Amount |
|---------------|------|---------|-----------|---------|------------|----------|--------|-----------|
| *2 YARD LIGHT | EACH | 155.000 | 0.000 | 0.000 | 0.000 | N | 579.00 | 89,745.00 |

Item Comments:
 PAINTED BLACK

| | | | | | | | | |
|---------------|------|--------|-------|-------|-------|---|--------|-----------|
| *2 YARD LIGHT | EACH | 40.000 | 0.000 | 0.000 | 0.000 | N | 579.00 | 23,160.00 |
|---------------|------|--------|-------|-------|-------|---|--------|-----------|

Item Comments:
 PAINTED BLUE

Order Comments:

INCLUDES 6" SWIVEL POLY CASTERS AND LOCK BARS

Order will ship complete. If any item is on backorder or dropship, the estimated delivery date is 10 to 15 business days from the date of order confirmation unless otherwise noted.

REMIT TO:
HODGE PRODUCTS, INC.
 P.O. BOX 1328
 EL CAJON, CA 92022-1328

Credit Card Authorization: 0.00
 Card Type: CHECK
 Lock:
 Auth Amount: 0-

Net Order: 112,905.00
 Less Discount: 0.00
 Shipping & Handling: 0.00
 Sales Tax: 8,750.14
Balance Due: 121,655.14

hpionline.com | masterlocks.com | americanlocks.com | a2zhardware.com | buildalock.com



Invoice

P.O. Box 1328
 El Cajon, CA 92022-1328
 (800) 776-2217

Order Number: 0381478
 Order Date: 7/29/2022
 Salesperson: RBH Riley
 Customer Number: 0119114
 Confirmation Date: 7/29/2022 4:33:40PM

Sold To:
 WARE DISPOSAL
 1451 MANHATTAN AVE
 FULLERTON, CA 92831

Ship To:
 WARE DISPOSAL
 1451 MANHATTAN AVE
 FULLERTON, CA 92831

Confirm To: eddie lara

| Customer P.O. | Ship VIA | F.O.B. | Terms | | | | | |
|-------------------|----------|---------|-----------|---------|------------|----------|----------|-----------|
| | HPI | | PREPAY | | | | | |
| Item Number | Unit | Ordered | Allocated | Shipped | Back Order | Dropship | Price | Amount |
| *18 YARD ROLL OFF | EACH | 10,000 | 0,000 | 0,000 | 0,000 | N | 6,500.00 | 65,000.00 |

Order will ship complete. If any item is on backorder or dropship, the estimated delivery date is 10 to 15 business days from the date of order confirmation unless otherwise noted.

REMIT TO:
HODGE PRODUCTS, INC.
 P.O. BOX 1328
 EL CAJON, CA 92022-1328

Credit Card Authorization: 0.00
 Card Type: CHECK
 Last4:
 Auth Amount: \$-

Net Order: 65,000.00
 Less Discount: 0.00
 Shipping & Handling: 0.00
 Sales Tax: 5,037.50
Balance Due: 70,037.50

hpionline.com | masterlocks.com | americanlocks.com | a2zhardware.com | buildalock.com

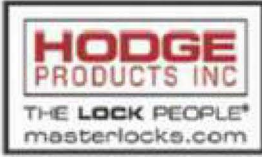

Invoice

P.O. Box 1328
 El Cajon, CA 92022-1328
 (800) 778-2217

Order Number: 0381477
 Order Date: 7/28/2022
 Salesperson: RBH Risky
 Customer Number: 0119114
 Confirmation Date: 7/29/2022 4:33:10PM

Sold To:
 WARE DISPOSAL
 1451 MANHATTAN AVE
 FULLERTON, CA 92831

Ship To:
 WARE DISPOSAL
 1451 MANHATTAN AVE
 FULLERTON, CA 92831

Confirm To: eddie lars

| | | | |
|---------------|-----------------|--------|-----------------|
| Customer P.O. | Ship VIA HPI | F.O.B. | Terms PREPAY |
|---------------|-----------------|--------|-----------------|

| Item Number | Unit | Ordered | Allocated | Shipped | Back Order | DropShip | Price | Amount |
|-------------------|------|---------|-----------|---------|------------|----------|----------|-----------|
| *10 YARD ROLL OFF | EACH | 10.000 | 0.000 | 0.000 | 0.000 | N | 6,250.00 | 62,500.00 |

Item Comments:
 10 YARD LOW BOY - STANDARD DUTY

Order will ship complete. If any item is on backorder or dropship, the estimated delivery date is 10 to 15 business days from the date of order confirmation unless otherwise noted.

REMIT TO:
HODGE PRODUCTS, INC.
 P.O. BOX 1328
 EL CAJON, CA 92022-1328

Credit Card Authorization: 0.00
 Card Type: CHECK
 Lock:
 Auth Amount: 0-

| | |
|----------------------|------------------|
| Net Order: | 62,500.00 |
| Less Discount: | 0.00 |
| Shipping & Handling: | 0.00 |
| Sales Tax: | 4,843.75 |
| Balance Due: | 67,343.75 |

hpionline.com | masterlocks.com | americanlocks.com | a2zhardware.com | buildalock.com

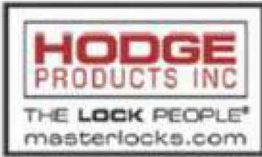

Invoice

P.O. Box 1326
 El Cajon, CA 92022-1326
 (800) 778-2217

Order Number: 0381475
 Order Date: 7/29/2022
 Salesperson: RBH Riley
 Customer Number: 0119114
 Confirmation Date: 7/29/2022 4:32:32PM

Sold To:
 WARE DISPOSAL
 1451 MANHATTAN AVE
 FULLERTON, CA 92831

Ship To:
 WARE DISPOSAL
 1451 MANHATTAN AVE
 FULLERTON, CA 92831

Confirm To: eddie lara

| Customer P.O. | Ship VIA | F.O.B. | Terms |
|---------------|----------|--------|--------|
| | HPI | | PREPAY |

| Item Number | Unit | Ordered | Allocated | Shipped | Back Order | DropShip | Price | Amount |
|------------------|------|---------|-----------|---------|------------|----------|----------|------------|
| 48 YARD ROLL OFF | EACH | 15.000 | 0.000 | 0.000 | 0.000 | N | 8,250.00 | 123,750.00 |

Order will ship complete. If any item is on backorder or dropship, the estimated delivery date is 10 to 15 business days from the date of order confirmation unless otherwise noted.

REMIT TO:
HODGE PRODUCTS, INC.
 P.O. BOX 1326
 EL CAJON, CA 92022-1326

Credit Card Authorization: 0.00
 Card Type: CHECK
 Lock#: _____
 Auth Amount: \$-

Net Order: 123,750.00
 Less Discount: 0.00
 Shipping & Handling: 0.00
 Sales Tax: 9,590.63
Balance Due: 133,340.63

hpionline.com | masterlocks.com | americanlocks.com | a2zhardware.com | buildalock.com

Exhibit 17 – Contractor Documentation

Item A.3 - Vehicle Specifications

This item consists of 10 pages (including this page).



www.VelocityTruckCenters.com

SALES
 Tel: 714 (926) 673-0570
 Reception (926) 510-4000

PARTS (927) 229-8252
SERVICE (926) 365-8157
COLUSIUM CENTER (926) 510-4000
 10000 Wilshire Blvd, Torrance, CA 90503

Buyers Order

Deal#: DE-95443
 Opp#: 2022-141685
 Date: 08/05/2022

Contact: Ron Creighton - Mobile: 562/755-6108 - Email: RCreighton@vvgtruck.com

Bill To: 108520
 WARE DISPOSAL INC
 PO BOX 1318
 SANTA ANA CA 92702 County: Orange
 Phone: (714) 644-0677 FAX: (714) 664-0696
 jay@waredisposal.com

Ship To:
 WARE DISPOSAL INC.
 1035 E. 4TH. ST.
 SANTA ANA CA 92701

| | | | | |
|--|---------|--------------------------------|-------------|--------------|
| Unit#: | Stock#: | New 2023 CRANE CARRIER LET2-40 | Price: | \$471,061.00 |
| VIN: FACTORY ORDER0 | | GVW: 53000 | Color: RED | |
| 1. HEIL RAPID RAIL 26 CY ASL FOR BEV QUOTE # BE122-010 | | | | |
| To Be Delivered On or About:06/11/2023 | | | Unit Price: | \$669,961.00 |
| Unit#: | Stock#: | New 2023 CRANE CARRIER LET2-40 | Price: | \$471,061.00 |
| VIN: FACTORY ORDER1 | | GVW: 53000 | Color: RED | |
| 1. HEIL RAPID RAIL 26 CY ASL FOR BEV QUOTE # BE122-010 | | | | |
| To Be Delivered On or About:06/11/2023 | | | Unit Price: | \$669,961.00 |
| Unit#: | Stock#: | New 2023 CRANE CARRIER LET2-40 | Price: | \$471,061.00 |
| VIN: FACTORY ORDER2 | | GVW: 53000 | Color: RED | |
| 1. HEIL RAPID RAIL 26 CY ASL FOR BEV QUOTE # BE122-010 | | | | |
| To Be Delivered On or About:06/11/2023 | | | Unit Price: | \$669,961.00 |
| Unit#: | Stock#: | New 2023 CRANE CARRIER LET2-40 | Price: | \$471,061.00 |
| VIN: FACTORY ORDER3 | | GVW: 53000 | Color: RED | |
| 1. HEIL RAPID RAIL 26 CY ASL FOR BEV QUOTE # BE122-010 | | | | |
| To Be Delivered On or About:06/11/2023 | | | Unit Price: | \$669,961.00 |
| Unit#: | Stock#: | New 2023 CRANE CARRIER LET2-40 | Price: | \$471,061.00 |
| VIN: FACTORY ORDER4 | | GVW: 53000 | Color: RED | |
| 1. HEIL RAPID RAIL 26 CY ASL FOR BEV QUOTE # BE122-010 | | | | |
| To Be Delivered On or About:06/11/2023 | | | Unit Price: | \$669,961.00 |
| Unit#: | Stock#: | New 2023 CRANE CARRIER LET2-40 | Price: | \$471,061.00 |
| VIN: FACTORY ORDER5 | | GVW: 53000 | Color: RED | |
| 1. HEIL RAPID RAIL 26 CY ASL FOR BEV QUOTE # BE122-010 | | | | |
| To Be Delivered On or About:06/11/2023 | | | Unit Price: | \$669,961.00 |
| Unit#: | Stock#: | New 2023 CRANE CARRIER LET2-40 | Price: | \$471,061.00 |
| VIN: FACTORY ORDER6 | | GVW: 53000 | Color: RED | |
| 1. HEIL RAPID RAIL 26 CY ASL FOR BEV QUOTE # BE122-010 | | | | |
| To Be Delivered On or About:06/11/2023 | | | Unit Price: | \$669,961.00 |

ONLY THOSE ITEMS AND SERVICES SPECIFICALLY WRITTEN ON THIS ORDER ARE INCLUDED IN THE STATED PRICE.
 ANY OTHER AGREEMENTS, UNLESS IN WRITING, ARE NOT BINDING ON SELLER.
 The numbered pages of this order comprise the entire agreement affecting this purchase and no other agreement or understanding of any nature concerning this purchase has been made or entered into, or will be recognized. I hereby certify that no credit has been extended to me for the purchase of this motor vehicle except as appears in writing on the face of this agreement. I have read and understand the final page of this agreement and agree to it as a part of this order the same as if it were printed above my signature. I certify that I am of legal age, or older, that I have legal capacity and authority to execute this agreement on behalf of my company, and hereby acknowledge receipt of a copy of this order.

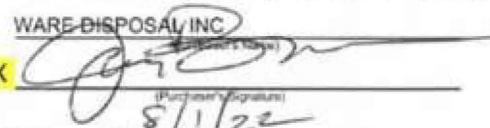
WARE DISPOSAL INC
 (Buyer's Name)
 X 
 (Purchaser's Signature)
 Date: 8/1/22

Ron Creighton
 (Salesperson Name)

 (Approved By)

 Date



www.velocitytruckcenters.com

SALES
 Tel/Fax (925) 673-8500
 Reception (925) 530-4300

PARTS (971) 722-6752
SERVICE (916) 346-4553
COLLECTION CENTER (925) 940-4100
 6800 Valley Blvd, Fontana CA 92330

Buyers Order

Deal#: DE-95443
 Opp#: 2022-141685
 Date: 08/05/2022

Contact: Ron Creighton - Mobile: 562/755-6108 - Email: RCreighton@vvgtruck.com

Bill To: 108520
 WARE DISPOSAL INC
 PO BOX 1318
 SANTA ANA CA 92702 County: Orange
 Phone: (714) 644-0677 FAX: (714) 664-0696
 jay@waredisposal.com

Ship To:
 WARE DISPOSAL INC.
 1035 E. 4TH. ST.
 SANTA ANA CA 92701

| Unit#: | Stock#: | Description | Price: |
|--|---------|---|---------------------------------|
| VIN: FACTORY ORDER7 | | New 2023 CRANE CARRIER LET2-40 GVW: 53000 Color: RED | \$471,061.00 |
| 1. HEIL RAPID RAIL 26 CY ASL FOR BEV QUOTE # BEI22-010 | | | \$198,900.00 |
| To Be Delivered On or About:06/11/2023 | | | Unit Price: \$669,961.00 |
| Unit#: | Stock#: | Description | Price: |
| VIN: FACTORY ORDERS | | New 2023 CRANE CARRIER LET2-40 GVW: 53000 Color: RED | \$471,061.00 |
| 1. HEIL RAPID RAIL 26 CY ASL FOR BEV QUOTE # BEI22-010 | | | \$198,900.00 |
| To Be Delivered On or About:06/11/2023 | | | Unit Price: \$669,961.00 |
| Unit#: | Stock#: | Description | Price: |
| VIN: FACTORY ORDER | | New 2023 CRANE CARRIER LET2-40 GVW: 53000 Color: RED | \$471,061.00 |
| 1. HEIL RAPID RAIL 26 CY ASL FOR BEV QUOTE # BEI22-010 | | | \$198,900.00 |
| To Be Delivered On or About:06/11/2023 | | | Unit Price: \$669,961.00 |

| | | |
|--|---------------------------------|-----------------------|
| | Sub Total | \$6,699,610.00 |
| | Doc Fee | \$850.00 |
| | CA Tire Recycle Fee | \$175.00 |
| | = NET FET (10) Units | \$788,630.20 |
| | Sales Tax (9.250%) | \$619,792.55 |
| | CA License | \$62,210.00 |
| | Total Vehicle Sale Price | \$8,171,267.75 |
| | HVIP GRANT | -\$1,200,000.00 |
| | Net Total | \$6,971,267.75 |

FET (Each): \$79,477.32 - Tire Credit (Each): \$614.30

--To Invoice (10) Units Above @ \$817,126.78 Each--

Lienholder: None...

*** PRICING IS SUBJECT TO CHANGE DUE TO SUPPLY CHAIN AND PRODUCTION ISSUES. ***

ONLY THOSE ITEMS AND SERVICES SPECIFICALLY WRITTEN ON THIS ORDER ARE INCLUDED IN THE STATED PRICE.

ANY OTHER AGREEMENTS, UNLESS IN WRITING, ARE NOT BINDING ON SELLER.

The numbered pages of this Order comprise the entire agreement affecting this purchase and no other agreement or understanding of any nature concerning this purchase has been made or entered into, or will be recognized. I hereby certify that no credit has been extended to me for the purchase of this motor vehicle except as appears in writing on the face of this agreement. I have read and understand the final page of this agreement and agree to it as a part of this order the same as if it were printed above my signature. I certify that I am of legal age, or older, that I have legal capacity and authority to execute this agreement on behalf of my company, and hereby acknowledge receipt of a copy of this order.

WARE DISPOSAL INC
 (Purchaser's Name)

Ron Creighton
 (Salesperson Name)

X
 (Purchaser's Signature)

(Approved By)

Date

Date

Aug 6 2022 12:54AM

Page 2 of 3

This order is not valid unless signed and accepted by dealer

1. **TRADE-IN(S).** Purchaser shall deliver trade-in(s) in the same condition as at the time of inspection and appraisal by Seller reasonable wear and tear excepted, except as disclosed in the Agreement. Purchase represents that each truck shall be free and clear of all liens and encumbrances and warrants that the trade-in(s) are that type and condition described in this Agreement, including any attachments hereto.
2. **TERMS OF PAYMENT.** Unless otherwise agreed, net payment shall be due on delivery. Late payments shall bear interest at the rate of 18% per annum, or the maximum permitted by law, whichever is less. If acceptance of delivery is delayed by Purchaser, payment shall become due on the date when Seller is prepared to deliver. If the financial condition of Purchaser at any time does not, in the judgment of Seller, justify continuance of the work to be performed by Seller hereunder on the terms of payment as agreed upon, Seller may suspend such work, or postpone delivery, and require such assurances of Purchaser's performance as Seller deems adequate, including payment in advance, or Seller may cancel this order and shall receive reimbursement for its reasonable and proper cancellation charges. In the event of bankruptcy or insolvency of Purchaser, voluntary or involuntary, Seller shall be entitled to cancel any order then outstanding at any time and seek reimbursement for its reasonable and proper cancellation charges.
3. **CANCELLATION.** Purchaser may cancel this order only if Seller is able to cancel said order with the manufacturer, and only upon written notice. Upon cancellation or failure to accept delivery, Purchaser shall pay Seller reasonable cancellation charges and expenses, not to be less than Seller's out-of-pocket expenses including carrying costs.
4. **SALES AND OTHER TAXES.** Unless otherwise specified herein, Seller's price does not include federal excise, sales, use, or other taxes. Consequently, in addition to the price specified herein, the amount of any other excise, sales, use or other tax applicable to the sale or use of the trucks purchased hereunder shall be paid by Purchaser, or in lieu thereof Purchaser shall provide Seller with a tax exemption certificate acceptable to the taxing authorities. Purchaser agrees that all taxes related to this transaction, whether arising at the time of the transaction or in the future, are Purchaser's responsibility and further agrees to promptly pay any such taxes.
5. **DELIVERY.** All trucks furnished hereunder shall be delivered to Purchaser at the Seller's dealership location or other location as designated in this Agreement. Unless otherwise provided, delivery will be made via carriers and routes designated by manufacturer with freight charges to be included in the purchase price. Delivery dates are approximate and are based upon receipt of all necessary information from Purchaser. Seller shall not be liable for delays in delivery or manufacturing, or other causes beyond Seller's control.
6. **TECHNICAL CHANGES.** Purchaser acknowledges that the manufacturer and Seller reserve the right to change the specifications of the truck(s) at any time without obligation to make such changes in other trucks previously delivered to Purchaser. In addition, manufacturer and Seller reserve the right to make design changes and substitution of materials subsequent to the receipt of the order which, in manufacturer's or Seller's opinion are necessary to improve the truck. Purchaser agrees to accept any such changes as fulfillment of Seller's obligations under this order.
7. **REQUIRED EQUIPMENT.** This order shall be deemed to include, whether or not specified herein, all equipment or accessories required by the National Highway Traffic Safety Act or other regulations in effect at the time of order of receipt. It is agreed that any additional or different equipment not specified which is required at the time of delivery to meet the foregoing Act or other regulations will be added and the costs shall be paid by Purchaser. Purchaser understands that certain safety equipment is available that is not legally required and is available at Purchaser's request for an additional fee.
8. **TITLE AND REMEDIES.** Until full payment by Purchaser of all amounts due hereunder, Seller reserves the title to all equipment furnished hereunder. If Purchaser defaults in payment or performance hereunder or becomes subject to insolvency, receivership, or bankruptcy proceedings, or makes an assignment for the benefit of creditors, or without the consent of Seller voluntarily or involuntarily sells, transfers, leases, or permits any lien or attachment on the equipment delivered hereunder, Seller may treat all amounts then or thereafter owing hereunder by Purchaser as immediately due and payable (subject only to credits required by law) and Seller may repossess said equipment by any means available by law and shall enjoy any and all other remedies of a secured creditor under the Uniform Commercial Code. Purchaser shall execute and deliver to Seller such financing statements and other documents, as Seller may deem appropriate to evidence, perfect, and protect the priority of its security interest in the truck(s) subject to this order.
9. **GENERAL.** Any assignment by Purchaser of this order or any rights hereunder, without written consent of Seller, shall be void. Clerical errors in this order may be automatically corrected by giving written notice thereof to Purchaser by a duly authorized representative of Seller. No waiver, alteration, or modification of any of the provisions hereof shall be binding unless and until in writing and signed by a duly authorized representative of Seller. To the extent not covered by other terms herein, including terms of warranty and limitation of liability, etc., the provisions of the Uniform Commercial Code shall govern this sale.
10. **IMPORT TARIFFS:** Purchaser acknowledges that any import tariffs imposed by the government are the sole responsibility of the Purchaser and will result in an increase in the Seller's price equal to the amount of the obligatory tariff.

This Agreement (including by reference the provisions set out in manufacturer's standard warranty or warranties) shall constitute the entire agreement between Purchaser and Seller, and no understandings or obligations not expressly set forth herein or in manufacturer's standard warranty or warranties are binding upon Purchaser or Seller.

ALL WARRANTIES, IF ANY, BY A MANUFACTURER OR SUPPLIER OTHER THAN SELLER ARE THEIRS, NOT SELLER'S, AND ONLY SUCH MANUFACTURER OR OTHER SUPPLIER SHALL BE LIABLE FOR PERFORMANCE UNDER SUCH WARRANTIES. SELLER HEREBY DISCLAIMS ALL WARRANTIES, EXPRESS OR IMPLIED, INCLUDING ANY IMPLIED WARRANTIES OF MERCHANTABILITY OR FITNESS FOR A PARTICULAR PURPOSE.

Accepted and Agreed by: _____
(Company Name)

(Date)

Signor's Name and Title: _____
(Please Print Name and Title. Must be an Officer of the company Authorized to approve capital purchases.)

X _____
(Signature)

Aug 6 2022 12:54AM



116 East Railroad Avenue – Monrovia, CA 91016
Phone: 626-357-9771 – Fax: 626-357-9778
www.bwequipinc.com



We appreciate the opportunity to offer the following proposal:

Mr. Ron Creighton
Velocity Truck Centers
2429 S. Peck Rd.
Whittier, CA 90601

July 28, 2022
Quotation # BE122-010
Open Quote For CCC LET2 BEV Only

Heil Rapid Rail 26 Cubic Yard Automated Side Loader

Standard Equipment Features Included

- 3YD³ hopper (self-cleaning)
- 96 inch lift reach
- Lift capacity up to 1600 lbs.
- Body service props
- Tailgate service props
- Fully automatic tailgate latches
- Grease zerks - for entire system only
- O.I.G.A.I. front mount tandem vane pump system
- Lift cylinders cushioned up and down with chrome plated rods
- Chassis frame-mounted oil tank with level/temperature gauge and oil suction shut-off valve
- 3-micron return line filter with magnetic trap and in-cab filter bypass monitor
- 100-micron suction line strainer
- Abrasion-resistant hydraulic hoses
- In-cab packing controls, electric
- Electric in-cab lift controls, rocker style
- Electric in-cab hoist controls
- Cortex Controller™ with In-Sight™ diagnostic display
- In-cab tailgate controls, electric
- In-cab function and indicator lights
- Observation ladder
- Lift reach warning
- Backup alarm
- Backup and license plate lights
- LED Center mounted brake light
- LED Duplicate high and low mount stop, turn, and tail lights
- LED Mid-body turn signals
- LED FMVSS #108 clearance lights and reflectors
- ICC reflective tape
- Rear mud flaps - anti-sail/anti-splash
- Rear underride guard
- Rear camera bracket and flood lights - reverse activated
- Customer's choice of one color finish paint
- Standard 1-year (2,000 hours of operator) warranty
- ANSI Z 245.1-2012 Compliant
- Cavity coat and joint sealer
- Inside-body front closure
- Outside mounted upper packer lube line
- Safety Triangle
- 5 lb. In-cab fire extinguisher
- Upgraded carriage
- Heavy duty packet paddle with liquid containment shaft seals

Additional Equipment Features Included

- 60-90 gallon belt grabbers
- Hopper and lift work light kit
- Multi-function LED smart light kit for body
- Tailgate mounted rear amber strobe light
- In-cab rocker switch controls for lift, RH door mount
- Anti sail mud flaps ahead of rear tires
- Full factory mount at Heil
- Manually operated expanded metal hopper cover
- 20# underbody fire extinguisher
- Bumper mounted toolbox
- Extended tailgate seal
- Hopper mounted broom and shovel rack
- 3rd Eye digital and mobile six camera system
- Landall delivery from Alabama to California

Southern California's only authorized sales, parts, and service dealer serving the Counties of Santa Barbara, Ventura, Los Angeles, San Bernardino, Orange, Riverside, San Diego, and Imperial.

Quoted Pricing Per Unit

Heil Unit Price: \$ 169,260.00
Installation Labor: \$ 14,640.00 (Non-taxable)
Delivery Cost: \$ 15,000.00 (Non-taxable)

Total Quoted Price: \$ 198,900.00 Per Unit

Quotation, Delivery and Payment Terms

- Quoted prices will be honored for ninety (90) days from the date of this quotation.
- Estimated delivery is TBD between Heil and Crane Carrier Engineering.
- Standard payment terms are thirty (30) calendar days from the ship date from Heil Ft. Payne, AL.

We sincerely Thank You for the opportunity to offer this quotation and look forward to continuing our relationship with you for many years to come. Should you have any questions regarding any of the information contained in the proposal, please do not hesitate to contact me at any time.

Best Regards,



Nathan Anderson
Vice President - Sales
Bodyworks Equipment, Inc.

Southern California's only authorized sales, parts, and service dealer serving the Counties of Santa Barbara, Ventura, Los Angeles, San Bernardino, Orange, Riverside, San Diego, and Imperial.



Order Entry Form

2022 Pricing D

| | | | | | | | | | | | |
|---|--|------------------------|--|--|--|------------|--|---|--|---------------|--|
| Sales Region: Zone 5 | | Salesman: Chris Purvis | | P.O.N.: | | Source: NO | | United States | | Date: 7/13/22 | |
| Purchaser: LA Freightliner Fontana Address: 13800 Valley Blvd City/ST/ZIP: Fontana, CA 92335 Attn: Ron Creighton Telephone: 909-515-4406 Fax: | | | | For Sale To: <i>Wine Division</i> Address: 1035 E. 4th St City/ST/ZIP: Santa Ana, CA 92701 Attn: Jay Ware Telephone: 877-714-5273 Fax: | | | | OEFA: Rev: 1 Date: 07/14/2022 SN: Qty: 10 (Ten) Model: LET2-40 Spec: Standard Cab | | | |
| Vocation (ie. FL, RL, ASL, WSL, RO): All | | | | Body Make: Ili | | | | Body Model: Rapid Roll 26 CY | | | |
| Motor: Canada IHT410-100 Motor <i>Accessories:</i> <i>Accessories:</i> <i>Accessories:</i> Air Compressor: Scod Type Oilless 3.0KW Air Compressor Cooling System: Radiator w/Electr Fans - (M F Below Zero KL) <i>Accessories:</i> <i>Accessories:</i> ePTO: CASCADIA #A22502-8 SAE "B" PUMP/8" SHAFT <i>Accessories:</i> Battery Box/Batteries: Steel (3) Three GRP 31, 50 DCA Ea. Standard Location LH Side <i>Accessories:</i> <i>Accessories:</i> Charge System: Fleming River Disconnect Switch w/ Pilot Light J1772 CBB Charge Port, On Board 150AH Charger DC-DC Charger: DC-to-DC fast charge (up to 150MAH) Batteries: CATL Battery Pack (306 VWH) <i>Accessories:</i> <i>Accessories:</i> Trans. / Retarder: eDrive 2-Speed Control: Right Pushbutton MS/Auto Neutral: Forward Neutral System "A0" Function <i>Accessories:</i> <i>Accessories:</i> Propshafts: Sptor L/A Series SPL 170 Front Axle: DD000F <i>Accessories:</i> Brakes: Disc Brakes - Bands AOB22X Automatic <i>Accessories:</i> Wheels: Aluminum - Hub 22.5 X 9.00 315R022.5 TOYO M153 L / Z0 Tires: No Spare Wheel: No Front Suspension: Parabolic Taper Leaf 20K Steering Position: RH, Drive Only, TH / Telescope Column <i>Accessories:</i> Rear Axle: DS44P <i>Accessories:</i> Brakes: Disc Brakes 40-45,000 - Bands AOB22X Wheels: Aluminum - Hub 22.5 X 9.00 315R022.5 TOYO M153 L / Z0 Tires: 5.57 Ratio 72 MPH Limit Speed: 65 MPH Ratio/Max. Speed: Automatic Stack Adjusters: No Spare Wheel: No Retarder: No <i>Accessories:</i> Rear Suspension: HMX-400 43k w/ Shocks, V-45K-Axis Tag/Pusher: No Wheels: No Tires: No <i>Accessories:</i> Frame: 30" Single Rail RRR, 2,270,220 Bumper: Painted Steel <i>Accessories:</i> Wheel Base: 207" CACT+ 176 AF+ 103" ABS System: AS - 48 Air Tanks: (3) Three Steel Tanks Drain Valves: Centralized Drain Valves Pull Cords: Bendix BW AD-SEP, Heated Air Dryer: Schrader Valve, Dryer Location <i>Accessories:</i> <i>Accessories:</i> | | | | Cab Construction: LET2 RH, Drive Only, TH / Telescope Column Cab Type/Tilt Pump Standard: Standard Cab 12v Cab Tilt Assist Pump <i>Accessories:</i> Cab Exterior: Dual Tone, Air Horn Under Cab Cab View: Cab View w/ Master Lights LED Head Lamps: 3 Rear Windows: Cab Interior: Dual Fans Standard Air Conditioning: Dual Cab Fans Shro: Standard: Integrate w/Cab Dash & Heater System Accessories: AMFM Stereo WBYP/WMAUSS & PostBuswash <i>Accessories:</i> Doors / Windows: LH Bolt Electric, Roll-Down RH Bolt Electric, Roll-Down Windows: LH 16" x 7" S/S West Coast "A" RH 16" x 7" S/S West Coast "A" Spot Mirrors: LH & RH (2) 8" Round Convex Spct. (4) Total 2-Each Side Seats: LH RH Forward Sears Sentry Air Ride, Asphalt Gray Sears Sentry Air Ride, Asphalt Gray Instrumentation: <i>Accessories:</i> <i>Accessories:</i> Wipers/Wiper(s): Steam/Wind Wipers Cab Elec. Lighting: CCC Daytime Running Light <i>Accessories:</i> Accessories: LED Cab Clearance, Marker & Turn Signal Accessories: Cab Floor Light Accessories: Two-Way Radio Circuit Wiring, in Overhead Console <i>Accessories:</i> Accessories: Second Power Point Accessories: Personal Radio Connection Ports Back-Up Alarm: ECCC RMA-SOT 82-1 (7" 85(A) Max. Equipment: 10B Fire Extinguisher, Loose <i>Accessories:</i> Accessories: Triangle Warning Flt, Lamps Accessories: First Aid Kit, Mounted Accessories: Spare Keys, 6 Keys Total Accessories: Key Code C270 Accessories: 4DAS Safety System Finish Paint: Color: Custom ColorCode: Red Cab: Upper Cab Stripe: No Lower Cab Stripe: No Bumper: Black G2-2B1738 Bumper Stripe: No Frame: Black G2-2B1738 Battery Box: Fuel Tank: Alum Std Finish Clear Coat: No Front Wheels: 2-Sided Alum Std Finish Rear Wheels: 2-Sided Alum Std Finish Onsite Charger: No Charger Required Standard Chase Warranty 12 Months, Unlimited Miles DD000F 14796 & C06174/2601 Priority - 11/1/2022, 81 (pre-filled after SE No/30K M) Standard - 3 Year Motor/Battery Warranty Standard - 2 Year Drive Axle Warranty TOTAL PRICE PER VEHICLE TAXABLE TRANSACTION NO <input type="checkbox"/> EX <input type="checkbox"/> YES <input type="checkbox"/> Freight Rates Subject to a Fuel Surcharge and / or a price increase at time of delivery Terms C O D Net Cash prior to Delivery QUOTE GOOD FOR 60 DAYS FROM SUBMISSION | | | | | | | |
| Notes: Requested Delivery Date: | | | | | | | | | | | |

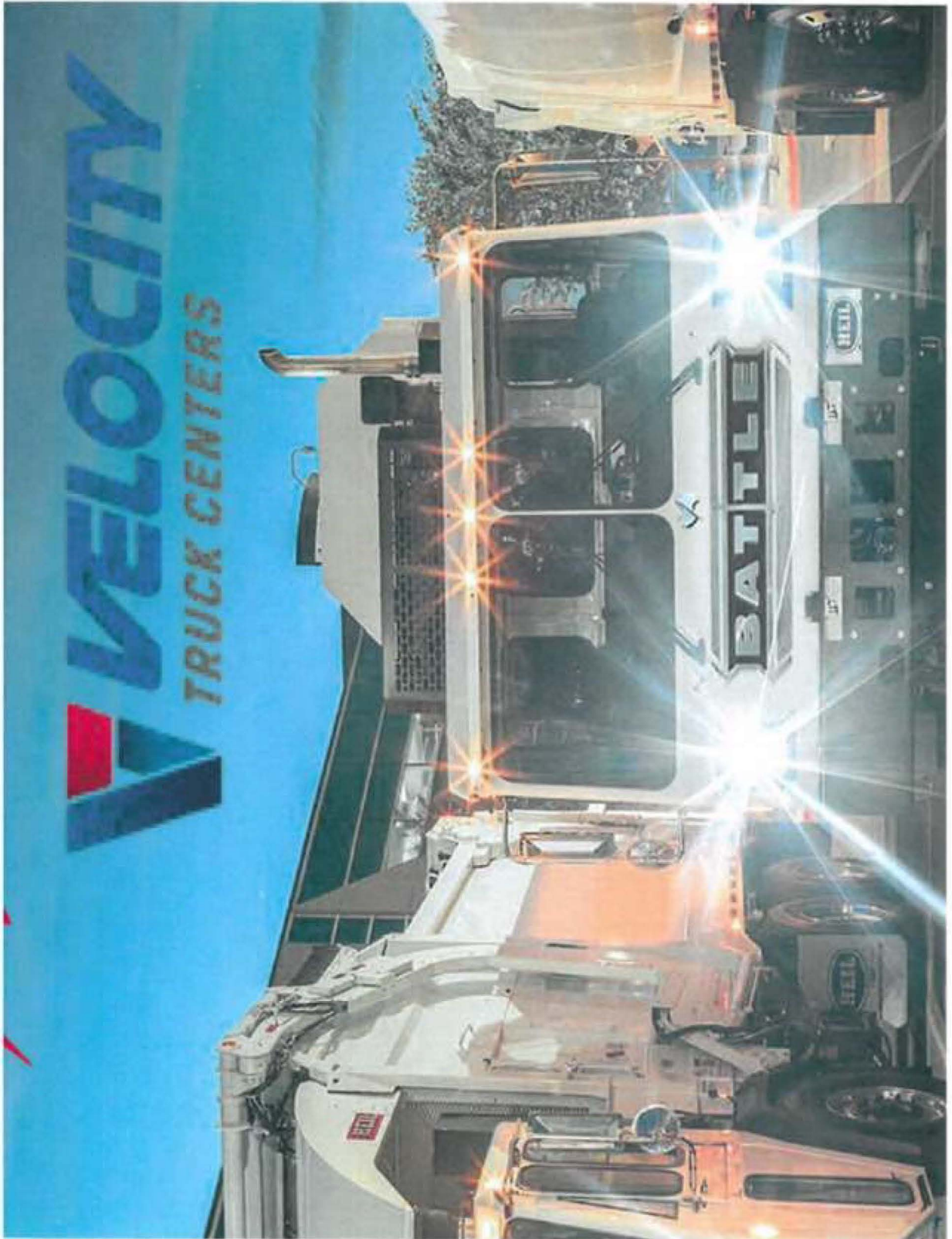

The following chart outlines the requested information for vehicles to be used in each selected franchise area: make, model, model year, type of fuel, waste sector collected, and number of vehicles for each service area proposed.

Table 6-2 Collection Vehicle Descriptions

| Service Area | Front End Loader | Roll Off | Boxbed Truck | Scout Utility |
|--|-------------------------|-----------------|---------------------|----------------------|
| Gateway/ No. of Vehicles | 6 | 1.5 | 1 | 1 |
| Puente Hills/ No. of Vehicles | 13 | 3 | 1 | 1 |
| San Gabriel Valley East/ No. of Vehicles | 8 | 1.5 | 1 | 1 |
| San Gabriel Valley West/ No. of Vehicles | 5 | 1 | 1 | 1 |
| Make | Peterbilt | Peterbilt | Isuzu | Isuzu |
| Model | 520 | 520 | -- | -- |
| Model Year | 2022 | 2022 | 2022 | 2022 |
| Type of Fuel | CRNG | CRNG | CRNG | CRNG |
| Safety Features | * | * | | |
| Waste Sectors | All | Commercial | Organics | As needed |

* GPS systems to show vehicle locations online/real time; PreView Side Defender®II "Right-hand" safety notification cameras and alert system; Safety labeling of trucks

Ware Disposal possesses its own CNG fueling infrastructure at its corporate yard located at 1451 Manhattan Avenue, Fullerton, California. All vehicles to be used in the County will be staged, refueled, and stored each night at this facility. Ware Disposal currently has an inventory of over 125 vehicles.

Our vehicles have features that enhance safety. These include:

Low overhead clearance by placing CNG equipment behind the cab rather than atop the truck body

Day and night vision cameras on each side of the truck and PreView Side Defender®II

Side guards

Enlarged side and cross view mirrors custom-fitted to the front of each truck to allow for a wider front and side view of the vehicle

Easily visible placarding and labeling

Dual-station cab with two nearly identical work environments including dual controls for the parking brakes, HVAC system and stereo

Angled console sides for easy visibility and access to the same controls and displays from the right and left

An enhanced HVAC system for improved airflow and climate control

Pantograph wipers that cover 27 percent more of the windshield than previous designs for increased safety during inclement weather



FORM PW-25.5

EQUIPMENT SPECIFICATION/PRODUCTIVITY ASSUMPTIONS
FOR THE EXCLUSIVE COMMERCIAL FRANCHISE CONTRACT FOR THE AREA OF SAN GABRIEL VALLEY WEST
 (This form may be reproduced in order to list all equipment)

| NUMBER OF TRUCKS | REFUSE | BULKY ITEMS | RECYCLING | ORGANIC WASTE | MIXED WASTE | FUEL TYPE |
|---|----------------------------------|----------------------------------|--------------------------------|--------------------------------|------------------------------|-----------|
| TRUCK TYPE (Front, side, or rear end, flatbed, pickup, etc.) | FRONT END LOAD SIDELOADER | FRONT END LOAD FLAT BED TRUCK | FRONT END LOAD SIDELOADER | FRONT END LOAD SIDELOADER | FRONT END LOAD SIDELOADER | CNG/DISEL |
| TRUCK CAPACITY/ COMPARTMENTS | 36 CY/10 TONS | 36CY/10 TONS 34CY/8 TONS | 36 CY/10 TONS | 36 CY/10 TONS | 36 CY/10 TONS | NA |
| NUMBER OF ROUTES (Including hours per route – shift) | UP TO 3 ROUTES 10 HOURS/ROUTE | 1 ROUTE 8 HOURS/ROUTE | 1-2 ROUTES 9-10 HOURS/ROUTE | 1-2 ROUTES 9-10 HOURS/ROUTE | 1 ROUTE 8-10 HOURS | NA |
| TRUCK TYPE (Front, side, or rear end, flatbed, pickup, etc.) | BURRO | NA | BURRO | BURRO | NA | CNG/CNG |
| TRUCK CAPACITY/ COMPARTMENTS | 12 CY/5 TONS | NA | 12 CY/5 TONS | NA | NA | NA |
| NUMBER OF ROUTES (Including hours per route – shift) | 1 ROUTE 9-10 HOURS/ROUTE | NA | 1 ROUTE 9-10 HOURS/ROUTE | 1 ROUTE 9-10 HOURS/ROUTE | NA | NA |
| TRUCK TYPE (Front, side, or rear end, flatbed, pickup, etc.) | | | | | | |
| TRUCK CAPACITY/ COMPARTMENTS | | | | | | |
| NUMBER OF ROUTES (Including hours per route – shift) | | | | | | |

Exhibit 17 – Contractor Documentation

Item A.4 - Subcontractors

This item consists of 2 pages (including this page).

Ware will not utilize any subcontractors.

Exhibit 17 – Contractor Documentation

Item A.5 - Office Address

This item consists of 2 pages (including this page).

WARE

DISPOSAL, INC.

Providing Solid Waste and Recycling Services Since 1968

Office Address:

955 N. Mission Rd.
Los Angeles, CA 90033

Yard Address:

955 N. Mission Rd.
Los Angeles, CA 90033

| Corporate Headquarters & Madison Materials | Corporate Yard for Vehicles |
|---|--------------------------------------|
| 1035 E. 4th Street, Santa Ana, CA | 1451 Manhattan Avenue, Fullerton, CA |

Office Hours:

Monday-Friday: 7am- 4:30pm

Saturdays: 7am-2pm

Ware website will allow for instant 24-hour communication and Emergency services after hours

Exhibit 17 – Contractor Documentation

Item B.1 - Form of Non-Collection Notice (Item A5 of Exhibit 3A1)

This item consists of 2 pages (including this page).



NON-COLLECTION NOTICE

877-714-WARE (9273)

Your trash and/or recyclables were not collected for one of the following reasons checked below:

- Non permitted waste such as tire, household hazardous waste, electronic waste, batteries and fluorescent tubes were placed in the containers.
- Unsafe Conditions _____
- Overfilled container
- Overweight container
- Food waste was contaminated with trash
- Recycling cart was contaminated with trash
- Container was not accessible, Time _____
- Your account is past due, Call Us.
- Bulky items placed outside of the container that were not scheduled to be serviced.
- Unable to locate Cart / Container
- Other _____

Your service day is _____

Call us if you have any questions.

ACCT #: _____ DATE: _____

ROUTE: _____ TRUCK: _____



Non Collection Notice

1 877 714 9273

- Unpermitted waste IE: tires, paint, batteries, hazardous wastes, fluorescent bulbs
- Unsafe conditions _____
- Overfilled container
- Overweight container
- Food waste contaminated with trash
- Recycle container contaminated with trash
- Container blocked time _____
- Your account is past due. Call US
- Bulky items outside container not scheduled
- Unable to locate cart/container

Your service day is _____

Call us if you have any questions

Account Number _____ Date _____

Route _____ Truck _____

Exhibit 17 – Contractor Documentation

Item B.2 - Waiver of Liability

This item consists of 3 pages (including this page).



**GENERAL RELEASE AND WAIVER OF LIABILITY
FOR DAMAGE TO
PRIVATE DRIVEWAYS AND PAVEMENT**

- 1. **PERMISSION TO ENTER.** Customer allows Ware Disposal Inc, its assigns, employees, agents, and subcontractors (“**Service Providers**”) to enter and/or utilize the premises of the undersigned Customer (“**Customer’s Premises**”) for the purposes of providing the solid waste services described on the attached Subscription Order. (“**Services**”).

- 2. **WAIVER OF LIABILITY SUBJECT TO SERVICE PROVIDERS’ NEGLIGENCE AND WILLFUL ACTS AND OMISSIONS.** Customer releases Service Providers from, and assumes the risk of, and waives all liability caused by, and claims, demands, actions, and causes of actions whatsoever against Service Provider for damage to Customer’s pavement (such as driveway and sidewalks).

This release is **subject to each Service Provider’s negligence and willful acts or omissions**, and the obligations of Service Provider to Customer under Service Provider’s Non-Exclusive Commercial Solid Waste Collection Franchise Agreement with the COUNTY OF LOS ANGELES, including our repair or replacement, to your satisfaction, of damaged property, and reimbursement of your cost of personal injury, caused by our negligence or willful acts or omissions.

- 3. **BINDING.** This acknowledgement, hold harmless, and release/assumption of risk shall be binding on all of Customer’s successors and administrators.

In signing this permission and release/assumption of risk/waiver, I hereby acknowledge and represent:

- a. That I have read this release, understand it and sign it voluntarily; and
- b. That I am the legal customer of the premises at the address provided below

For Customer

Ware Disposal, Inc

Printed

Printed

Date

Date

Customer’s Premises Address: _____

OR

Address of location where trash bin or container was placed:
(If different from address above)

Name/Title of Customer's Authorized Agent/Representative:

Signature of Customer's Authorized Agent/Representative: _____

Date: _____

Exhibit 17 – Contractor Documentation

Item B.3 - Terms and Conditions Summary (Item I1 of Exhibit 3A1)

This item consists of 8 pages (including this page).



Customer Subscription Order Form

**WARE DISPOSAL INC.
SAN GABRIEL VALLEY WEST**

COMMERCIAL TRASH, RECYCLING, AND ORGANIC WASTE COLLECTION SERVICES

CUSTOMER SUBSCRIPTION ORDER

To Our Valued Customer: The County of Los Angeles Board of Supervisors (County) awarded Ware Disposal Inc. a ten-year exclusive contract to provide commercial trash, recycling and organic waste collection service within the unincorporated community of San Gabriel Valley West starting on October 1, 2022, and ending September 31, 2032. Ware Disposal Inc. takes great pride in the work we do to keep the environment clean and protected for our future.

This subscription is subject to our being a franchised waste hauler under the County's exclusive commercial franchise contract. Its term is ten (10) years, *unless you terminate service*. You may terminate service at any time by giving us 14 days' notice, your notice must include a reason for the termination. We will refund any advanced payment for service after termination. We will provide a written final notice (postmarked at least 14 days in advance) if we are to suspend or terminate your service. The final notice will include an explanation for the suspension or termination and information on how to resolve your issue and restart service. For a general copy of your Bill of Rights, please visit www.LACountySWIMS.org/BOR.

CONTAINER TYPES, SIZES AND STANDARD SERVICE RATES

Please review the service option that you ordered and the rates we will charge you (on or after October 1, 2022), marked below. We will bill you monthly:

| SOLID WASTE TYPE | CONTAINER TYPE (Cart, Dumpster or Roll-off) | CONTAINER SIZE | COLLECTION FREQUENCY / WEEK | | | | | | |
|------------------|---|----------------|--|----|----|----|----|----|----|
| | | | 1. | 2. | 3. | 4. | 5. | 6. | 7. |
| Trash | | | [List the Collection Frequency per week selected by the customer along with the Service Rates] | | | | | | |
| Recycling | | | [List the Collection Frequency per week selected by the customer along with the Service Rates] | | | | | | |
| Organic Waste | | | [List the Collection Frequency per week selected by the customer along with the Service Rates] | | | | | | |
| Other: | | | [List the Collection Frequency per week selected by the customer along with the Service Rates] | | | | | | |

ADDITIONAL STANDARD SERVICES

All Customers will receive:

- Recycling Containers – One (1) 96-gallon cart for FREE
 - Additional or larger containers and capacity provided at HALF the trash rate
- Organic Waste Containers – One (1) 64-gallon cart for FREE
 - Additional or larger containers and capacity provided at the SAME rate as trash
- Container Cleanings
 - One (1) free container cleaning or container change out per 12-month period, per container
- Container Exchanges
 - One (1) free annual exchange of containers for different sizes
- Site Visits and Waste Assessments
 - All customers will receive a site visit and waste assessment upon start of collection services. Ongoing site visits and waste assessments shall be provided every other year thereafter or as needed.

Residential and Multifamily Customers will receive:

- In-home Food Waste Container (Limited one (1) per occupant)
- Free Holiday Tree Collection Services and Sharps collection
- Free annual on-call bulky item collections. The maximum amount of collections allotted depends on the number of units on the premises. (Single-family is considered one (1) unit)

Businesses will receive:

- Up to six (6) free on-call bulky item collections per year

DISCOUNT SERVICES

- 25% Senior Discount

EXTRA SERVICES

- Available Upon Request (See Attachment)

To request additional services, ask questions or express concerns, please call our customer service department:

CUSTOMER SERVICE

Monday thru Friday 8:00 a.m. to 5:00 p.m. at 1-877-714-9273 or email at info@wardisposal.com.

www.wardisposal.com

EXTRA SERVICES FEES

| Extra Service | Description | Fee |
|--|--|--|
| Locks | | |
| Padlock | Upon Customer Request | \$29.99 (one-time, per Container) |
| Gravity Lock | Upon Customer Request | \$155.00 (one-time, per Container) |
| Lock Bar | Upon Customer Request | \$110.00 (one-time, per Container) |
| Service | | |
| Roll-out | Upon Customer Request | \$17.49 per collection event; \$13.95 per container (beyond first container) |
| Scout | 25-50 ft | \$17.98 per collection event; \$14.98 per container (beyond first container) |
| | 51-75 ft | \$25.90 per collection event; \$18.90 per container (beyond first container) |
| | 76+ ft | \$34.99 per collection event; \$24.99 per container (beyond first container) |
| Difficult to Service | For Customers that live in difficult to service areas including but not limited to: areas with narrow streets, alleys and bridges, one-way narrow streets, steep roadway gradients, etc. | \$19.90 per collection event; \$15.90 per container (beyond first container) |
| Additional Bulky Item pickups for Multifamily and Residential Customers | After exceeding maximum Collections allowed per yr. | \$65.00 per pickup |
| Additional Bulky Item pickups for Commercial Customers | After exceeding 6 collections allowed per yr. | \$55.00 per pickup |
| Containers | | |
| <u>Bear Resistant Containers</u> 96-Gallon Cart | Upon Customer Request | \$52.25 per month |
| <u>Bear Resistant Containers</u> Other Container size (If available): <u>TO BE DETERMINED BETWEEN CLIENT AND WARE DISPOSAL INC.</u> | Upon Customer Request | \$49.40 per month |
| Cleaning or Exchange of Containers for cleaning purposes | After one free cleaning per 12-month period | \$61.75 per Cart or Dumpster Container |
| | | \$817.50 per Compactor Container |
| | | \$403.75 per Roll-off Container |
| Extra Pickup Charge, beyond 1 allowed per year | Unscheduled collection due to non-collection events | \$99.00 per occurrence |
| Container Violation Fee | For Unresponsive Customers or not rectified scenarios needing to collect Solid Waste materials subject to non-collection events | \$99.00 per occurrence |
| Contamination Fee | Upon observation and documentation of 3 rd contamination incident | \$65.00 per occurrence |
| Temporary Roll-off Daily Rental Fee (Excluding C&D) | Temporary Roll-off Daily Rental Fee | \$15.00 per day |

| | | |
|--|---|---|
| Container Removal and Return within previous 12 months (Containers in Public-Right-of Way) | For Removal of Carts or Dumpsters Stored in the Public Right-of-Way | \$25.00 First removal and return (per set) \$ <u>Additional 25% fee</u> Each additional removal and return (per set) \$145.00 Cleanup of Set-Out Site |
| Container Size Exchange, beyond 1 per year | Each additional exchange/delivery | \$25.00 Per each additional exchange |
| Construction and Demolition (C&D) Debris Roll-offs | | |
| C&D Roll-off Containers | Upon Customer Request | \$ <u>Negotiate rate with Customer</u> per month |
| Manure Service | | |
| 64-Gallon Cart | Upon Customer Request | \$65.00 per month/1x service per week |
| 1-CY Dumpster | Upon Customer Request | \$125.00 per month/1x service per week |
| 2-CY Dumpster | Upon Customer Request | \$139.00 per month/1x service per week |
| In-Home Food Waste Container | | |
| Additional in-home Food Waste Containers (First one Free) | Upon Customer Request | \$19.00 per Container |
| Green Waste Service | | |
| Green Waste only Containers (Carts and Dumpsters) | Upon Customer Request | \$ <u>Negotiate rate with Customer</u> per month |
| Billing | | |
| Late Payment Fee | If payment is not received by the last day of the second month, the account will become delinquent, and a late fee will be assessed | 10% of past due amount |
| Service Interruption | Additional Charge for Collection Services Interruption (returning containers back to premises) | \$25.00 |
| Returned Checks | Additional Charge for Customer returned checks (insufficient funds) | \$25.00 |



Bill of Rights

EXCLUSIVE COMMERCIAL FRANCHISE

CUSTOMER BILL OF RIGHTS

What We Will Collect. We will collect trash (also known as refuse), organic waste, and commingled recyclables in containers we provide. You must place refuse, recyclable materials, and organic waste in the appropriate collection containers. We may not pick up materials that are discarded outside of containers and as such may be considered a non-collection event unless you have made previous arrangements with us, as described below.

Mandatory Organic Waste Collection Services. The Los Angeles County Board of Supervisors adopted the Mandatory Organic Waste Disposal Reduction Ordinance, which enforces all persons (residents and business/property owners) in the County unincorporated communities to subscribe to organic waste collection services. To comply with this law, you may self-haul, self-manage organic waste on site, utilize an authorized Micro-Hauler (Limited to Organic Waste Collection Only), or you may choose to receive organic waste collection services with us. Additionally, all our customers will be provided a 64-gallon cart of weekly organic waste collection services at no additional charge, along with their weekly refuse collection services.

Should you need more containers, we can offer a variety of sizes at a cost. Please contact us for your needs.

Mandatory Commercial Recycling. Commercial businesses and multifamily residences (of 5 or more units) that generate four (4) cubic yards or more of solid waste per week are required by California law to recycle. To comply with the law, you may donate or sell any of, or all, your recyclables elsewhere, such as recycling centers or reuse enterprises, or subscribe to recycling services with us. Additionally, all our customers will be provided a 96-gallon cart of weekly recycling collection services at no additional charge, along with their weekly refuse collection services. Larger containers will be offered at half the rate for the same type and capacity of refuse container and same frequency of a refuse collection service. To evaluate and determine whether your existing levels of refuse, recycling, and organic waste services are appropriate, and promote and implement recycling services, a free site visit and waste assessment will be provided upon the start of collection services. Ongoing site visits and waste assessments will be provided every other year thereafter or as needed.

We Will Not Collect Hazardous Waste. State law prohibits disposal of hazardous materials in your collection containers. Hazardous waste includes most paints, pesticides, petroleum derivatives such as motor oil and solvents, batteries, thermostats, aerosol cans, fluorescent lights, and certain mercury-containing devices. If we identify these items in your containers, we will tag your containers and they will not be collected. For additional safe and legal disposal options, call 1 (888) CLEAN LA or visit www.CleanLA.com.

When We Will Collect. We will collect your containers on your scheduled collection day(s) each week. We will notify you in advance if we make a permanent change in your scheduled collection

day. If your scheduled collection day falls on or after a holiday, or during a holiday week, collection will be delayed by one (1) day. (Friday customers will receive their collection on Saturday.) We observe the following holidays: Memorial Day, Independence Day, Labor Day, Thanksgiving, Christmas, and New Year's Day.

Where We Will Pick Up. You must set your containers(s) at the set-out site as agreed upon unless you have roll-out/scout service. If we agreed to collect on private driveways or pavement, we will ask you to sign a waiver of damage liability. We must repair or replace, to your satisfaction, damaged property, and reimburse you for cost of personal injury caused by our negligence or willful acts or omissions. In addition to enforcing your rights under the franchise agreement, you may institute civil suits allowed under law.

Container Enclosure Maintenance and Litter. You are responsible for keeping your container enclosure or set-out site clean and in good repair. We will clean up all litter caused during collection.

Weight Limitations of Carts or Dumpsters. We will not pick up carts weighing more than 250 pounds or dumpsters weighing more than: Standard three (3) cubic yard dumpster=350 pounds.

Repair/Replacement. At no additional charge, we will repair or replace damaged containers within two service days after we have observed damaged containers while providing service and upon your request, unless the container damage is deemed to be due to customer negligence.

Bulky Items and Electronic Waste Pickups for Multifamily and Residential Customers. We will provide a specified maximum amount of bulky item pickups per year at no charge (limit of ten (10) items per pickup) based on the number of units on the premises, as specified in the chart below.

| Residential and Multifamily Premises with Number of Units | Maximum Collection Pickups (no additional cost to Customer) |
|--|--|
| MF Premises with 150+ units | Up to 50 per year No Charge |
| MF Premises with 101-149 units | Up to 40 per year No Charge |
| MF Premises with 50-100 units | Up to 30 per year No Charge |
| MF Premises with 25-49 units | Up to 20 per year No Charge |
| MF Premises with 1-24 units *1-unit accounts for a Residential Customer | Up to 10 per year No Charge |

Examples of bulky items include discarded furniture (such as chairs, sofas, mattresses, box springs, and rugs), appliances (such as refrigerators, ranges, washers, dryers, water heaters, dishwashers, plumbing), and other similar items. Electronic waste includes "covered electronic devices" such as cathode ray tubes (as in TV and computer monitors), LCD and plasma screens, and electrically powered equipment such as computers, telephones, answering machines, radios, stereo equipment, tape players/recorders, phonographs, videocassette players/recorders, and calculators.

The collection of special recyclable and reusable items such as textiles, wood and lumber are also included.

Bulky Items and Electronic Waste Pickups for Commercial Customers. We will make six (6) pickups of bulky items (limit of ten (10) items per pickup) and unlimited amounts of certain electronics at your request each year. If you call us at least 24 hours in advance, we will collect them on your next regularly scheduled pickup day.

When You Must Pay. We bill trash collection services monthly or quarterly in advance. We will mail your bill on or before the first day of your billing period, i.e., April 1st for the billing period of April, May, and June. Your bill is due no later than the last day of the first month. With this example, that would be April 30th. If we do not receive payment by the last day of the second month, i.e., May 31st, your bill will become delinquent and an additional 10% fee will be added to the balance. We may terminate your service if you do not pay your service fees by the end of the billing cycle, i.e., June 30th. We will charge \$25 to restart the service after a service interruption and a \$25 fee on returned checks.

Refunds. We will refund any overcharges (including advance payments for services that you subsequently cancel) within 30 days after we receive them. We will pay you interest on overcharges (other than advance payments for subsequently canceled services) at 10% per annum from the date of the overcharge until the date refunded.

Third Party Services. Customers have the option to obtain extra services such as: roll-out and scout service through another service provider.

Customer Termination Rights and Right to Self-haul. Within six (6) months of your new service, we will amend any written subscription order you may have with us to grant you your customer termination rights. You may terminate service at any time by giving us 14-days' notice, your notice must include a reason for the termination. You also have the right to self-haul some of, or all, your solid waste in addition to, or instead of, subscribing to our service.

Customer Notification. We will provide a written final notice (postmarked at least 14 days in advance) if we are to suspend or terminate your service. The final notice will include an explanation for the suspension or termination and information on how to resolve your issue and restart service.

Where You Can Contact Us. You may call us toll-free regarding service or complaints at 1 877 714 9273 between 08:00am and 05:00pm on weekdays, except holidays. You may come to our office located at 1035 East 4th Street, Santa Ana, California 92701-4750, mail correspondence to our office address or e-mail us at info@waredisposal.com. If we do not satisfactorily resolve any complaint, you may call Los Angeles County Public Works at 1-888-253-2652.

We Do Not Discriminate. If you are entitled to service, we will not discriminate against you on account of race, creed, color, sex, gender, national origin, ancestry, religion, age, physical or mental disability, marital status, or political affiliation.

Rights Of Privacy. We will observe and protect your rights of privacy and trade secrets. Unless you give us permission, we will not reveal any information identifying you or the composition or contents of your solid waste to any person except the County, or as required by law.

Thank You for Allowing Ware Disposal Inc. to Serve You!

www.waredisposal.com

Exhibit 17 – Contractor Documentation

Item B.4 - Unpermitted Waste Screening Protocol (Section 13)

This item consists of 2 pages (including this page).

Ware Disposal handles Unpermitted Waste through an Unpermitted Waste Screening Protocol, including our Safe Disposal Education Program (pursuant to Part II, Sample Contract, Section 13). Our plan includes the following.

Ongoing employee training in identification, safety and notification procedures, including leaving non-collection notices, when safe; all drivers are provided rigorous training prior to operating any refuse, recycling and organics collection truck and scout vehicle, and given periodic refresher training in accordance with our employee safety manual

Drivers visually inspect contents during tipping of containers into vehicles, as well as video recording

Where unpermitted wastes are identified as being loaded into the truck, drivers are given instruction to immediately report the issue, whereupon the vehicle is directed to Madison Materials for subsequent load segregation

Drivers are required to provide immediate notification, such as calling dispatch or the active field supervisor

Ware Disposal manager is then required to provide notification of appropriate local agency or department

Appropriate action, such as segregation and containerization for manifesting and transport for disposal in accordance with applicable law or securing services of permitted handling and transport company, is then conducted

Ware Disposal assures compliance with applicable law, including regulations of the United States Department of Transportation (DOT) (Title 49 CFR) and of the United States Environmental Protection Agency (Title 40 CFR)

Where unpermitted wastes are segregated, material is stored in appropriate containers, which are then properly labeled

Exhibit 17 – Contractor Documentation

Item B.5 - Acknowledgment

This item consists of 2 pages (including this page).

CAUTION: External Email. Proceed Responsibly.

I am providing this email as an acknowledgement . Confirmed

Jay Ware

General Manager

PO Box 1318 | Santa Ana, CA 92702

(714) 664-0677 | (714) 664-0696 | jay@wardisposal.com | www.wardisposal.com

Exhibit 17 – Contractor Documentation

Item B.6 - Insurance and Performance Assurance (Part 4 of Exhibit 5 and Section 15)

This item consists of 14 pages (including this page).

Signed and sealed this 19th day of July, 2022.

Principal Ware Disposal, Inc. Surety RLI Insurance Company
BY: [Signature] (Seal) BY: [Signature] (Seal)
Name and Title Attorney-in-fact
BY: [Signature] President
Name and Title

APPROVED AS TO FORM:
DAWYN R. HARRISON
Acting County Counsel
BY: [Signature]
Deputy

SEE ATTACHED CERTIFICATE
DATE 07/19/22 NOTARY INITIALS [Signature]

CALIFORNIA ALL-PURPOSE CERTIFICATE OF ACKNOWLEDGMENT

A notary public or other officer completing this certificate verifies only the identity of the individual who signed the document to which this certificate is attached, and not the truthfulness, accuracy, or validity of that document.

State of California
County of Orange

On August 4, 2022 before me, Kiley Nicole Jahn, Notary Public,
personally appeared Judith Wade,
who proved to me on the basis of satisfactory evidence to be the person(s) whose
name(s) is/are subscribed to the within instrument and acknowledged to me that
he/she/they executed the same in his/her/their authorized capacity(ies), and that by
his/her/their signature(s) on the instrument the person(s), or the entity upon behalf
of which the person(s) acted, executed the instrument.

I certify under PENALTY OF PERJURY under the laws of the State of California
that the foregoing paragraph is true and correct.

WITNESS my hand and official seal.

Signature _____

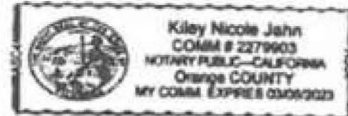

ADDITIONAL INFORMATION (OPTIONAL)

DESCRIPTION OF THE ATTACHED DOCUMENT

(Brief description of attached document)

(Full description of attached document attached)

Number of pages _____ Document Date _____

(Additional information)

NOTARY PUBLIC CONTACT INFORMATION

The UPS Store
21163 Newport Coast Drive
Newport Coast, CA 92657

949-423-2134 tel
949-520-7016 fax

store7336@theupsstore.com
www.TheUPSStore.com/7336

POWER OF ATTORNEY

RLI Insurance Company Contractors Bonding and Insurance Company

9025 N. Lindbergh Dr. Peoria, IL 61615
Phone: 800-645-2402

Know All Men by These Presents:

That this Power of Attorney is not valid or in effect unless attached to the bond which it authorizes executed, but may be detached by the approving officer if desired.

That RLI Insurance Company and/or Contractors Bonding and Insurance Company, each an Illinois corporation, (separately and together, the "Company") do hereby make, constitute and appoint:

Kenneth A. Coate, Julia B. Bales, Matthew S. Costello, Salvador C. Sandoval, Paul W. Lewis, Diane M. Nielsen, Renae N. Balderas,
jointly or severally

in the City of Riverside, State of California its true and lawful Agent(s) and Attorney(s) in Fact, with full power and authority hereby conferred, to sign, execute, acknowledge and deliver for and on its behalf as Surety, in general, any and all bonds and undertakings in an amount not to exceed Twenty Five Million Dollars (\$25,000,000.00) for any single obligation.

The acknowledgment and execution of such bond by the said Attorney in Fact shall be as binding upon the Company as if such bond had been executed and acknowledged by the regularly elected officers of the Company.

RLI Insurance Company and/or Contractors Bonding and Insurance Company, as applicable, have each further certified that the following is a true and exact copy of a Resolution adopted by the Board of Directors of each such corporation, and is now in force, to-wit:

"All bonds, policies, undertakings, Powers of Attorney or other obligations of the corporation shall be executed in the corporate name of the Company by the President, Secretary, any Assistant Secretary, Treasurer, or any Vice President, or by such other officers as the Board of Directors may authorize. The President, any Vice President, Secretary, any Assistant Secretary, or the Treasurer may appoint Attorneys in Fact or Agents who shall have authority to issue bonds, policies or undertakings in the name of the Company. The corporate seal is not necessary for the validity of any bonds, policies, undertakings, Powers of Attorney or other obligations of the corporation. The signature of any such officer and the corporate seal may be printed by facsimile."

IN WITNESS WHEREOF, the RLI Insurance Company and/or Contractors Bonding and Insurance Company, as applicable, have caused these presents to be executed by its respective Vice President with its corporate seal affixed this 10th day of March, 2022.



RLI Insurance Company
Contractors Bonding and Insurance Company
By: Barton W. Davis
Barton W. Davis Vice President

State of Illinois }
County of Peoria } SS

CERTIFICATE

On this 10th day of March, 2022, before me, a Notary Public, personally appeared Barton W. Davis, who being by me duly sworn, acknowledged that he signed the above Power of Attorney as the aforesaid officer of the RLI Insurance Company and/or Contractors Bonding and Insurance Company and acknowledged said instrument to be the voluntary act and deed of said corporation.

I, the undersigned officer of RLI Insurance Company and/or Contractors Bonding and Insurance Company, do hereby certify that the attached Power of Attorney is in full force and effect and is irrevocable; and furthermore, that the Resolution of the Company as set forth in the Power of Attorney, is now in force. In testimony whereof, I have hereunto set my hand and the seal of the RLI Insurance Company and/or Contractors Bonding and Insurance Company this 19th day of July, 2022.

By: Catherine D. Glover
Catherine D. Glover Notary Public

RLI Insurance Company
Contractors Bonding and Insurance Company
By: Jeffrey D. Fick
Jeffrey D. Fick Corporate Secretary

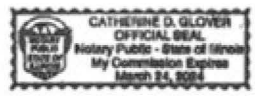

04687202012

A0058D19

CALIFORNIA ACKNOWLEDGMENT

CIVIL CODE § 1189

A notary public or other officer completing this certificate verifies only the identity of the individual who signed the document to which this certificate is attached, and not the truthfulness, accuracy, or validity of that document.

State of California }
County of Riverside }

On JUL 19 2022 before me, Karina J. Cotton, Notary Public
Date Here Insert Name and Title of the Officer

personally appeared Renae N. Balderas
Name(s) of Signer(s)

who proved to me on the basis of satisfactory evidence to be the person(s) whose name(s) is/are subscribed to the within instrument and acknowledged to me that he/she/they executed the same in his/her/their authorized capacity(ies), and that by his/her/their signature(s) on the instrument the person(s), or the entity upon behalf of which the person(s) acted, executed the instrument.

I certify under PENALTY OF PERJURY under the laws of the State of California that the foregoing paragraph is true and correct.

WITNESS my hand and official seal.



Place Notary Seal and/or Stamp Above

Signature [Handwritten Signature]
Signature of Notary Public

OPTIONAL

Completing this information can deter alteration of the document or fraudulent reattachment of this form to an unintended document.

Description of Attached Document
Title or Type of Document: _____
Document Date: _____ Number of Pages: _____
Signer(s) Other Than Named Above: _____

Capacity(ies) Claimed by Signer(s)

| | |
|--|--|
| Signer's Name: _____ | Signer's Name: _____ |
| <input type="checkbox"/> Corporate Officer – Title(s): _____ | <input type="checkbox"/> Corporate Officer – Title(s): _____ |
| <input type="checkbox"/> Partner – <input type="checkbox"/> Limited <input type="checkbox"/> General | <input type="checkbox"/> Partner – <input type="checkbox"/> Limited <input type="checkbox"/> General |
| <input type="checkbox"/> Individual <input type="checkbox"/> Attorney In Fact | <input type="checkbox"/> Individual <input type="checkbox"/> Attorney In Fact |
| <input type="checkbox"/> Trustee <input type="checkbox"/> Guardian or Conservator | <input type="checkbox"/> Trustee <input type="checkbox"/> Guardian or Conservator |
| <input type="checkbox"/> Other: _____ | <input type="checkbox"/> Other: _____ |
| Signer is Representing: _____ | Signer is Representing: _____ |



Inland Surety

A Division of HUB International Insurance Services Inc.
License No. 0757776

3390 University Avenue, Suite 300 • Riverside, CA 92501 • (951)788-8581 • Fax (951)742-4701 • cal.inlandsurety@hubinternational.com

May 20, 2022

Ware Disposal, Inc.
Attention: Jason Rush
1035 East 4th St.
Santa Ana, CA 92701

Cc:

Re: San Gabriel West

- Enclosed is/are ONE (1) ORIGINAL(S) and YOUR COPY of the bond(s).
- As applicable, sign and notarize the ORIGINAL(S).
- File the ORIGINAL(S) directly with the OBLIGEE.
- The ORIGINAL(S) has/have been sent directly to the OBLIGEE.

TRANSACTION: New Other:
BOND TYPE: Renewable 100 % Performance & Payment Bond
BOND DESCRIPTION: San Gabriel West

PRINCIPAL: Ware Disposal, Inc.
OBLIGEE: County of Los Angeles, Dept. of Public Works
 900 S. Fremont Ave
 Alhambra, CA 91803

Dual / Multiple Obligee(s) No Yes

SURETY: RLI Insurance Company

| | | |
|--------------------|--|---------------------|
| BOND NUMBER | EFFECTIVE DATE | RENEWAL DATE |
| CMS0289008 | 09/01/2022 | 08/31/2023 |
| BOND AMOUNT | CONTRACT AMOUNT | |
| \$50,000.00 | \$50,000.00 | |
| PREMIUM: | \$750.00 The premium is predicated on the final contract price and is subject to adjustment. | |
| INVOICE: | <input type="checkbox"/> Included <input checked="" type="checkbox"/> To Follow | |

RENEWAL TERMS:

Please let us know what questions you may have. Your business is very important to us.

THIS ENDORSEMENT CHANGES THE POLICY. PLEASE READ IT CAREFULLY.

**WAIVER OF TRANSFER OF RIGHTS OF RECOVERY
AGAINST OTHERS TO US (WAIVER OF SUBROGATION)**

This endorsement modifies insurance provided under the following:

AUTO DEALERS COVERAGE FORM
BUSINESS AUTO COVERAGE FORM
MOTOR CARRIER COVERAGE FORM

With respect to coverage provided by this endorsement, the provisions of the Coverage Form apply unless modified by the endorsement.

This endorsement changes the policy effective on the inception date of the policy unless another date is indicated below.

| |
|---|
| Named Insured: WARE DISPOSAL, INC. Endorsement Effective Date: February 28, 2022 |
|---|

SCHEDULE

| |
|---|
| Name(s) Of Person(s) Or Organization(s): ANY PERSON OR ORGANIZATION THAT YOU ARE REQUIRED IN A WRITTEN CONTRACT OR WRITTEN AGREEMENT TO WAIVE ANY RIGHT OF RECOVERY WE MAY HAVE AGAINST THE PERSON OR ORGANIZATION, PROVIDED THE "BODILY INJURY" OR "PROPERTY DAMAGE" OCCURS SUBSEQUENT TO THE EXECUTION OF THE WRITTEN CONTRACT OR WRITTEN AGREEMENT. |
|---|

| |
|--|
| Information required to complete this Schedule, if not shown above, will be shown in the Declarations. |
|--|

The Transfer Of Rights Of Recovery Against Others To Us condition does not apply to the person(s) or organization(s) shown in the Schedule, but only to the extent that subrogation is waived prior to the "accident" or the "loss" under a contract with that person or organization.

THIS ENDORSEMENT CHANGES THE POLICY. PLEASE READ IT CAREFULLY.

**ADDITIONAL INSURED – OWNERS, LESSEES OR
CONTRACTORS – SCHEDULED PERSON OR
ORGANIZATION**

This endorsement modifies insurance provided under the following:

COMMERCIAL GENERAL LIABILITY COVERAGE PART

SCHEDULE

| Name Of Additional Insured Person(s) Or Organization(s) | Location(s) Of Covered Operations |
|---|---|
| Any person or organization where required by written contract provided that such contract was executed prior to the date of loss. | All Locations as required per written contract. |
| Information required to complete this Schedule, if not shown above, will be shown in the Declarations. | |

A. Section II – Who Is An Insured is amended to include as an additional insured the person(s) or organization(s) shown in the Schedule, but only with respect to liability for "bodily injury", "property damage" or "personal and advertising injury" caused, in whole or in part, by:

1. Your acts or omissions; or
2. The acts or omissions of those acting on your behalf;

in the performance of your ongoing operations for the additional insured(s) at the location(s) designated above.

However:

1. The insurance afforded to such additional insured only applies to the extent permitted by law; and
2. If coverage provided to the additional insured is required by a contract or agreement, the insurance afforded to such additional insured will not be broader than that which you are required by the contract or agreement to provide for such additional insured.

B. With respect to the insurance afforded to these additional insureds, the following additional exclusions apply:

This insurance does not apply to "bodily injury" or "property damage" occurring after:

1. All work, including materials, parts or equipment furnished in connection with such work, on the project (other than service, maintenance or repairs) to be performed by or on behalf of the additional insured(s) at the location of the covered operations has been completed; or
2. That portion of "your work" out of which the injury or damage arises has been put to its intended use by any person or organization other than another contractor or subcontractor engaged in performing operations for a principal as a part of the same project.

C. With respect to the insurance afforded to these additional insureds, the following is added to **Section III – Limits Of Insurance:**

If coverage provided to the additional insured is required by a contract or agreement, the most we will pay on behalf of the additional insured is the amount of insurance:

1. Required by the contract or agreement; or

2. Available under the applicable limits of insurance;

whichever is less.

This endorsement shall not increase the applicable limits of insurance.

THIS ENDORSEMENT CHANGES THE POLICY. PLEASE READ IT CAREFULLY.

ADDITIONAL INSURED – OWNERS, LESSEES OR CONTRACTORS – COMPLETED OPERATIONS

This endorsement modifies insurance provided under the following:

COMMERCIAL GENERAL LIABILITY COVERAGE PART
PRODUCTS/COMPLETED OPERATIONS LIABILITY COVERAGE PART

SCHEDULE

| Name Of Additional Insured Person(s) Or Organization(s) | Location And Description Of Completed Operations |
|---|--|
| Any person or organization where required by written contract provided that such contract was executed prior to the date of loss. | All Locations as required per written contract. |
| Information required to complete this Schedule, if not shown above, will be shown in the Declarations. | |

A. Section II – Who Is An Insured is amended to include as an additional insured the person(s) or organization(s) shown in the Schedule, but only with respect to liability for "bodily injury" or "property damage" caused, in whole or in part, by "your work" at the location designated and described in the Schedule of this endorsement performed for that additional insured and included in the "products-completed operations hazard".

However:

1. The insurance afforded to such additional insured only applies to the extent permitted by law; and
2. If coverage provided to the additional insured is required by a contract or agreement, the insurance afforded to such additional insured will not be broader than that which you are required by the contract or agreement to provide for such additional insured.

B. With respect to the insurance afforded to these additional insureds, the following is added to Section III – Limits Of Insurance:

If coverage provided to the additional insured is required by a contract or agreement, the most we will pay on behalf of the additional insured is the amount of insurance:

1. Required by the contract or agreement; or
2. Available under the applicable limits of insurance;

whichever is less.

This endorsement shall not increase the applicable limits of insurance.



WAIVER OF OUR RIGHT TO RECOVER FROM OTHERS ENDORSEMENT - CALIFORNIA

We have the right to recover our payments from anyone liable for an injury covered by this policy. We will not enforce our right against the person or organization named in the Schedule. (This agreement applies only to the extent that you perform work under a written contract that requires you to obtain this agreement from us.)

You must maintain payroll records accurately segregating the remuneration of your employees while engaged in the work described in the Schedule.

The additional premium for this endorsement shall be 2% of the California workers' compensation premium otherwise due on such remuneration.

SCHEDULE

| Person or Organization | SCHEDULE | Job Description |
|--|----------|-----------------|
| Blanket Waiver: | | |
| Any person or organization for whom the insured, has agreed by written contract, to furnish this waiver. | | |

This endorsement changes the policy to which it is attached and, unless otherwise stated, is effective on the date issued at 12:01 A.M. standard time at your mailing address shown in the policy. **The information below is required only when this endorsement is issued subsequent to commencement of the policy.**

Endorsement Effective August, 1 2022

Policy No. 22H WS 05460

Insured Ware Disposal, Inc.

Endorsement No. 5

Countersigned By Wayne Bryan

Hub International Insurance Services/
Sacramento CA

WC 04 03 08 (04 84)

ENDORSEMENT #011

This endorsement, effective 12:01 a.m., February 28, 2022 forms a part of Policy No. AEC004538607 issued to WARE DISPOSAL, INC. by Greenwich Insurance Company.

THIS ENDORSEMENT CHANGES THE POLICY. PLEASE READ IT CAREFULLY.

AUTOMATIC ADDITIONAL INSURED

This endorsement modifies insurance provided under the following:

BUSINESS AUTO COVERAGE FORM
MOTOR CARRIER COVERAGE FORM
AUTO DEALERS COVERAGE FORM

A. **COVERED AUTOS LIABILITY COVERAGE, Who Is An Insured**, is amended to include as an "insured" any person or organization you are required in a written contract to name as an additional insured, but only for "bodily injury" or "property damage" otherwise covered under this policy caused, in whole or in part, by the negligent acts or omissions of:

1. You, while using a covered "auto"; or
2. Any other person, except the additional insured or any employee or agent of the additional insured, operating a covered "auto" with your permission;

Provided that:

- a. The written contract is in effect during the policy period of this policy;
- b. The written contract was signed by you and executed prior to the "accident" causing "bodily injury" or "property damage" for which liability coverage is sought; and
- c. Such person or organization is an "insured" solely to the extent required by the contract, but in no event if such person or organization is solely negligent.

B. The Limits of Insurance provided for the Additional Insured shall not be greater than those required by contract and, in no event shall the Limits of Insurance set forth in this policy be increased by the contract.

C. **General Conditions, Other Insurance** is amended as follows:

Any coverage provided hereunder shall be excess over any other valid and collectible insurance available to the additional insured whether such insurance is primary, excess, contingent or on any other basis unless the contract specifically requires that this policy be primary.

All terms, conditions, exclusions and limitations of this policy shall apply to the liability coverage provided to any additional insured, and in no event shall such coverage be enlarged or expanded by reason of the contract.

All other terms and conditions of this policy remain unchanged.

Exhibit 17 – Contractor Documentation

Item B.7 - Internal Revenue Service Notice 1015 (Part 8B1 of Exhibit 5)

This item consists of 2 pages (including this page).

CAUTION: External Email. Proceed Responsibly.

I am providing this email as an acknowledgement. Confirmed

Jay Ware

General Manager

PO Box 1318 | Santa Ana, CA 92702

(714) 664-0677 | (714) 664-0696 | jay@waredisposal.com | www.waredisposal.com



Department of the Treasury Internal Revenue Service

Notice 1015

(Rev. December 2021)

Have You Told Your Employees About the Earned Income Credit (EIC)?

What Is the EIC?

The EIC is a refundable tax credit for certain workers.

Which Employees Must I Notify About the EIC?

You must notify each employee who worked for you at any time during the year and from whose wages you did not withhold income tax. However, you do not have to notify any employee who claimed exemption from withholding on Form W-4, Employee's Withholding Certificate.

Note: You are encouraged to notify each employee whose wages for 2021 are less than \$57,414 that he or she may be eligible for the EIC.

How and When Must I Notify My Employees?

You must give the employee one of the following.

- The IRS Form W-2, Wage and Tax Statement, which has the required information about the EIC on the back of Copy B.
- A substitute Form W-2 with the same EIC information on the back of the employee's copy that is on Copy B of the IRS Form W-2.
- Notice 797, Possible Federal Tax Refund Due to the Earned Income Credit (EIC).
- Your written statement with the same wording as Notice 797.

If you give an employee a Form W-2 on time, no further notice is necessary if the Form W-2 has the required information about the EIC on the back of the employee's copy. If you give an employee a substitute Form W-2, but it does not have the required information, you

must notify the employee within 1 week of the date the substitute Form W-2 is given. If Form W-2 is required but is not given on time, you must give the employee Notice 797 or your written statement by the date Form W-2 is required to be given. If Form W-2 is not required, you must notify the employee by February 7, 2022.

You must hand the notice directly to the employee or send it by first-class mail to the employee's last known address. You will not meet the notification requirements by posting Notice 797 on an employee bulletin board or sending it through office mail. However, you may want to post the notice to help inform all employees of the EIC. You can download copies of the notice at www.irs.gov/FormsPubs. Or you can go to www.irs.gov/OrderForms to order it.

How Will My Employees Know if They Can Claim the EIC?

The basic requirements are covered in Notice 797. For more detailed information, the employee needs to see Pub. 596, Earned Income Credit (EIC), or the Instructions for Forms 1040 and 1040-SR.

How Do My Employees Claim the EIC?

An eligible employee claims the EIC on his or her 2021 tax return. Even an employee who has no tax withheld from wages and owes no tax may claim the EIC and ask for a refund, but he or she must file a tax return to do so. For example, if an employee has no tax withheld in 2021 and owes no tax but is eligible for a credit of \$800, he or she must file a 2021 tax return to get the \$800 refund.

Notice **1015** (Rev. 12-2021)
Cat. No. 205991

Exhibit 17 – Contractor Documentation

Item B.8 - CONTRACTOR's EEO Certification (Part 8D3 of Exhibit 5)

This item consists of 2 pages (including this page).

PROPOSER'S EQUAL EMPLOYMENT OPPORTUNITY CERTIFICATION

| |
|--|
| Proposer's Name WARE DISPOSAL INC. |
| Address 1451 MANHATTAN AVENUE, FULLERTON, CALIFORNIA 92831 5221 |
| Internal Revenue Service Employer Identification Number 95 374 3725 |

In accordance with Los Angeles County Code, Section 4.32.010, the Proposer certifies and agrees that all persons employed by it, its affiliates, subsidiaries, or holding companies are and will be treated equally by the firm without regard to or because of race, religion, ancestry, national origin, or sex and in compliance with all antidiscrimination laws of the United States of America and the State of California.

| | | |
|----|---|--|
| 1. | The proposer has a written policy statement prohibiting any discrimination in all phases of employment. | <input checked="" type="checkbox"/> YES <input type="checkbox"/> NO |
| 2. | The proposer periodically conducts a self-analysis or utilization analysis of its work force. | <input checked="" type="checkbox"/> YES <input type="checkbox"/> NO |
| 3. | The proposer has a system for determining if its employment practices are discriminatory against protected groups. | <input checked="" type="checkbox"/> YES <input type="checkbox"/> NO |
| 4. | Where problem areas are identified in employment practices, the proposer has a system for taking reasonable corrective action to include establishment of goals and timetables. | <input checked="" type="checkbox"/> YES <input type="checkbox"/> NO |

| | |
|---|-----------------------------|
| Proposer WARE DISPOSAL INC. | |
| Authorized representative JUDITH HELAINE WARE | |
| Signature  | Date 1 February 2022 |

Exhibit 17 – Contractor Documentation

Item B.9 - Sharps Collection (Item F1a of Exhibit 3A1)

This item consists of 2 pages (including this page).

Sharps collection, whereby Ware Disposal will provide occupants without charge either pre-paid mailers or sharp containers (up to four items per year).

Exhibit 17 – Contractor Documentation

Item B.10 - Director-Approved Subcontractors

This item consists of 2 pages (including this page).

No subcontractors will be utilized for the San Gabriel Valley West service area, for the term of the contract.

Exhibit 17 – Contractor Documentation

Item B.11- Backup Service Plan (Section 11C)

This item consists of 3 pages (including this page).

Ware Disposal will implement its Backup Service Plan within seven days of Director request if customer's solid waste is not collected at customer's set-out site, including uncontrollable circumstances. Examples of such circumstances include Ware Disposal employees on strike, natural disaster; mudslides, wildfires, or earthquakes that cause blocked or damaged roads. In the event there is a protracted service disruption due to any cause, Ware Disposal will initiate proactive actions to ensure solid waste services are available. Ware Disposal will designate appropriate services below for Director approval at no additional charges to the customer or County during these circumstances, except as noted below.

1. Ware Disposal will provide 3 or 4-yard dumpsters and/or roll-off containers throughout the community in key locations approved by Director.

2. Ware Disposal will make arrangement to offer self-hauling of solid waste facility normally used for this contract for customer direct access and disposal of their solid waste, 6 days per week. The facility shall only charge the customer for disposal costs for quantities exceeding 100 pounds and there shall be no minimum quantities. Additionally, if Director determines the distance to Ware Disposal's usual facility is too far from occupants, Ware Disposal will arrange direct and self-hauling to a local facility for all customers.

3. Ware Disposal will provide customers and occupants with information on where and how to dispose of their solid waste by the following means:

- A recording on its customer service line
- Arrange for the broadcast of the counties 30-second Public Service Announcement video on local cable access channels addressing situation
- Ware Disposal will contact local print media and produce a press release
- Ware Disposal will utilize phone, e-mail, or text messages as notification

4. Ware Disposal will automatically credit customers account for all missed contract services and apply to next quarter's fee. In addition, if Ware Disposal is unable provide such services as Bulky Item Collection, Community Meetings, or other required services, alternate services will be devised and presented for Director approval.

5. Ware Disposal will use reasonable business efforts to require all properly trained and licensed employees to operate collection vehicles to maintain core disposal and diversion services. As described in the above paragraphs, Ware Disposal will staff accordingly to provide drop-off services for each customer and occupant. As deemed necessary Ware Disposal will use drivers or vehicles from other operations and other waste haulers to maintain core services of disposal and diversion. In cases of a strike, Ware Disposal will work closely with a private security firm to guarantee a safe and consistent operation.

6. Ware Disposal will identify customers requiring priority services, elderly and disabled occupants, and shall use reasonable business efforts to collect putrescible solid waste from their residence

Exhibit 17 – Contractor Documentation

Item B.12 - Key Personnel (Section 4J)

This item consists of 2 pages (including this page).



DISPOSAL, INC.

Providing Solid Waste and Recycling Services Since 1968

Management

(714) 664-0677

Staff

| | |
|----------------------------------|--|
| Jay Ware, General Manger | jay@wardisposal.com |
| Jason Rush, Legislative Driector | jason@wardisposal.com |
| Martha Abrea, AVR Manager | marth@wardisposal.com |

LA Dispatch Office

(213) 205-8791

Staff

| | |
|--------------------------------|--|
| Eddie Lara, Operations Manager | eddie@wardisposal.com |
| Juan Lara, Dispatch | juan@wardisposal.com |
| James Campa, Dispatch | james@wardisposal.com |

LA Customer Service

(213) 275-1146

Staff

| | |
|--|--|
| Martin Figueroa, Zero Waste Manager | martin@wardisposal.com |
| Rudy Granados, Zero Waste Specialist | rudy@wardisposal.com |
| Jennifer Figueroa, Zero Waste Specialist | jennifer@wardisposal.com |

Exhibit 17 – Contractor Documentation

Item B.13 - Route Maps

This item consists of 7 pages (including this page).

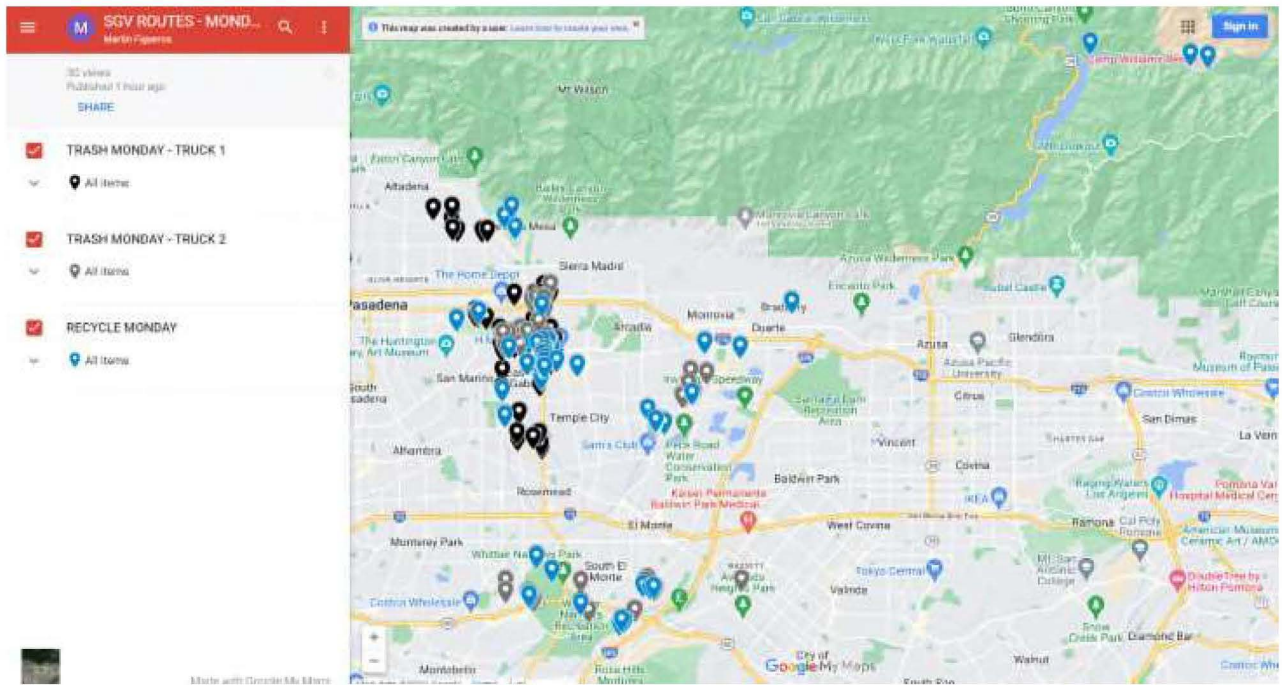

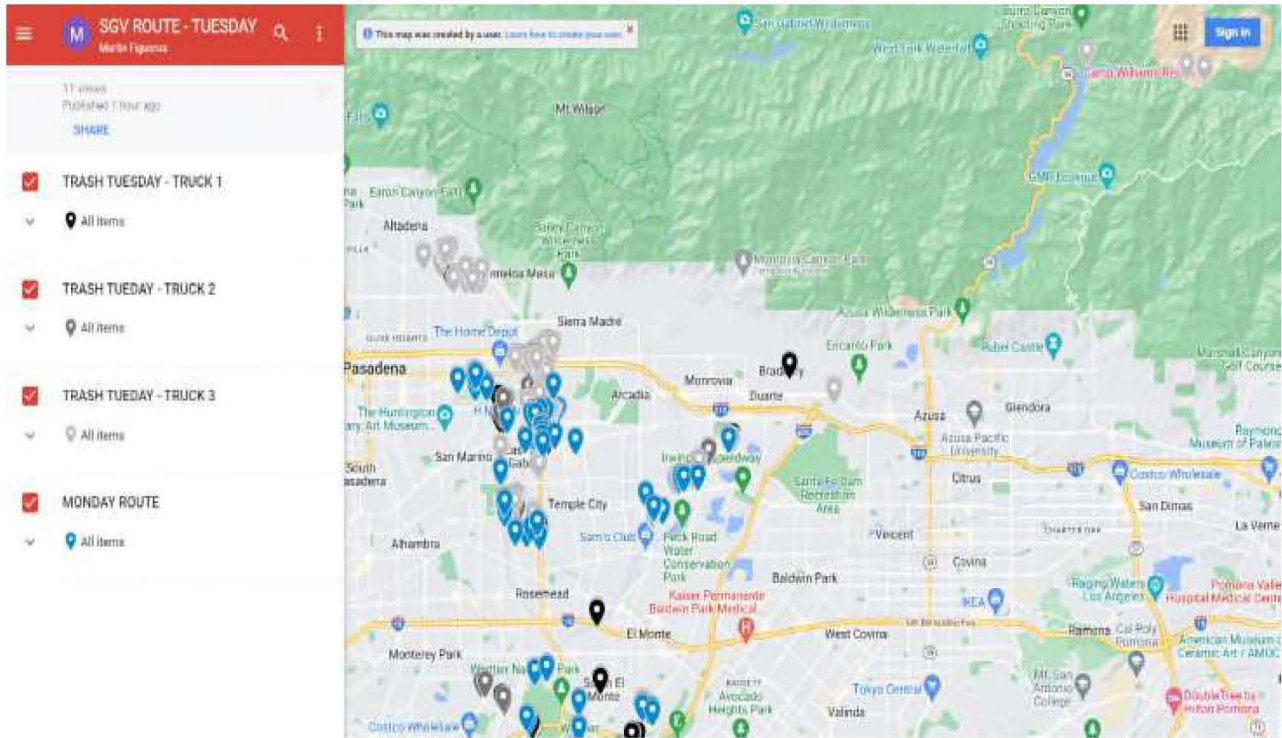

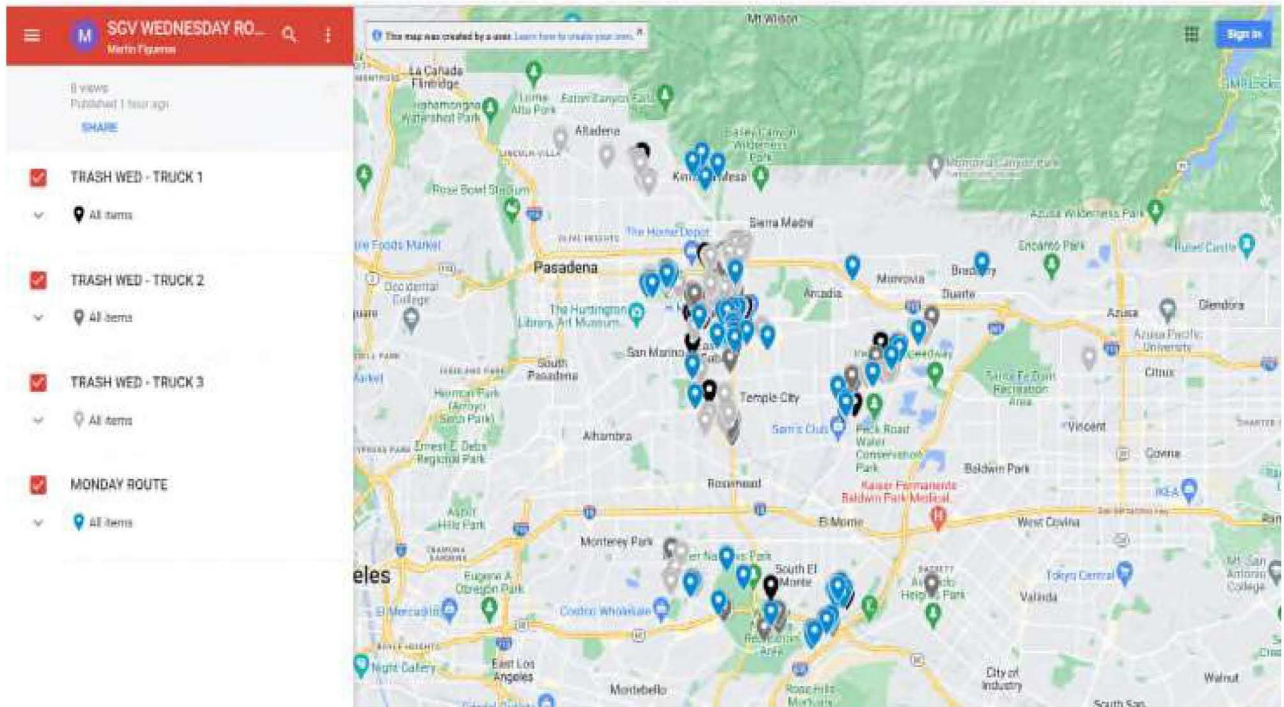

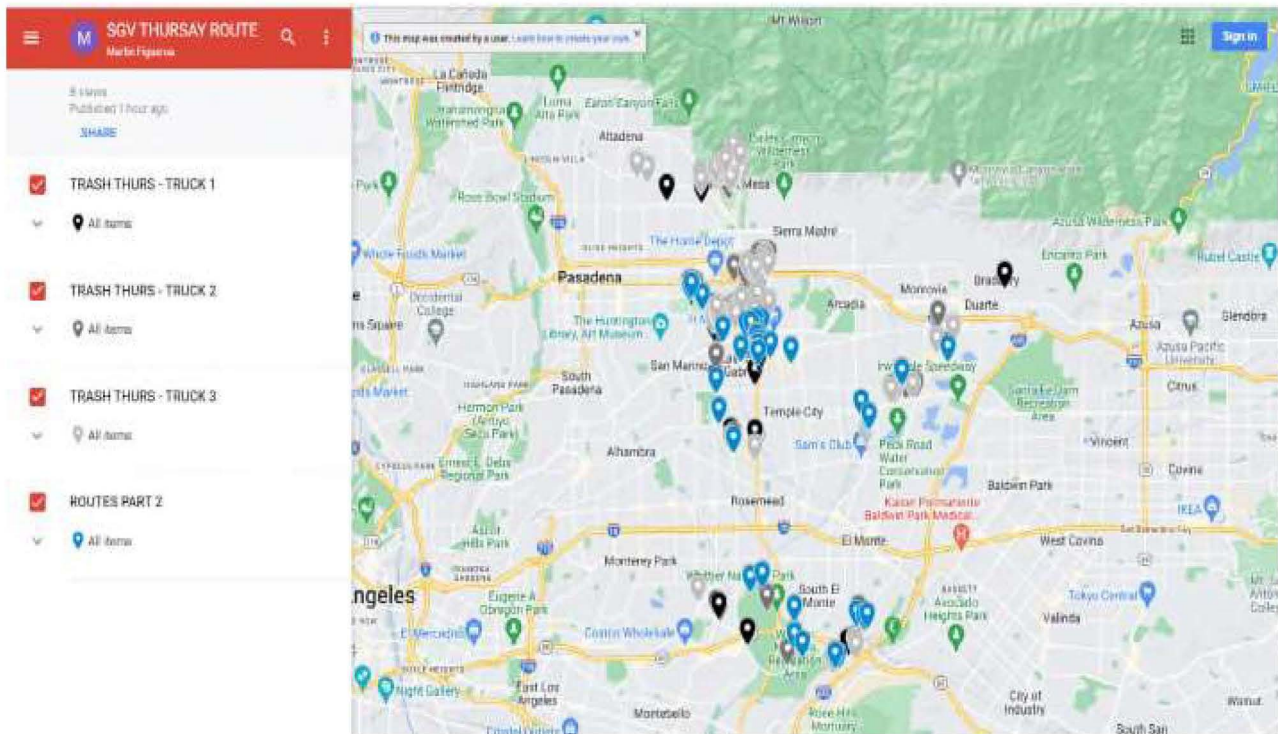

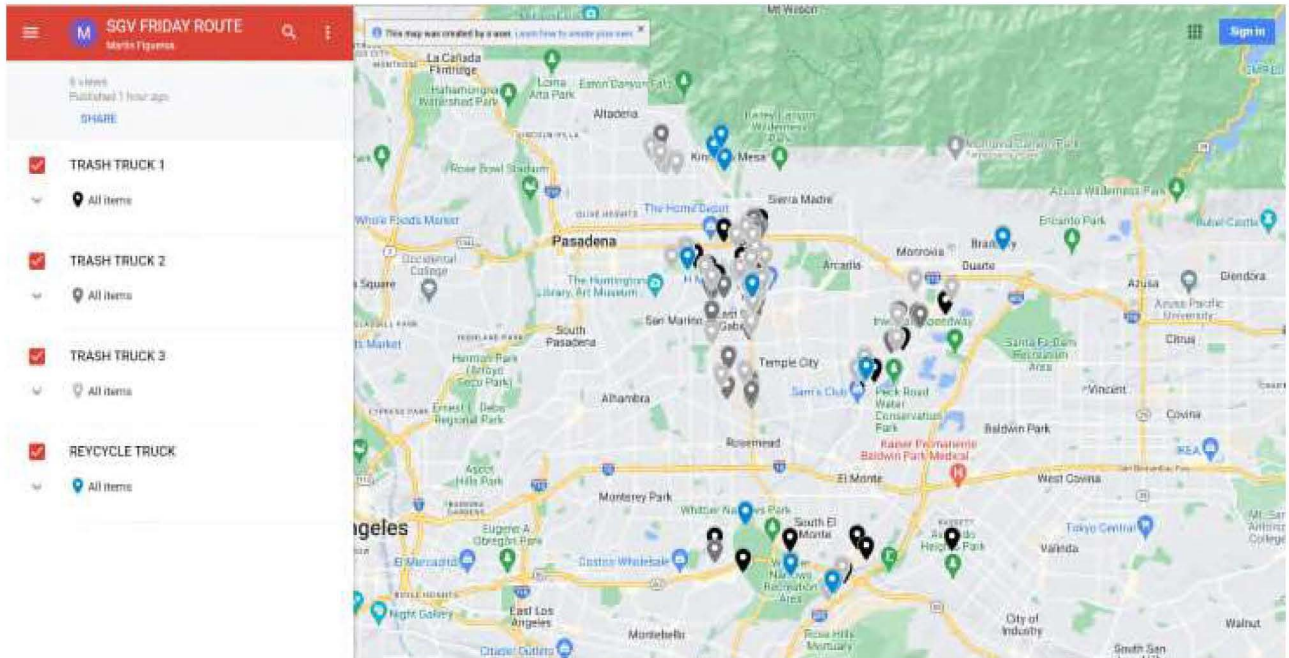

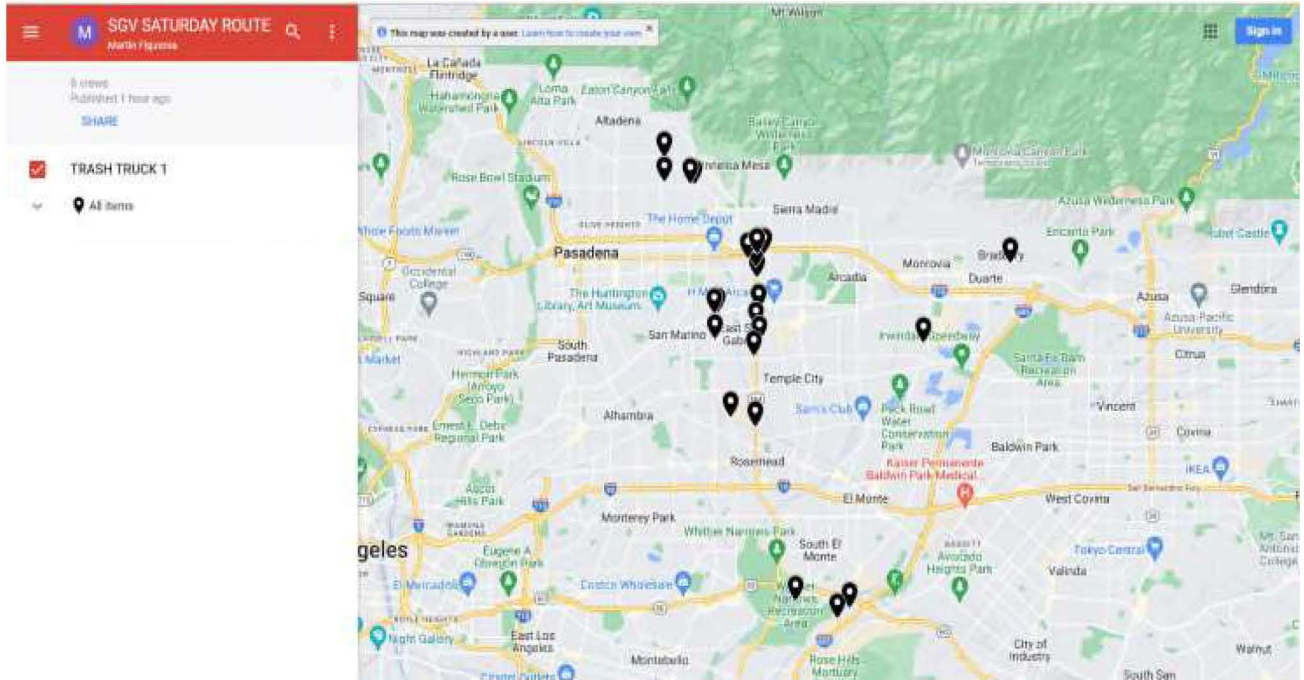

Exhibit 17 – Contractor Documentation

Item B.14 - Collection Schedule (Item A4 of Exhibit 3A1)

This item consists of 3 pages (including this page).

Commercial collection will be scheduled as permitted Monday through Saturday, except following a holiday between the hours of 6 a.m. and 6 p.m. Residential collection will be scheduled as permitted Monday through Friday, except following a holiday.

Ware Disposal will not collect in school zones within 30 minutes of the school's starting time and ending times, or at any time that children are present as well as use reasonable business efforts to adjust the early morning start point of collection routes to address and minimize occupant complaints.

If unable to complete scheduled work within the required hours, Ware Disposal will immediately notify the Director and receive approval to collect outside of regular hours. It is understood that the Director may request a proposal for measures to be taken to maintain the scheduled service without delay or interruption.

Ware Disposal will collect all solid waste on the scheduled collection day(s), at least once per week from customers. the frequency of collection may be reduced at the discretion of Director, but it shall be implemented only if it is permitted by applicable laws. Customers may increase the frequency of their collection for an additional charge to be indicated in the Service Rates Schedule in Attachment 7-2 of Exhibit 7.

For customers that are impacted by street sweeping schedules, any proposed changes in the collection schedule shall have the service day be one to two service days before streets are swept as provided in Director's schedule for street sweeping in the service area (If applicable). Director may amend this collection schedule at any time, and Ware Disposal will use reasonable business efforts to implement this amendment. Ware Disposal will prepare a notice notifying the affected customers and occupants of the change and send such notice to these customers and occupants upon receiving approval from Director

If the Director, a customer, or an occupant notifies Ware Disposal of missed collection, it will arrange for a collection at no additional charge:

No later than 6 p.m. on the day of service, if it receives the complaint by 12 p.m.; or

On the next service day, if the complaint is received after 12 p.m. on the day of service.

Ware Disposal will observe the following Holidays:

New Year's Day

Memorial Day

Independence Day

Labor Day

Thanksgiving Day

Christmas Day

Collection shall be delayed one day for the holiday and the remainder of the holiday week. Waste Disposal may collect on Saturday of the same week for residential customers and occupants and on Sunday for commercial customers and occupants

Exhibit 17 – Contractor Documentation

Item B.15- Solid Waste Collection and Facilities

This item consists of 4 pages (including this page).

The below chart outlines the facilities to be used, including name, location, owner, and operator and phone number along with their associated diversion rate achieved for recyclables, organics (e.g., green waste and organic food waste) and C&D debris.

| Name of Facility | Facility Diversion Rate | Organics Diversion Rate | C&D Debris Diversion Rate | Location |
|--|--------------------------------|--------------------------------|--------------------------------------|---|
| 24th Street Transfer Facility SWIS 19-AR-1251 (323) 262-9699 | 50% | 95% | -- | Owned and operated by Universal Waste Systems 2460 East 24th St, Los Angeles CA 90058 |
| Universal Resource and Recovery SWIS 19-AA-1140 (562) 941-4900 | 50% | 95% | -- | Owned and operated by Universal Waste Systems 9010 Norwalk Blvd., Santa Fe Springs, CA 90670 |
| Puente Hills MRF SWIS 19-AA-1043 (562) 908-4288 | 50% | 95% | -- | Owned and operated by the Sanitation Districts of Los Angeles County; 2808 Workman Mill Rd., Whittier, CA 90601 |
| Madison Materials SWIS 30-AB-0386 (714) 664-0159 | 40% | 95% | 75% | Owned and operated by Madison Materials, Inc.; 1035 E 4th St, Santa Ana, CA 92701 |

Waste Disposal has secured written and/or oral commitments from (1) the Rialto BioEnergy Facility (RBF) – which will provide ample organic waste recycling capacity – and (2) Universal Waste Systems 24th Street Facility for receipt and processing into RBF-required dewatered filter cake. The resultant material will be processed at about 95% recovery which will more than exceed the mandated diversion requirements within the County.

The RBF is a solid waste-permitted organics waste diversion facility (SWIS #36-AA-0446) as defined by SB 1383, and is located at 503 East Santa Ana Avenue Rialto, CA 92376. RBF has committed to accept supplies of pre-processed digestible organic wastes either in diluted (slurry) form or in filter cake (solid) form.

The RBF operates an in-vessel anaerobic digester which can receive and process by permit up to 700 tons per day (tpd) of digestible organic wastes derived from municipal solid waste generators. The facility recycles organics into Renewable Natural Gas (RNG) and digestate suitable for direct land application and for composting into valuable soil amendment with negligible residuals.

Prior to any change in designated facilities, Ware Disposal will provide notification to the Director for approval of change. If a new facility is chosen with a higher fee than the prior facility, Ware Disposal will not increase the Service Rate of its customers or to the county.

Facility Rates

Facility rates are included in the PW-2 and PW-3 Forms.



Date: 6/28/21

Mr. Jay B. Ware
Ware Disposal, Inc.
1035 E 4th St
Santa Ana, CA 92701

Re: Letter of Intent to Accept SB 1383 Defined Organic Wastes at Rialto BioEnergy Facility

Dear Mr. Ware: |

The Rialto BioEnergy Facility (RBF) is a solid waste-permitted organics waste diversion facility (SWIS #36-AA-0446) as defined by SB 1383, and is located at 503 East Santa Ana Avenue Rialto, CA 92376. The RBF operates an in-vessel anaerobic digester which can receive and process by permit up to 1080 tons per day (tpd) of digestible organic wastes derived from municipal solid waste generators. The facility recycles organics into Renewable Natural Gas (RNG) and digestate suitable for direct land application and for composting into valuable soil amendment with negligible residuals.

RBF is interested in securing supplies of pre-processed digestible organic wastes either in diluted (slurry) form or in filter cake (solid) form. All received digestible organics must be delivered by truck from solid waste-permitted transfer and processing facilities authorized to process organic wastes in accordance to SB 1383 regulatory requirements.

RBF is pleased to offer this letter of intent to accept up to 100 tons per day of pre-processed organics for a period not to exceed 10 years.

In addition, RBF is prepared to assist Ware Disposal to acquire our proprietary OREX® pre-processing technology for installation at its facility named Madison Materials Resource Recovery Facility which is a solid waste-permitted facility (SWIS #30-AB-0386) and located at 1035 E. 4th Street, Santa Ana, CA 92701.

This letter does not confer to Ware Disposal an exclusive right to facility capacity at RBF, nor does it commit Ware Disposal to put-or-pay terms in the event of delivery of insufficient weight of materials. Standard terms of contract will apply prior to actual delivery of organic wastes. RBF reserves the right to inspect the pre-processed materials at any time, and the right to reject any load at the supplier's own liability for failure to meet acceptable material and specification requirements as listed above.

If there are any questions, please contact me at yaniv.scherson@anaergia.com.

Yaniv D. Scherson, Ph.D., PE

Chief Operating Officer

Yaniv.Scherson@anaergia.com

705 Palomar Airport Rd, Ste 200, Carlsbad, CA, 92011

Exhibit 17 – Contractor Documentation

Item B.16- Additional CONTRACTOR Commitments

This item consists of 2 pages (including this page).

Ware Disposal will fully and timely satisfy any additional performance obligations as stated in proposal document, to the Director for procurement of this contract.

Exhibit 17 – Contractor Documentation

Item B.17 - Transition Roll-Out Plan (item H of Exhibit 3A1)

This item consists of 3 pages (including this page).

At least 45 days prior to the execution date, Ware Disposal will submit for approval to Director a final 'start-up transition and container roll-out plan' - including both time line and tasks. Ware Disposal will submit its final plan in accordance with item B19 of Exhibit 17, outlining details and roll-out of the Work Plan as identified in the RFP and summarized below.

| Milestone Date | Suggested Activity (Pending County Approval) |
|--|---|
| February 1, 2022 | Proposals due |
| Completed | Award by County |
| Completed | Contract Negotiation |
| August 15, 2022 <i>estimated</i> | Contract Approval; Execution |
| By August 20, 2022 <i>estimated</i> | Conduct transition meeting with current service provider to acquire existing bins and carts, and arrange for smooth transition of service; Acquire route and account information (all routes will be kept as is for at least 180 days after service startup to assure no change is experienced by accounts); Additional trucks and containers ordered; Initiate outreach activities including planning for Town Hall meetings; and Publicize Town Hall Meetings |

| | |
|-----------------------|---|
| By September 15, 2022 | Conduct all site visits and waste assessments; Conduct Town Hall Meetings |
| By September 20, 2022 | Receive trucks and containers |
| By October 1, 2022 | Deliver outreach and education packets to all customers; Mail postcard and letter(s) to inform customers; complete initial analysis of routing requirements and special conditions |
| As warranted | Additional equipment received; initiate staging of additional equipment |
| By October 1, 2022 | Conduct roll out; distribution of additional bins and carts to customers; otherwise, existing bins and carts will be used; Will begin a process of upgrade and replacement to occur over 180 days |
| October 1, 2022 | Start of Service |
| October 1, 2022 | AB 287, AB 341, AB 1826 and SB 1383 programs As agreed upon with County |
| Within 30 days | Initial Transition Report |
| Within 60 days | Complete Transition Report |
| Monthly Reports | Within 15 days of end of preceding month |
| Quarterly Reports | Within 15 days of end of preceding quarter |
| Annual Reports | Within 20 days of end of preceding year |

Exhibit 17 – Contractor Documentation

Item B.18 - Difficult to Service Occupants (Item L of Exhibit 3A1)

This item consists of 2 pages (including this page).

Waste Disposal will provide customers with alternatives to container sizes for premises with space restrictions (Part II, Sample Contract, Exhibit 3A1, Item D.8) and service for difficult-to service premises (Part II, Sample Contract, Exhibit 3A1, Item O). We have specified all containers to be used previously, and the appropriate type will be provided the customer. Difficult to service areas will be identified during the site visits prior to startup of operations.

Exhibit 17 – Contractor Documentation

Item B.19 - Alternative Container Sizes (Item C14 of Exhibit 3A1)

This item consists of 2 pages (including this page).

Waste Disposal will provide customers with alternatives to container sizes for premises with space restrictions (Part II, Sample Contract, Exhibit 3A1, Item D.8) and service for difficult-to service premises (Part II, Sample Contract, Exhibit 3A1, Item O). We have specified all containers to be used previously, and the appropriate type will be provided to the customer. Difficult to service areas will be identified during the site visits prior to startup of operations.

Below is a summary of all containers to be used, a suitable type of container will be provided to all customers.

Summary of containers

| Service Area | Carts for SFRs, MFRs, & Commercial Premises | Containers SFRs, MFRs, & Commercial Premises |
|-------------------------|--|--|
| San Gabriel Valley West | See Attachment F | See Attachment F |
| Wastestreams | Refuse (all sizes, black color) Recycling (all sizes, blue color) Green Waste (all sizes, if needed, green) Manure (65-gallon cart & 2 cys bin) Food Waste Cart (65-gallon only) | Refuse (all sizes, black color) Recycling (all sizes, blue color) Green Waste (all sizes, if needed, green) Manure (65-gallon cart & 2 cys bin) Food Waste Cart (65-gallon only) |
| Carts | Medium density polyethylene (MDPE) using a stress-free rotational molding process <ul style="list-style-type: none"> • 32-gallon (70-pound maximum load capacity); • 64-gallon (130-pound maximum load capacity); and, • 96-gallon (200-pound maximum load capacity). | |
| Bins | N/A | Steel Construction, 1 - 9 cys |
| Recycled Content | 50% - Carts | 80% Steel bins |
| Warranties | Available upon request | Available upon request |
| Age | New/like-new | New/like-new |
| Amortization | 8 to 10 years | 8 to 10 years |
| SB 1383 Compliant | Comply with SB 1383 requirements for purpose, color, identification and labeling | Comply with SB 1383 requirements for purpose, color, identification and labeling |
| Labels | An adhesive label will be affixed to the underside of the lid of each cart indicating the primary materials accepted and the primary materials prohibited for each container | An adhesive label will be affixed to the front of the container indicating the primary materials accepted and the primary materials prohibited for each container |

Exhibit 17 – Contractor Documentation

Item B.20 - Movement of Green Waste

This item consists of 13 pages (including this page).

Ware Disposal complies with all applicable laws regarding transportation of Green Waste, including the California Department of Food and Agriculture's (CDFA's) regulations that quarantine certain types of Green Waste and restrict its movement.

Ware Disposal processes all green waste into either compost or for anerobic digestion. Ware Disposal's organic waste collection services and infrastructure will produce clean streams of organic feedstock that can be recycled into high-quality, marketable recycled products, including compost, mulch or renewable natural gas.

Ware Disposal will educate all residents and businesses about collection requirements, including what materials to put in curbside bins. Education to residents and businesses may vary by jurisdiction and educational content will be provided either electronically, through hard copy materials, or through direct outreach.

Form #1 - Registration Form

| For Official Use Only (County Reviewer) | |
|---|--|
| Name of Reviewer | |
| Reviewer Signature | |
| Date Entered | |
| Registration Number | |

| Application Type | | Operation Type | |
|--|------------------------|---|------------------------|
| <input type="checkbox"/> Renewal <input checked="" type="checkbox"/> New Registration <input type="checkbox"/> Amendment | | <input type="checkbox"/> Producer <input checked="" type="checkbox"/> Handler <input type="checkbox"/> Processor | |
| Company Information | | Company Mailing Address | |
| Company Name: WARE DISPOSAL, INC | | Address: PO BOX 1318 | |
| Phone: 7146640677 | Fax: 7146640696 | Address Cont.: | |
| Principal County of Operation: ORANGE AND LOS ANGELES | | City: SANTA ANA | State: CA |
| | | Zip/Postal Code: 92702 | Country: USA |
| How would you prefer to renew your annual registration: <input type="checkbox"/> Online <input checked="" type="checkbox"/> Mail (2-3 week processing time) | | | |
| Company Physical Address | | Owner Information | |
| Physical address same as mailing address: <input type="checkbox"/> Yes <input checked="" type="checkbox"/> No | | Owner's address same as mailing address: <input checked="" type="checkbox"/> Yes <input type="checkbox"/> No | |
| Address: 1035 E 4TH STREET | | Name: | |
| Address Cont.: | | Company Name: | |
| City: SANTA ANA | State: CA | Owner Address: | |
| Zip/Postal Code: 92701 | Country: USA | Owner Address Cont.: | |
| Is the owner a U.S. Veteran: <input type="checkbox"/> Yes <input checked="" type="checkbox"/> No If yes, a copy of a DD214 is required and must be attached. | | City: | |
| Is the owner also the Primary Contact: <input checked="" type="checkbox"/> Yes <input type="checkbox"/> No | | State: | |
| Owner's preferred method of contact: EMAIL | | Zip/Postal Code: | Country: |
| | | Owner's Email: JAY@WAREDISPOSAL.COM | Phone: |
| Primary Contact | | Additional Contact | |
| Same as mailing address: <input checked="" type="checkbox"/> Yes <input type="checkbox"/> No | | Same as mailing address: <input checked="" type="checkbox"/> Yes <input type="checkbox"/> No | |
| Name: | | Name: | |
| Address: | | Address: | |
| Address Cont.: | | Address Cont.: | |
| City: | State: | City: | State: |
| Zip/Postal Code: | Country: | Zip/Postal Code: | Country: |
| Email: | Phone: | Email: | Phone: |
| Preferred method of contact: <input checked="" type="checkbox"/> Email <input type="checkbox"/> Mail <input type="checkbox"/> Phone | | Preferred method of contact: <input checked="" type="checkbox"/> Email <input type="checkbox"/> Mail <input type="checkbox"/> Phone | |
| Read and sign below | | | |
| I certify that the information associated with this registration is true and correct, to the best of my knowledge, and I agree to abide by the California Organic Food and Farming Act and the National Organic Program regulations. | | | |
|  | | JAY WARE | GENERAL MANAGER |
| | | Date | 07, 14, 22 |
| Registrant Signature | Print Name | Title | month day year |

Instructions for Form #1 – Registration Form

A completed registration packet and payment must be submitted directly to CDFA for review and initial approval.
Make all checks payable to: CDFA Cashier.

For Official Use Only (State Reviewer)

Leave this area blank. This box is designated for CDFA staff.

Application Type

Please indicate the type/purpose of the application you are submitting.

Renewal – Check this box if you are submitting this application to renew an existing organic registration.

New Registration – Check this box if you are new to the organic industry.

Amendment – Check this box if you are adding a site/facility, adding acreage, or changing/adding an operation type to your existing organic registration.

Operation Type [Mark the box(es) that describe your organic operation.]

Producer - the entity that engages in the business of growing or producing organic food, including livestock, feed, or fiber.

Handler - any person or entity that packs, repacks, labels, sorts, stores or otherwise handles organic products, including any organic product that is outside the jurisdiction of the California Department of Public Health.

Processor - CDFA registers processed dairy products and minimally processed meats sold in an unfrozen state, including cut, wrapped, and unseasoned only. Also, processors not required to register with the California Department of Public Health must register with the California Department of Food and Agriculture.

Company Information (Complete all of the requested information)

Company Name and Mailing Address- Provide the company name and mailing address.

Note: If you are certified, the "Company Name" listed must match the company name listed on your organic certification.

Principal County of Operation – The county in California in which the majority of your operation's production, business, or sales take place.

Company Physical Address - Fill out all the requested information if different from the company mailing address.

[the actual physical address of the company office or facility (cannot be a PO Box)]

Owner Information- Information regarding person who owns the operation.

["Company Name"- Complete if operation is owned by another company.]

Veterans Exemption- The state of California allows an exemption for Military Veterans from paying certain fees associated with doing business in this state. If you are an honorably discharged veteran you may elect to choose the exemption. If you choose not to select the exemption then you will be required to pay all applicable fees.

Primary Contact and Additional Contacts- Please indicate who you would like to be your primary contact and provide additional contacts if applicable.

Read and Sign

By signing you certify that the information associated with the application for registration is true and correct, to the best of your knowledge and you agree to abide by the California Organic Food and Farming Act and the National Organic Program regulation.



California Department of Food and Agriculture State Organic Program
Instructions for New or Amended Organic Registrations

APPLICANT'S RESPONSIBILITY

All new and amended registrations may also be completed online at: <https://organic.cdfa.ca.gov/>

It is the applicant's responsibility to provide the most current complete information about your organic operation. It is the registrant's responsibility to ensure current and accurate information is on file with the State Organic Program at all times and the CDFA is not responsible for any extra fees paid due to incorrect information provided by the applicant.

Failure to complete the application accurately and completely may result in the application being returned for proper completion, thus delaying the validation of your registration.

California's State Organic Program consists of two departments; the California Department of Food and Agriculture and the California Department of Public Health.

Who must register with the California Department of Food and Agriculture?

Section 46013.1. (a) California Food and Agriculture Code *Every person engaged in this state in the production or handling of raw agricultural products sold as organic shall register with the secretary before the first sale of the product. All processors of organic agriculturally derived products that are not required to be registered as outlined in subdivision (b) (see below) shall register with the secretary. Each registrant shall annually renew the registration with the secretary unless no longer engaged in the activities requiring the registration.*

Organic Producers - Agricultural Production is defined as the entity that engages in the business of growing or producing organic food, feed, or fiber.

Organic Handlers - A Handler is defined as any person or entity that packs, repacks, labels, sorts, or otherwise handles any organic product that is outside the jurisdiction of the California Department of Public Health.

Organic Processors - CDFA registers all dairy products and minimally processed meats sold in an unfrozen state, including cut, wrapped, and unseasoned only. Also, any processor not covered by the California Department of Public Health shall register with the California Department of Food and Agriculture.

Who must register with the California Department of Public Health?

Section 46013.1. (b) California Food and Agriculture Code *Every person engaged in this state in the processing or handling of processed products pursuant to Section 110460 of the Health and Safety Code, and pet food pursuant to Section 18653, and cosmetics pursuant to Section 111795 of the Health and Safety Code, including processors of alcoholic beverages, shall register with the California Department of Public Health.*

Note: Processing is defined as: Cooking, baking, curing, heating, drying, mixing, grinding, churning, separating, extracting, slaughtering, cutting, fermenting, distilling, eviscerating, preserving, dehydrating, freezing, chilling, or otherwise manufacturing and includes the packaging, canning, jarring, or otherwise enclosing food in a container. If your operation fits any of these descriptions you must register with California Department of Public Health.

What changes to my registration require an "Amendment"?

An Amendment is required when an operation has one or more of the following changes to their registration: Addition of new facilities or growing locations, change of ownership, addition of production acreage, or a change/addition of operation type(s). In addition, Title 3, California Code of Regulations §1391.4 mandates that, "A registrant shall notify the Department of any change in the information reported on the registration form within 14 days or prior to the sale of additional product, and shall pay any additional fee owed if that change results in a higher fee owed than previously paid.

Registering or Amending a Registration with the CDFA State Organic Program

1. Complete required forms #1 –3 (Registration Form; Certification, Site, and Sales Form; & Commodity and Acreage Form)
2. Determine appropriate registration fee (See Fee Chart)
3. If payment by check, make payable to CASHIER-CDFA Organic Program, 41110
4. Submit completed forms along with the appropriate registration fee (if applicable) directly to CDFA.

Applications with payment attached:

CDFA-Organic Program
PO Box 942872
Sacramento, CA 94271-2872

Applications without payment attached:

CDFA-Organic Program
1220 N Street
Sacramento, CA 95814

Upon receipt, CDFA will review the submitted registration and shall validate the registration providing it is complete and in compliance with the State law. Upon validation, CDFA will mail an official valid registration to the registrant.



**California Department of Food and Agriculture State Organic Program
 Organic Fee Determination & Gross Sales Fee Chart**

A registration form shall be accompanied by payment of a **non-refundable** registration fee by all entities engaged in organic activities. Registration fees are based on several factors, see below for exceptions and clarification.

Fee Chart Based on Organic Gross Sales in California

| Annual Gross Sales (California) | Registration Fee |
|---------------------------------|------------------|
| \$ 0 – 4,999 | \$ 25 |
| \$ 5,000 – 10,000 | \$ 50 |
| \$ 10,001 – 50,000 | \$ 75 |
| \$ 50,001 – 250,000 | \$ 100 |
| \$ 250,001 – 500,000 | \$ 450 |
| \$ 500,001 – 1,000,000 | \$ 750 |
| \$ 1,000,001 – 2,500,000 | \$ 1,000 |
| \$ 2,500,001 – 5,000,001 | \$ 1,500 |
| \$ 5,000,001 – 15,000,000 | \$ 2,000 |
| \$ 15,000,001 – 25,000,000 | \$ 2,500 |
| \$ 25,000,001 and above | \$ 3,000 |

Handwritten note: \$25

Any person/entity required to register with CDFA's Organic Program who has multiple operation types must calculate the renewal fee for each separate operation type and then pay the greater of the registration fee amounts. U.S. Veterans: If the owner of the operation is a U.S. Veteran you are exempt from paying registration fees. A copy of your DD214 is required and must be attached.

- PRODUCERS** - The agricultural production renewal fee is based on gross sales of the organic product(s). Any person/entity that hires any other person/entity for custom packing or labeling shall pay a fee based on the total sales of product custom packed for them. **Special Circumstances:** Operations that produce and process only their own product shall pay fees based on the value of the raw product prior to being processed, and the value of any product sold as unprocessed (Examples: Produces olives for olive oil or grapes for wine).
- HANDLERS (DO NOT TAKE POSSESSION/OWNERSHIP)** - Any person/entity that packs, repacks, labels, sorts, or otherwise handles any organic product that is outside the jurisdiction of the State Director of the California Department of Public Health and does not take title or manage the sale of the product, but provides only handling services for the organic product, shall register and pay one hundred dollars (\$100) per year.
- HANDLERS (TAKES POSSESSION/OWNERSHIP)** - Any person/entity that packs, repacks, labels, sorts, or otherwise handles any organic product that is outside the jurisdiction of the State Director of the California Department of Public Health and does take title or manage the sale of the product shall register and pay a fee based on annual gross sales.
- PROCESSORS (DO NOT TAKE POSSESSION/OWNERSHIP)** - Any person/entity that processes any organic product that is outside the jurisdiction of the State Director of the California Department of Public Health and does not take possession/ownership, but provides only processing services for the organic product, shall register and pay one hundred dollars (\$100) per year.
- PROCESSORS - (TAKE POSSESSION/OWNERSHIP)** - Any person/entity that processes any organic product that is outside the jurisdiction of the State Director of the California Department of Public Health and does take possession/ownership shall register and pay a fee based on annual gross sales.



COOPERATIVE ASIAN CITRUS PSYLLID AND HUANGLONGBING QUARANTINE PROGRAM COMPLIANCE AGREEMENT

Orange County Agricultural Commissioner / CDFA / USDA

[Pursuant to California Food and Agriculture Codes 5701-5705, California Code of Regulations 3435, 3439, and 3154, and the Federal Domestic Quarantine Order: Citrus Greening Disease and Asian Citrus Psyllid] and Master Permits QC1386, QC1464, and QC1480

Orange County Agricultural Commissioner's Office
Street Address: 222 E Bristol Lane
Orange, CA 92865
Phone: (714) 955-0100
Fax: (714) 921-2713
Contact: Rebekah Ban

Compliance Agreement Number: 30-CITRUS-0021

| | | | | | |
|-----------------------|---------------------------------|-----------|------------------------|------|------------|
| Establishment Name: | WARE DISPOSAL INC. | | | | |
| Owner / Manager Name: | JAY WARE | | | | |
| Mailing Address: | PO BOX 1318 | City: | SANTA ANA | Zip: | 92702 1318 |
| Physical Address: | 1451 MANHATTAN AVENUE | City: | FULLERTON | Zip: | 92831 8221 |
| Phone: | (714) 664 - 0677 | E-Mail: | jason@waredisposal.com | | |
| Cross Street: | Manhattan and Burton, Fullerton | Lat/Long: | 33.856118, -117.902839 | | |

Program:
The Orange County Agricultural Commissioner, the California Department of Food and Agriculture (CDFA), and the United States Department of Agriculture (USDA), cooperating as the **Asian Citrus Psyllid and Huanglongbing Disease Quarantine Program**.

Business/Establishment:
Establishment Name (subsequently referred to as "Establishment"):
WARE DISPOSAL INC.

Background:
The pests known as Asian citrus psyllid (ACP) and Huanglongbing (HLB) present a real and ongoing threat to the agricultural industry, environment and economy of the State of California. Movement of regulated articles and commodities is a recognized channel for the spread of ACP and HLB from established areas to new locations. The ACP and HLB Quarantine Program is a cooperative effort between public entities that are responsible for mitigating the movement of ACP from regulated areas where the pest is established to new locations. The list of regulated articles and commodities can be found here: <http://phpps.cdfa.ca.gov/PE/InteriorExclusion/pdf/acpexhibitr.pdf>

AGREEMENT:

A. The Asian Citrus Psyllid and Huanglongbing Quarantine Program, hereafter referred to as the Program, will permit your establishment to self-execute the Asian Citrus Psyllid and Huanglongbing quarantine requirements attached as exhibits checked below, inclusive and incorporated into this agreement by reference as if fully set out. The exhibits checked below are binding:

Check all that apply:

| | | |
|-------------------------------------|-----------------------|---|
| <input type="checkbox"/> | Exhibit ACP Citrus-G | Grower / Grove Manager |
| <input type="checkbox"/> | Exhibit ACP Citrus-PH | Citrus Packer / Citrus Juicer/ Citrus Processor |
| <input checked="" type="checkbox"/> | Exhibit ACP Citrus-T | Transporter / Hauler – Citrus Fruit |
| <input type="checkbox"/> | Exhibit 1386-G | Grower / Grove Manager – Mandarins with Stems and Leaves |
| <input type="checkbox"/> | Exhibit 1386-PH | Packer / Processor – Mandarins with Stems and Leaves |
| <input checked="" type="checkbox"/> | Exhibit 1386-T | Transporter / Hauler – Mandarins with Stems and Leaves |
| <input type="checkbox"/> | Exhibit 1480-G | Grower / Grove Manager in an HLB Quarantine Area |
| <input type="checkbox"/> | Exhibit 1480-PH | Packer / Processor – Citrus Fruit Grown in an HLB Quarantine Area |
| <input type="checkbox"/> | Exhibit X1 | Program Management Practices for Aerial Spray Treatments |
| <input type="checkbox"/> | Exhibit X2 | Program Management Practices for Ground Spray and Drench Treatments |
| <input type="checkbox"/> | Exhibit X3 | Program Management Practices for Hazardous Materials Spills |

B. In exchange for the Program's promise contained in sub-paragraph "A" above, the Establishment agrees to abide by the following rules and regulations:

1. Handle, process, and/or move regulated articles in accordance with the Asian Citrus Psyllid and Huanglongbing quarantine requirements;
2. Follow the Program's instructions regarding the use of all permits and certificates;
3. Maintain and make such records, as the Program requires, accessible for inspection upon reasonable notice by the Program Officer. These records shall be maintained for a period of the later of 2 years or the resolution of any outstanding claims.

C. This agreement becomes effective on signing and shall remain in effect until canceled by either party on 30 days notice to the other at the address of either appearing above. However, the Program may accelerate the notice to immediate for cause, including but not limited to the Establishment's abandonment of the procedures outlined in the attached Exhibit(s).

D. Establishment assumes liability, if any, arising from the manner in which Establishment sells, handles or distributes any regulated host material.

NOTICE: Any signatory or employee of any signatory who violates the terms of this Compliance Agreement may be subject to civil penalties pursuant to California Food and Agricultural Code Section 5705.

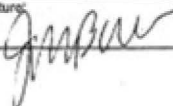
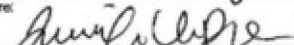
| | |
|---|---|
| Signed in the County of <u>Orange</u> in the State of California on <u>02</u> / <u>27</u> / <u>2018</u> | |
| Establishment Manager/Owner | Program Officer |
| Print Name: JAY WARE | Print Name: Jennifer VanDyke |
| Signature:  | Signature:  |

**EXHIBIT: ACP CITRUS – T
TRANSPORTER / HAULER**

**PROVISIONS FOR THE INTRASTATE MOVEMENT OF BULK CITRUS FRUIT
FROM OR WITHIN AN ASIAN CITRUS PSYLLID BULK CITRUS REGIONAL QUARANTINE ZONE**

To Be Used in Conjunction with QC Permit 1464

Establishment agrees to the following:

1. Establishments Under Compliance

- a. Only transport shipments from a Grower/Grove Manager operating under compliance with the ACP Program.
- b. Only transport shipments to a Packer/Juicer/Other Processor operating under compliance with the Program.

Establishments operating under compliance can be verified online at:

https://www.cdffa.ca.gov/plant/acp/req_establishments.html

2. Safeguarding

All shipments of citrus fruit shall be safeguarded the entire time while in transit, beginning before the vehicle departs the loading site and until it reaches final destination for offloading. Any screen mesh used as an ACP-proof barrier shall be 0.3 square millimeters (e.g. 0.547 x 0.547, or 0.5 x 0.6) or less in size. Approved safeguarding measures include the following:

- a. Citrus fruit is transported in a fully enclosed vehicle, or
- b. Transporting vehicles which have solid wall construction on sides and rear; a solid tarpaulin or ACP-proof barrier shall cover the top. The tarp or ACP-proof barriers shall be in good repair without tears or holes and be securely fastened to the solid walls of the truck, ensuring no gaps are present and in a manner that would prevent exposure to ACP or the loss of fruit, leaves, stems, branches, and plant debris while in transit, or
- c. Transporting vehicles constructed of wire mesh or expanded metal shall be completely covered with a solid tarp or ACP-proof barriers that extend down to the truck bed, ensuring no gaps are present. The tarp or ACP-proof barrier shall be in good repair without tears or holes and be securely fastened to the bed of the truck in a manner that would prevent exposure to ACP or the loss of fruit, leaves, stems, branches, and plant debris while in transit, or
- d. Transporting vehicles which have a flatbed trailer with field pallets or bins shall be entirely covered to the bed of the truck with a solid tarp or ACP-proof barrier. The tarp or screen mesh shall be in good repair without tears or holes and be securely fastened to the bed of the truck, ensuring no gaps are present around the bins, and in a manner that would prevent exposure to ACP or the loss of fruit, leaves, stems, branches, and plant debris while in transit, or
- e. Any other Program approved manner specified in the "Special Instructions."

3. Transporter Cleanliness

The vehicle and/or trailer used for transporting the shipment must be free of all leaf and stem debris and free of all life stages of ACP prior to transport and after delivery.

4. Evidence of Compliance

Place a copy of the compliance agreement, this exhibit, and the applicable "ACP-Free Declaration" form in each transport vehicle.

5. Direct Route

Take the most continuous, direct route, without interruption to a Program approved receiver.

6. Green Waste Disposal

All green waste, including leaf and stem debris, must be continuously collected, safeguarded, and disposed of in accordance with the Program, local County Agricultural Commissioner, under QC Master Permit 1289 or other Program approved manner.

7. Records

Maintain records of all ACP host shipments for a minimum of two years and make such records available to Program officials immediately upon request.

8. Training

Ensure all employees receive training to be compliant with all specifications of the compliance agreement and this exhibit.

9. Spill Notification

Notify the Program as soon as possible and no later than 24 hours after spillage of any shipment.

10. Vehicle Tracking System

List all truck and trailer license plates below. The Establishment shall update the Program immediately any time license plates are added, changed, or are no longer in use. If more space is needed, continue on back of this exhibit or attach pages as needed.

11. Violation

Violation of any terms of the compliance agreement or this exhibit shall result in the suspension of the compliance agreement until an investigation is completed and for a minimum period of two weeks.

Transporter License Plates

Will be provided once vehicles have been procured.

| | | | |
|----|--|----|--|
| 1 | | 11 | |
| 2 | | 12 | |
| 3 | | 13 | |
| 4 | | 14 | |
| 5 | | 15 | |
| 6 | | 16 | |
| 7 | | 17 | |
| 8 | | 18 | |
| 9 | | 19 | |
| 10 | | 20 | |

SPECIAL INSTRUCTIONS:

JAY WARE, Ware Disposal Inc.
Printed name (Owner/Manager)

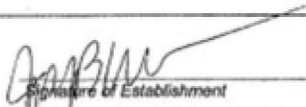

Signature of Establishment

27 February 2018
Date

Failure to comply with any stipulation outlined above may result in civil penalties pursuant to California Food and Agricultural Code Section 5705 and/or revocation of this Agreement.

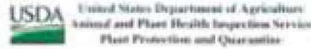

Compliance Agreement # 30-CIT245-0021

**EXHIBIT 1386-T
TRANSPORTER/HULER
OF MANDARINS WITH STEMS AND LEAVES**

**PROVISIONS FOR THE INTRASTATE MOVEMENT OF MANDARINS WITH ATTACHED STEMS AND/OR LEAVES
FROM OR WITHIN AN ASIAN CITRUS PSYLLID BULK CITRUS REGIONAL QUARANTINE ZONE**

To Be Used in Conjunction with Master Permit QC 1386

Establishment agrees to the following:

1. Establishments Under Compliance

- a. Ensure that mandarin fruit with attached stems and leaves being transported is produced by a grower/grover manager under compliance with the ACP Program.
 - i. Mandarins with stems and leaves must not originate or be processed in an area quarantined for Huanglongbing (HLB) or regulated for sweet orange scab (SOS); and
 - ii. The fruit must not be comingled with fruit that has been in an area quarantined for HLB or regulated for SOS.
- b. Ensure fruit is delivered to and handled by packers/processors under compliance with the Program.
Establishments operating under compliance can be verified online at:
https://www.cdfa.ca.gov/plant/acp/reg_establishments.html

2. Safeguarding

All shipments of mandarin fruit with attached stems and leaves must be safeguarded the entire time while in transit, beginning before the vehicle departs the loading site and until it reaches final destination for offloading. Any screen mesh used as an ACP-proof barrier shall be 0.3 square millimeters (e.g. 0.547 x 0.547, or 0.5 x 0.6) or less in size. Approved safeguarding measures include the following:

- a. Mandarin fruit is transported in a fully enclosed vehicle, or
- b. Transporting vehicles which have solid wall construction on sides and rear; a solid tarpaulin or ACP-proof barrier shall cover the top. The tarp or ACP-proof barriers shall be in good repair without tears or holes and be securely fastened to the solid walls of the truck, ensuring no gaps are present and in a manner that would prevent exposure to ACP or the loss of fruit, leaves, stems, branches, and plant debris while in transit, or
- c. Transporting vehicles constructed of wire mesh or expanded metal shall be completely covered with a solid tarp or ACP-proof barriers that extend down to the truck bed, ensuring no gaps are present. The tarp or ACP-proof barrier shall be in good repair without tears or holes and be securely fastened to the bed of the truck in a manner that would prevent exposure to ACP or the loss of fruit, leaves, stems, branches, and plant debris while in transit, or
- d. Transporting vehicles which have a flatbed trailer with field pallets or bins shall be entirely covered to the bed of the truck with a solid tarp or ACP-proof barrier. The tarp or screen mesh shall be in good repair without tears or holes and be securely fastened to the bed of the truck, ensuring no gaps are present around the bins, and in a manner that would prevent exposure to ACP or the loss of fruit, leaves, stems, branches, and plant debris while in transit, or
- e. Any other Program approved manner specified in the "Special Instructions."

3. Transporter Cleanliness

The vehicle and/or trailer used for transporting the shipment must be free of all leaf and stem debris and free of all life stages of ACP prior to transport and after delivery.

4. Evidence of Compliance

Place a copy of the compliance agreement, this exhibit, and the applicable "ACP-Free Declaration" form in each transport vehicle.

12/27/2017

Page 1 of 2

- 5. Direct Route**
 Take the most continuous, direct route, without interruption to a Program approved receiver.
- 6. Green Waste Disposal**
 All green waste, including leaf and stem debris, shall be continuously collected, safeguarded, and disposed of in accordance with the Program, local County Agricultural Commissioner, under QC Master Permit 1289 or other Program approved manner.
- 7. Records**
 Maintain records of all ACP host shipments for a minimum of two years and make such records available to Program officials immediately upon request.
- 8. Training**
 Ensure all employees receive training to be compliant with all specifications of the compliance agreement and this exhibit.
- 9. Spill Notification**
 Notify the Program as soon as possible and no later than 24 hours after spillage of any shipment.
- 10. Vehicle Tracking System**
 List all truck and trailer license plates below. Update the Program immediately any time license plates are added, changed, or are no longer in use. If more space is needed, continue on the back of this exhibit or attach pages as necessary.
- 11. Violation**
 Violation of any terms of the compliance agreement or this exhibit shall result in the suspension of the compliance agreement until an investigation is completed and for a minimum period of two weeks.

Transporter License Plates Will be provided once vehicles have been procured.

| | | | |
|---|--|----|--|
| 1 | | 8 | |
| 2 | | 9 | |
| 3 | | 10 | |
| 4 | | 11 | |
| 5 | | 12 | |
| 6 | | 13 | |
| 7 | | 14 | |

SPECIAL INSTRUCTIONS: _____

JAY WARE, Ware Disposal Inc.
 Printed name (Owner/Manager)

 Signature of Establishment

27 February 2018
 Date

Failure to comply with any stipulation outlined above may result in civil penalties pursuant to California Food and Agricultural Code Section 5705 and/or revocation of this Agreement.

Exhibit 17 – Contractor Documentation

Item B.21 - Contamination Monitoring Plan

This item consists of 4 pages (including this page).

In accordance with Section 18984.5 of the SB 1383 regulations Ware Disposal will, at its sole expense, conduct hauler route reviews for prohibited container contaminants in each customer's recycling and organic waste containers. The reviews will be done in a manner that is deemed safe; is approved by the County and results in all hauler routes being reviewed at a minimum annually.

Additionally, Ware Disposal, at the request of the County will conduct route reviews for contamination minimization with large organic waste customers once per quarter. Large organic waste customers will be identified as customers who have 4 CY or more of organic waste collection once per week.

Ware Disposal will develop a hauler route review methodology to minimize container contaminants in collection containers and such methodology shall comply with the requirements of 14 CCR Section 18984.5(b). Ware Disposal will submit its proposed hauler route review methodology to the County for approval. Ware Disposal's proposed hauler route review methodology will include not only its plan for container inspections, but also may include physical visual inspections of containers by Ware Disposal drivers using video screen monitoring to capture contamination of customers out of compliance. Ware Disposal may commence with the proposed methodology upon approval.

Today, the average contamination rate among communities and businesses sits at around 25%. That means that roughly 1 in 4 items placed in a recycling container is actually not recyclable through curbside programs, and this creates enormous problems for the recycling economy. Contamination significantly increases the cost to process recyclables while commodity prices for recyclables has fallen significantly.

The higher the recycling contamination, the less we can recycle – that is the challenge we are all facing, and it is a national problem.

Ware Disposal's recycling containers shall be considered contaminated if it contains more than twenty percent (20%) non-recyclable material by weight or volume. The organic waste containers shall be considered contaminated if it contains more than twenty percent (20%) non-organic waste material by weight or volume.

Ware Disposal will take appropriate actions following contamination monitoring. These actions will be submitted for approval to the County and will likely include but not limited to the following:

| Item | Description |
|--------------------------|---|
| 1 st Incident | <p>Upon finding Container Contaminants, Ware Disposal will photograph and provide written notice to the customer. Written notice will include information regarding properly separating materials and will be left on the container, at the door, and/or notice may be mailed, emailed, or electronically messaged so that customer receives the notice prior to the next Collection.</p> <p>The below proposed format of the contamination notification and disposal will include the following and will be submitted to the County for approval prior to implementation:</p> <ol style="list-style-type: none"> a. The number of Hauler Route reviews conducted. b. Description of Ware Disposal’s process for determining the level of contamination; c. Summary report of non-Collection notices, and courtesy Collection notices issued, which for each notice shall include the date of issuance, Customer name, and service address. d. A record of each inspection and contamination incident, which shall include, at a minimum: <ul style="list-style-type: none"> – Name of the Customer – Address of the Customer – The date the contaminated Container was observed – The staff who conducted the inspection – The total number of violations found and a description of what action was taken for each – Copies of all notices issued to Generators with Prohibited Container Contaminants |

| | |
|------------------------------------|---|
| | – Any photographic documentation or supporting evidence. |
| 2 nd Incident | If a second incident is observed, Ware Disposal will provide a photograph and written notice to the customer and provide a warning to the customer that they will be charged a contamination fee if no compliance is attained by next collection day. |
| 3 rd Incident | If third incident is observed, Ware Disposal will provide a photograph, written notice, and shall collect the contaminated container and may charge the customer a contamination fee. Prior to executing any of the following: Non-collection, extra fees or charges, and any recommended actions Ware Disposal will submit to the County for approval before implementing, which would include photographic evidence along with justification. |
| Disposal of Contaminated Materials | When container contaminants in a customer's container(s) is observed, Ware Disposal will dispose of the container's contents, following compliance, notification and approval by County of requirements set forth above. |
| Additional Requirements | Any other information reasonably requested by the County or specified in contamination monitoring provisions of this Agreement. |

Exhibit 17 – Contractor Documentation

Item B.22 - Procurement of Recovered Organic Waste Products (Item J4 of Exhibit 3A1)

This item consists of 3 pages (including this page).

Alternative procurement amount shall be equivalent to RNG procurement amounts of 25% of total fuel usage for the Service Area. The amounts specified are provided above in Environmental Programs, page 39 of this document. Ware Disposal will meet SB 1383 procurement obligations for the County through partnership with U.S. Gain, a division of U.S. Venture Inc., a leader in development and distribution of alternative fuel and renewable natural gas. U.S. Gain has committed to piping in SB 1383 qualified RNG directly to Ware Disposal’s Fullerton yard where all Ware Disposal trucks will refuel overnight. The utilization of onsite fueling will reduce driver time and operational costs through elimination of time spent refueling, reducing Ware Disposal’s environmental footprint, positively impacting County congestion and air quality. We will also provide mulch and compost without charge at the County’s direction.

| Environmental Program | Specifications | Diversion Impact |
|--|---|--|
| Procuring buy-recycled products and minimum recycled-content | Ware Disposal will help the County meet its SB 1383 procurement requirements with its entire fleet of CNG trucks used in the service area. Ware Disposal will procure 25% of its natural gas as CRNG from U.S. Gain based in Compton. | |
| Alternative SB 1383 Procurement Requirement (by Service Area) 25% Procurement | | |
| San Gabriel Valley West | Estimation Method: 50 DGEs per day x 25 trips week x 52 weeks = 65,000 TTL DGEs x 25% | 16,250 DGEs |
| Bulk Compost and Mulch | Bulk Compost and/or Mulch Giveaway – Ware Disposal will make available to the County bulk compost and mulch that meet requirements defined in SB 1383, and shall transport such material to County locations and events upon request, for County use in parks and facilities, or for resident usage, at no cost | This amount is estimated to be range from 80 tons to 160 tons per year |



June 30, 2021

Via Email

Re: RNG Delivered to Ware Disposal CNG station

Dear Administrator,

This letter shall serve as Clean Energy's confirmation that Ware Disposal will receive 100% RNG supply when fueling at its CNG fueling station in Fullerton, California.

Clean Energy sources RNG from an established portfolio of producers across North America. The RNG Clean Energy delivers into the vehicle fuel market is from EPA and California Air Resource Board (ARB) registered RNG production facilities.

The station above dispensed 100% RNG in 2020, and Clean Energy will continue provide RNG to this station, along with the rest of our California CNG infrastructure. While a portion of our RNG supply includes RNG produced in California, this volume cannot be guaranteed, and we will deliver California RNG on an as-available basis.

If you need any further information or wish to discuss Clean Energy's RNG supply, please feel free to reach out to Sahar Kamali at 949-437-1260 or Sahar.kamali@cleanenergyfuels.com.

Sincerely,

Sahar Kamali
Director, Sustainability
Clean Energy