

Approved

  
Diego Cadena

June 30, 2009

TO: Diego Cadena  
Deputy Director

FROM: Dennis Hunter   
Land Development Division

### **PRIVATE DRIVES AND TRAFFIC CALMING DESIGN GUIDELINES MANUAL**

A Private Drive is a privately maintained roadway that will not be eligible for transfer to Los Angeles County for ownership or maintenance. Developers are increasingly proposing and/or requesting to incorporate Private Drives to provide internal circulation within their developments. As a result, we prepared the attached document as part of a collaborative effort to develop guidelines for the inclusion of Private Drives within new proposed tract developments.

These guidelines have been established to ensure the use of minimum design standards for emergency vehicles as well as assist in the review of tentative maps and necessary conditions of approval and the review and approval of corresponding improvement plans. They incorporate street elements such as centerline radii, street grades, widths, parkways, and sidewalks, which have been modified to achieve minimum design criteria for Private Drives.

This manual will assist developers in streamlining the review and approval process for projects incorporating Private Drives within the County, leading to improved customer service. The guidelines were presented to the Land Development Advisory Committee in February 2009 and are intended to be a living document subject to future revisions as deemed necessary.

Upon your approval, we will implement these new design practices into our project review process.

AN:la

P:\dpub\ADMIN\LINDA\PRIVEATE DRIVE & TRAFFIC CALMING MANUAL.doc

Attach.

cc: Department of Regional Planning (Susie Tae)  
Fire Department (Jenna Masi)

bc: Building and Safety, Operational Services, Road Maintenance, Traffic and Lighting,  
Watershed Management, Land Development (Hunter, Burger, Ibrahim, Pachano)





*Public Works*  
LOS ANGELES COUNTY

**County of Los Angeles Department of Public Works**

**Private Drives and Traffic Calming  
Design Guidelines Manual**

---

**June 2009**

Table of Contents

**1) INTRODUCTION.....1**

**2) DESIGN GUIDELINES .....2**

    a. Design Speed .....2

    b. Sight Distance .....2

    c. Horizontal Geometry .....2

        i. Centerline Curve Alignment .....2

        ii. Intersection Design .....3

        iii. Tangents .....3

        iv. Medians .....3

        v. Curb Extensions .....3

        vi. Roundabouts and Traffic Circles .....4

        vii. Gates .....4

    d. Vertical Design .....4

        i. Grades .....4

        ii. Landings .....4

        iii. Grade Breaks and Vertical Curves .....5

    e. Signing and Striping .....5

    f. Structural Design .....5

        i. Pavement Design .....5

        ii. Design Criteria .....5

**3) IMPLEMENTATION .....6**

    a) Tentative Map .....6

    b) Final Engineering .....6

    c) Construction .....6

**4) ACKNOWLEDGMENTS.....7**

    Document Preparation Team

    Special Acknowledgment

**5. APPENDIX.....8**

    Fig.1a Private Drive-Local Cul-De-Sac w/Parallel Parking ..... A-1

    Fig.1b Private Drive-Local-No Parking ..... A-2

    Fig.2a Private Drive-Residential Collector w/Parallel Parking ..... A-3

    Fig.2b Private Drive-Residential Collector w/Mountable Median Curb-No  
        Parking ..... A-4

    Fig.2c Private Drive-Residential Collector w/Mountable Median Curb-No  
        Parking ..... A-5

    Fig.3a Private Drive-Rural w/Parallel Parking ..... A-6

    Fig.3b Private Drive-Rural w/Inverted Shoulder ..... A-7

    Fig.4 Private Drive-Gated Entry Residential ..... A-8

    Fig.5 Private Drive-Urban w/Parallel Parking ..... A-9

Fig.6a Private Drive-Local Collector-No Median w/Angled Parking .....	A-10
Fig.6b Private Drive-Local Collector w/ Median w/Angled Parking .....	A-11
Fig.6c Private Drive-Local Collector-w/Median w/Angled Parking .....	A-12
Fig.7a Private Drive-One Way w/Parallel Parking On One Side .....	A-13
Fig.7b Private Drive-One Way-No Parking .....	A-14
Fig.8a Private Drive-Alley-No Fire Access .....	A-15
Fig.8b Private Drive-Alley .....	A-16
Fig.9 Industrial/Commercial Loop-Private Drive .....	A-17
Fig.10 Typical Gate Detail With Guard Shack .....	A-18
Fig.11 Typical Gate Detail Without Guard Shack .....	A-19
Fig.12 Typical Private Drive Local Intersection 3-Way Traffic Calming Detail .....	A-20
Fig.13 Mid Block Traffic Calming Detail .....	A-21
Fig.14 Typical Horizontal Geometry Private Drive Rural .....	A-22
Fig.15 Concrete Rolled Curb .....	A-23

## **Section 1 Introduction**

Developers are increasingly proposing and/or requesting to incorporate "private drives" within their developments. The intent is to provide a local circulation system that encompasses the concept of smart growth and livable communities, land planning principles, aesthetics and water quality while balancing traffic flow, pedestrian safety, and maintaining access for emergency vehicles.

A Private Drive, as referred to in these guidelines, is defined as a local road that will be privately maintained and will not be eligible for transfer to Los Angeles County for ownership nor maintenance.

Specific design elements may be modified to accommodate the Low-Impact Development (LID) Ordinance adopted by the County of Los Angeles.

Street elements have been modified to achieve design criteria for private drives. These elements include: centerline radii, street grades, street widths, parkways, and sidewalks.

The following references were used to develop the design criteria for private drives (but were modified where necessary to incorporate the various elements listed above).

- Los Angeles County Title 21
- Los Angeles County Fire Design Guidelines
- AASHTO
- FHWA
- California Department of Transportation (Caltrans)

These guidelines have been established for the following reasons.

- To ensure that private drives incorporate minimum access design standards for emergency vehicles.
- To assist in the review of tentative maps, preparing conditions of approval for corresponding tract development, and reviewing and approving corresponding plans.

Design speeds and sight distance criteria utilized for these guidelines are based upon AASHTO, Los Angeles County, and Caltrans standards, where appropriate. All design charts and tables in the available publications are referenced herein.

This manual will be a living document and may be periodically revised or updated.

## **Section 2 Design Guidelines**

This section establishes the design guidelines and criteria to be used in designing and reviewing the Private Drives located in the Westside Communities. The criteria contained herein, are the minimum design criteria for specific classifications of Private Drives. The specific cross-sections and design criteria are located in the Appendix. A discussion of the standards and criteria to be used follows below.

### a) Design Speed

Alleys	Minimum design speed of 15 mph.
Local (through) streets:	Minimum design speed of 20 mph.
Collectors:	Minimum design speed of 30 mph.
Hillside conditions:	Minimum design speed of 15 mph (Local) Minimum design speed of 25 mph (Collector)

"Hillside conditions" will be defined as consistent with the latest County designation for streets.

#### Design Exceptions:

Where design constraints or site design elements require the use of reduced design speeds or centerline radii, exceptions may be allowed with LACDPW approval. The designer must demonstrate that the land use, traffic volumes, and signage are appropriate for the design exception requested.

### b) Sight Distance

Stopping sight distance and intersection sight distance should be based upon the design speed shown on the private drives cross-sections and the criteria defined in the AASHTO guidelines.

Where medians are utilized, landscaping and obstructions within the medians need to be minimized within the stopping and intersection sight distance setbacks.

### c) Horizontal Geometry

#### i) Centerline Curve Alignment

The minimum centerline curve radii used for standard local and collector private drives are defined in the typical design sections following. In hillside conditions, reduced centerline curve radii are utilized consistent with the

reduced design speeds. AASHTO guidelines allow radii as low as 100 feet for local streets. The minimum length of all curves is 100 feet, measured outside of the intersection curb returns.

ii) Intersection Design

Intersecting drives should intersect as close to 90 degrees as possible. The maximum angle of deflection between two intersecting private drive centerlines is 20 degrees.

Per AASHTO, intersection sight distance should be based upon a 7 second minimum for a driver of a passenger vehicle to pass through the through lanes. Where adequate sight distance cannot be provided for 4-way intersections, adequate controls consistent with Section e. Signing and Striping shall be utilized.

iii) Tangents

Short tangents between successive curves should be avoided. Minimum tangents for reversing and broken back curves are included on the design cross sections located in the Appendix.

Where adequate tangents cannot be provided, reversing and compound curves with no tangents should be utilized. For compound curves, the radius of the smaller curve must be a minimum 2/3 of the larger radius.

iv) Medians

Medians can be utilized for aesthetics and traffic calming purposes. When utilized, medians will have a minimum width of 14 feet unless otherwise approved. Landscaping and visual obstructions in the medians must be minimized within the intersection and stopping sight distance lines of sight.

Medians exceeding 400 feet must be broken, or a mountable and hard drivable surface added at a maximum distance of 400 feet if no emergency turnaround or alternate route is available for emergency vehicles. All drivable surfaces must be designed to accommodate the wheel loads of the County Fire Department design vehicles.

v) Curb Extensions

Restricting the width of intersections through the use of "curb extensions" may be desired to promote traffic calming and pedestrian safety. The location and frequency of the curb extensions are to be based upon the recommendations of the traffic consultant and subject to County approval. Typical details can be found in the Appendix.

vi) Roundabouts and Traffic Circles

If a roundabout is utilized for traffic factors, the design must be consistent with the latest “Roundabout Policy and Practices for Los Angeles County”

Traffic circles may be utilized for architectural and / or aesthetic purposes where low traffic volumes are expected. The designer must demonstrate that a fire truck and tractor trailer truck can safely negotiate the traffic circle. Intersection and stopping sight distance requirements must also be satisfied. Design vehicles utilized will be based upon the latest LACDPW and LACFD design guidelines.

vii) Gates

The design and dimensions of all gated entries should be based upon the stacking distance determined by a traffic analysis and approved by the County. The stacking distance must be adequate to eliminate queuing onto public streets during peak hours of operation. The minimum dimensions for a gated entry can be found in the Appendix.

d) Vertical Design

i) Grades

The maximum centerline grade of 10% will be allowed for standard local and collector private drives. In hillside conditions, a maximum of 15% is allowed with the following constraints:

- All effort should be made to use a maximum grade of 10%.
- The use of grades over 10% result in reduced grading or visual impacts.
- No intersections are allowed where grades exceed 10%.
- Grades greater than 10% should be utilized for short distances.
- When grades exceed 10%, the maximum grade differential between the adjacent incoming street grades is 5%.

ii) Landings

Landings are required on all side private drives entering the main private drive. A maximum landing grade of 3% will be used in all conditions with the exception of hillsides, where 5% may be utilized.

The minimum landing length is included in the typical design cross-sections in the Appendix. The landing is defined as that portion of the side street beyond the curb projection of the through street.



iii) Grade Breaks and Vertical Curves

A maximum grade break of 1% every 15 feet is allowed.

Where grade breaks exceed 1%, vertical curves will be utilized, consistent with the Caltrans Highway Design manual.

e) Signing and Striping

All signing and striping should be based upon the Manual on Uniform Traffic Control Devices (MUTCD) consistent with AASHTO, Caltrans guidelines, and the California Vehicle Code. Directional and warning signage and striping should be used as required for safety

f) Structural Design

i) Pavement Design

All standard pavement, enhanced pavement, and pavers structural sections should be designed consistent with the guidelines outlined in the Caltrans and AASHTO design manual, or applicable manufacturer's design specifications.

ii) Design Criteria

All design should be based upon a reasonable TI (Traffic Index) provided by a traffic engineer. The pavement section must be designed to accommodate a LACFD design vehicle (75,000 pounds), as well as the standard Caltrans design vehicle. A minimum TI of 4 is recommended by the Fire Department for access limited to emergency vehicles. A soils consultant shall be employed to provide recommendations for structural sections.

### **Section 3 Implementation**

This section establishes the procedures and process for the planning and design phases of the project.

a) Tentative Map

The LACDPW Land Development Division - Road and Grading Section will review all proposed private drives for adherence to the guidelines and design criteria established in these guidelines. The LACDRP and LACFD may also review and comment on the proposed use of private drives and address any discretionary approvals required by these guidelines. All Conditions of Approval corresponding to private drives will be prepared in reference to these guidelines. However, LACDPW Land Development Division may use their discretion if the use of a proposed cross section is deemed undesirable.

b) Final Engineering

All private drives will be reviewed by the LACDPW Land Development Division – Road and Grading Section for adherence to the guidelines and design criteria established in these guidelines.

LACDPW Geotechnical and Materials Engineering Division - Soils and Geology Section will review the pavement structural sections.

Private drive details will be reviewed as part of the grading improvement plans and will consist of 1"=40' plans with a centerline profile. The plans will include street stationing, horizontal and vertical geometry annotation, and construction notes.

Plan check fees will be based upon the valuation of the proposed improvements consistent with normal road and grading plan check fees.

c) Construction

All construction will be supervised as a part of the grading permit. Construction of the road structural section will be confirmed by the soils engineer and included with the final grading certification. The civil engineer will certify that the drainage and grading improvements have been constructed as shown on the plan.

## **Section 4 Acknowledgements**

### **Document Preparation Team**

The following members of the Private Drives and Traffic Calming Design Guidelines Manual Committee contributed to the formulation of this document:

Andy Narag – Land Development

Sam Richards – Land Development

Steve Sheridan – Land Development

Janna Masi – Fire Department

### **Special Acknowledgement**

Public Works would like to acknowledge and thank the following individuals for providing technical support in the formulation of this document.

Mr Jason H. Fukumitsu, P.E.  
Hunsaker and Associates, LA, Inc.  
26074 Avenue Hall, #23  
Valencia, California 91355  
Office. (661) 294-2211  
E-mail [jfukumitsu@hunsaker.com](mailto:jfukumitsu@hunsaker.com)

A special thank you to Corey Harpole, Newhall Land, who provided funding and moral support in the formulation of this document.

## **Section 5 Appendix**

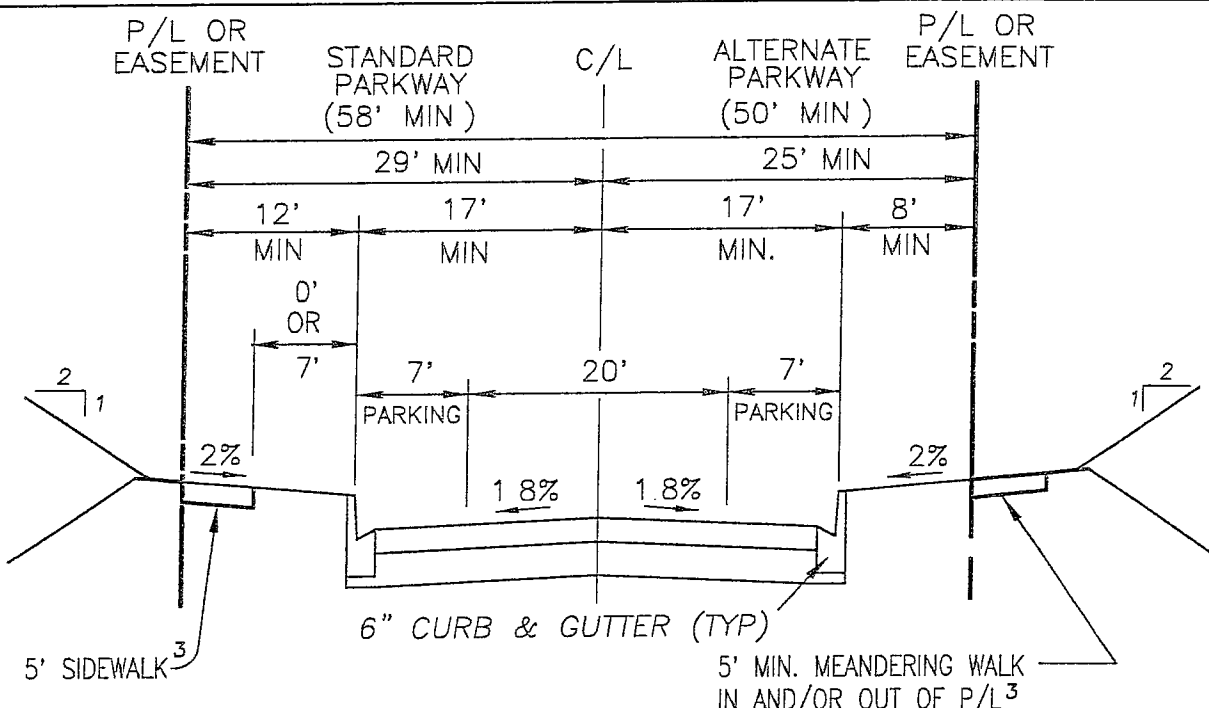

**1a PRIVATE DRIVE-LOCAL CUL-DE-SAC<sup>4</sup>  
W/ PARALLEL PARKING**

N.T.S.

**DESIGN DATA**

	STANDARD	ALTERNATE
MIN. OVERALL WIDTH (ft)	58	50
MIN. CURB TO CURB WIDTH (ft)	34	34
MIN. SIDEWALK WIDTH (ft)	5	5
LAND USE	SINGLE FAMILY RESIDENTIAL, DETACHED CONDOMINIUMS, DUPLEXES, LOCAL MIXED USE, OPEN SPACE, PARK	
ADT VOLUME (SF UNITS SERVED) <sup>2</sup>	900 ADT(100)	
	STANDARD	HILLSIDE
DESIGN SPEED (mph)	20	15
MINIMUM C/L RADIUS (ft)	100	100
MIN. TANGENT REVERSING CURVE (ft) <sup>1</sup>	100	100
MIN. TANGENT BROKEN BACK CURVES (ft) <sup>1</sup>	200	150
COMPOUND CURVE RADII (ft)	$\frac{2}{3}R_1 \leq R_2 \leq R_1$	$\frac{2}{3}R_1 \leq R_2 \leq R_1$
MAXIMUM GRADE	10%	15%
MAXIMUM LANDING GRADE	3%	5%
MINIMUM LANDING LENGTH (ft)	50	25
RESTRICTIONS	MAY BE USED AS ACCESS TO MULTI-FAMILY <35' IN HEIGHT ON A CASE BY CASE BASIS. MAXIMUM CUL-DE-SAC LENGTH=700'	

1. ELIMINATE TANGENT IF MINIMUM TANGENT LENGTH CANNOT BE SATISFIED.
2. ADT VOLUME ANALYSIS IS THE BASIS OF DESIGN AND SUPERCEDES UNITS OR BUILDING AREA.
3. BASE MAY BE REQUIRED PER SOILS ENGINEER'S RECOMMENDATIONS.
4. MAY BE APPROVED AS A THROUGH STREET ON A CASE BY CASE BASIS.

DATE: JUNE 2009

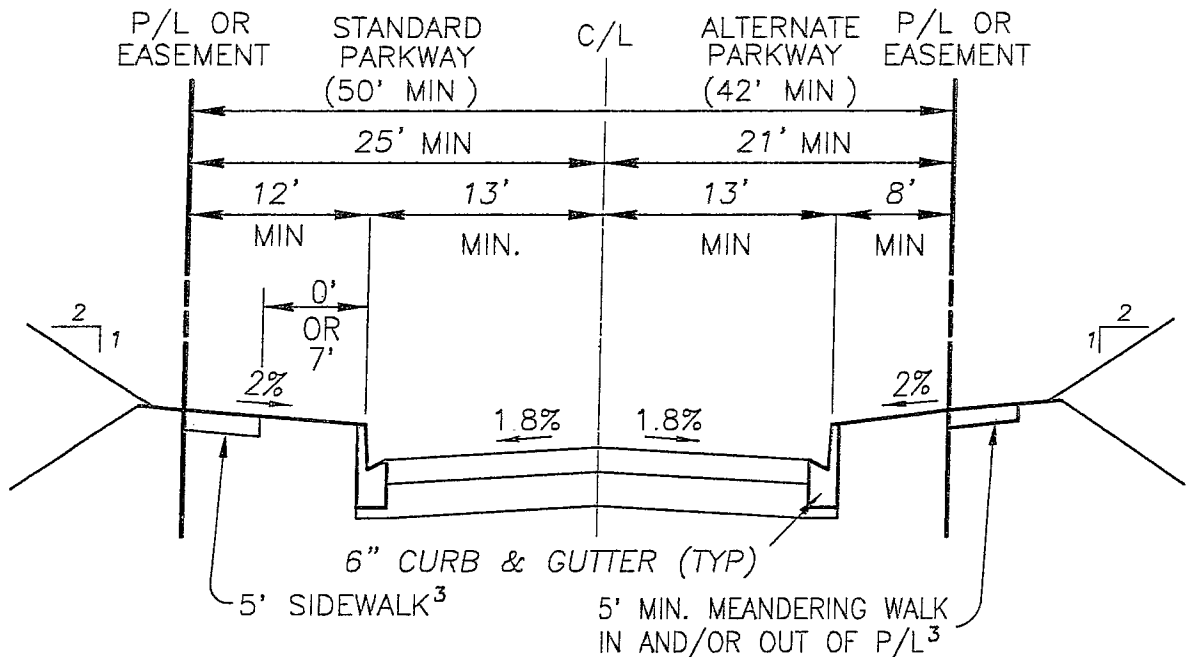

**1b PRIVATE DRIVE-LOCAL<sup>4</sup>**  
**NO PARKING**  
 N.T.S.

**DESIGN DATA**

	STANDARD	ALTERNATE
MIN. OVERALL WIDTH (ft)	50	42
MIN. CURB TO CURB WIDTH (ft)	26	26
MIN. SIDEWALK WIDTH (ft)	5	5
LAND USE	SINGLE FAMILY RESIDENTIAL, DETACHED CONDOMINIUMS, DUPLEXES, MULTI-FAMILY RESIDENTIAL, LOCAL MIXED USE, OPEN SPACE, PARK	
ADT VOLUME (SF UNITS SERVED) <sup>2</sup>	3,600 ADT(400)	
	STANDARD	HILLSIDE
DESIGN SPEED (mph)	25	15
MINIMUM C/L RADIUS (ft)	200	100
MIN. TANGENT REVERSING CURVE (ft) <sup>1</sup>	100	100
MIN. TANGENT BROKEN BACK CURVES (ft) <sup>1</sup>	200	150
COMPOUND CURVE RADII (ft)	$\frac{2}{3}R1 \leq R2 \leq R1$	$\frac{2}{3}R1 \leq R2 \leq R1$
MAXIMUM GRADE	10%	15%
MAXIMUM LANDING GRADE	3%	5%
MINIMUM LANDING LENGTH (ft)	50	25
RESTRICTIONS	RESTRICTED OR LIMITED DRIVEWAY ACCESS, NO PARKING, NO EMERGENCY FIRE SETUP REQUIRED FOR BUILDINGS, ENTRY OR STRUCTURES LESS THAN 35' SUBJECT TO REVIEW.	

1. ELIMINATE TANGENT IF MINIMUM TANGENT LENGTH CANNOT BE SATISFIED.
2. ADT VOLUME ANALYSIS IS THE BASIS OF DESIGN AND SUPERCEDES UNITS OR BUILDING AREA.
3. BASE MAY BE REQUIRED PER SOILS ENGINEER'S RECOMMENDATIONS.
4. CAN BE USED AS A COLLECTOR ON A CASE BY CASE BASIS.

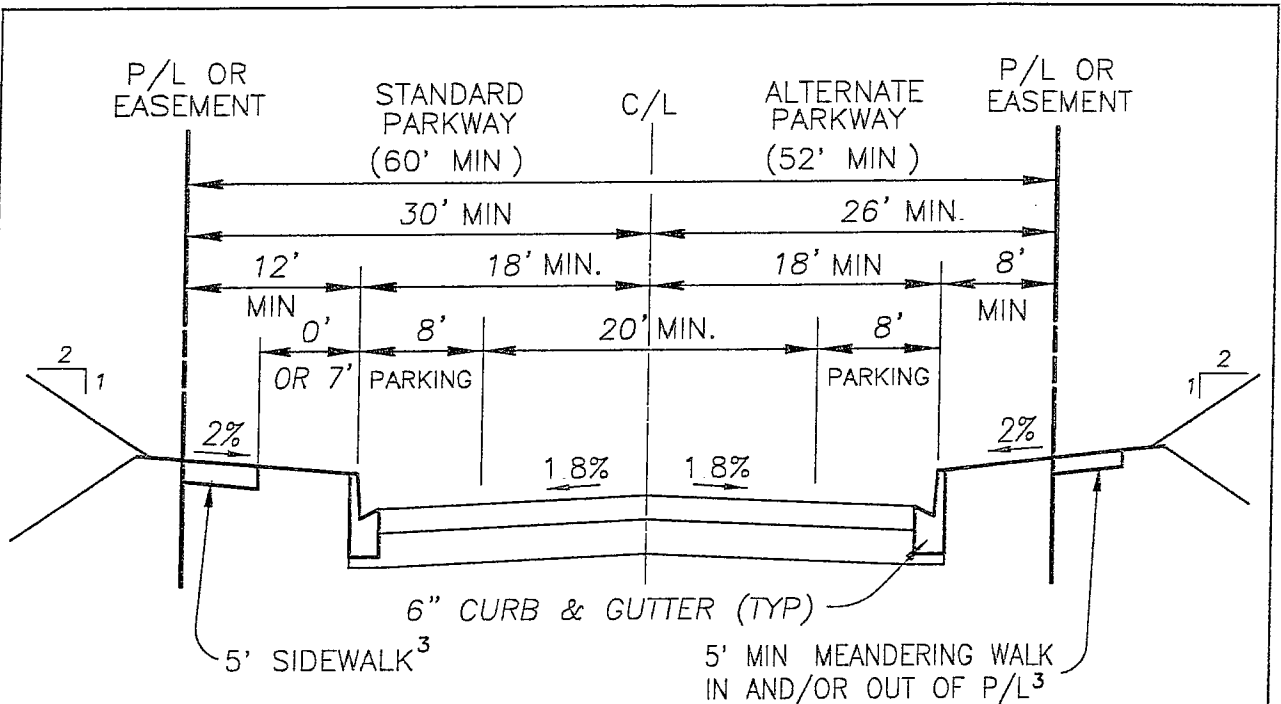

**2a PRIVATE DRIVE-RESIDENTIAL COLLECTOR  
W/ PARALLEL PARKING**

N.T.S.

**DESIGN DATA**

	STANDARD	ALTERNATE
MIN. OVERALL WIDTH (ft)	60	52
MIN. CURB TO CURB WIDTH (ft)	36	36
MIN. SIDEWALK WIDTH (ft)	5	5
LAND USE	SINGLE FAMILY RESIDENTIAL, DETACHED CONDOMINIUMS, MULTI-FAMILY RESIDENTIAL<35', LOCAL MIXED USE, OPEN SPACE, PARK	
ADT VOLUME (SF UNITS SERVED) <sup>2</sup>	3,600 ADT(400)	
	STANDARD	HILLSIDE
DESIGN SPEED (mph) <sup>4</sup>	30	25
MINIMUM C/L RADIUS (ft)	250	150
MIN. TANGENT REVERSING CURVE (ft) <sup>1</sup>	100	100
MIN. TANGENT BROKEN BACK CURVES (ft) <sup>1</sup>	200	150
COMPOUND CURVE RADII (ft)	$\frac{2}{3}R1 \leq R2 \leq R1$	$\frac{2}{3}R1 \leq R2 \leq R1$
MAXIMUM GRADE	10%	15%
MAXIMUM LANDING GRADE	3%	5%
MINIMUM LANDING LENGTH (ft)	100	50
RESTRICTIONS		

1. ELIMINATE TANGENT IF MINIMUM TANGENT LENGTH CANNOT BE SATISFIED.
2. ADT VOLUME ANALYSIS IS THE BASIS OF DESIGN AND SUPERCEDES UNITS OR BUILDING AREA.
3. BASE MAY BE REQUIRED PER SOILS ENGINEER'S RECOMMENDATIONS.
4. LOWER DESIGN SPEEDS MAY BE UTILIZED CONSISTENT WITH THE MANUAL.

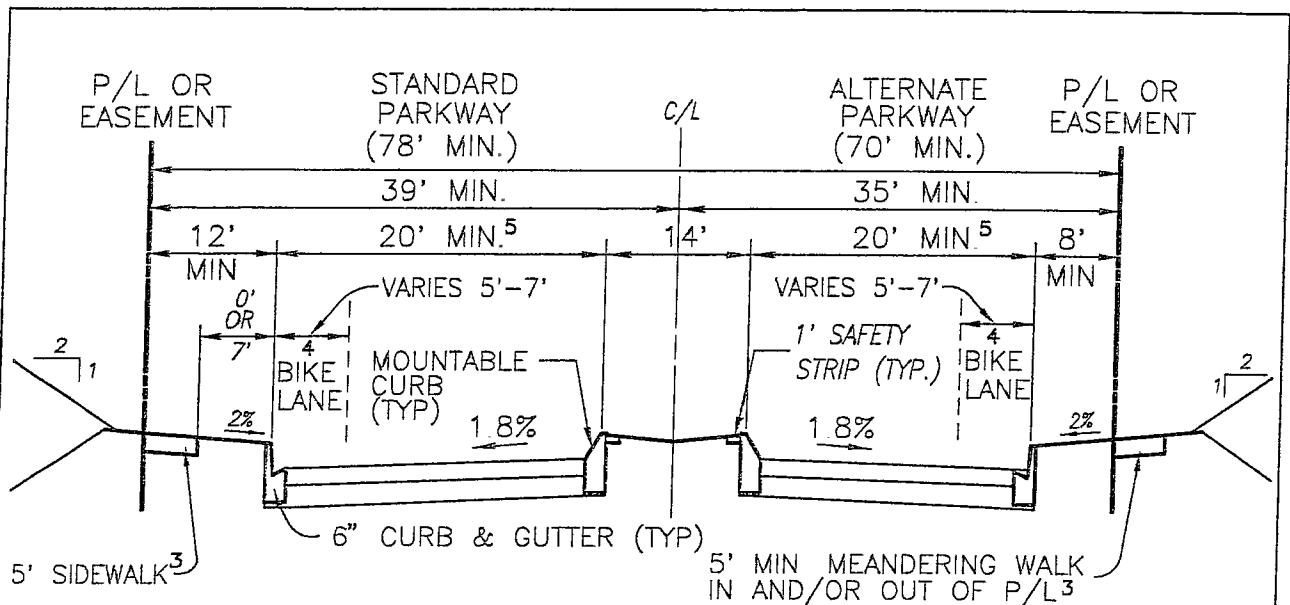

**(2b) PRIVATE DRIVE-RESIDENTIAL COLLECTOR<sup>5</sup>**  
**W/ MOUNTABLE MEDIAN CURB**  
**NO PARKING**  
*N.T.S.*

**DESIGN DATA**

	STANDARD	ALTERNATE
MIN. OVERALL WIDTH (ft)	78	70
MIN. CURB TO CURB WIDTH (ft)	54	54
MIN. SIDEWALK WIDTH (ft)	5	5
LAND USE	SINGLE FAMILY RESIDENTIAL, DETACHED CONDOMINIUMS, MULTI-FAMILY RESIDENTIAL, LOCAL MIXED USE, OPEN SPACE, PARK	
ADT VOLUME (SF UNITS SERVED) <sup>2</sup>	3,600 ADT(400)	
	STANDARD	HILLSIDE
DESIGN SPEED (mph) <sup>6</sup>	30	25
MINIMUM C/L RADIUS (ft)	250	150
MIN. TANGENT REVERSING CURVE (ft) <sup>1</sup>	100	100
MIN. TANGENT BROKEN BACK CURVES (ft) <sup>1</sup>	200	150
COMPOUND CURVE RADII (ft)	$\frac{2}{3}R_1 \leq R_2 \leq R_1$	$\frac{2}{3}R_1 \leq R_2 \leq R_1$
MAXIMUM GRADE	10%	15%
MAXIMUM LANDING GRADE	3%	5%
MINIMUM LANDING LENGTH (ft)	100	50
RESTRICTIONS	LIMITED DRIVEWAY ACCESS. MEDIAN PLANTING MUST ACCOMMODATE SIGHT DISTANCE AT INTERSECTIONS. ENTRY DRIVE OR STRUCTURES LESS THAN 35' SUBJECT TO REVIEW.	

1. ELIMINATE TANGENT IF MINIMUM TANGENT LENGTH CANNOT BE SATISFIED.
2. ADT VOLUME ANALYSIS IS THE BASIS OF DESIGN AND SUPERCEDES UNITS OR BUILDING AREA.
3. BASE MAY BE REQUIRED PER SOILS ENGINEER'S RECOMMENDATIONS.
4. BIKE LANE OPTIONAL—NOT REQUIRED.
5. WHEN ROAD ACCESS TO STRUCTURES IS NOT REQUIRED FOR EMERGENCY VEHICLES.
6. LOWER DESIGN SPEEDS MAY BE UTILIZED CONSISTENT WITH THE MANUAL.

DATE: JUNE 2009



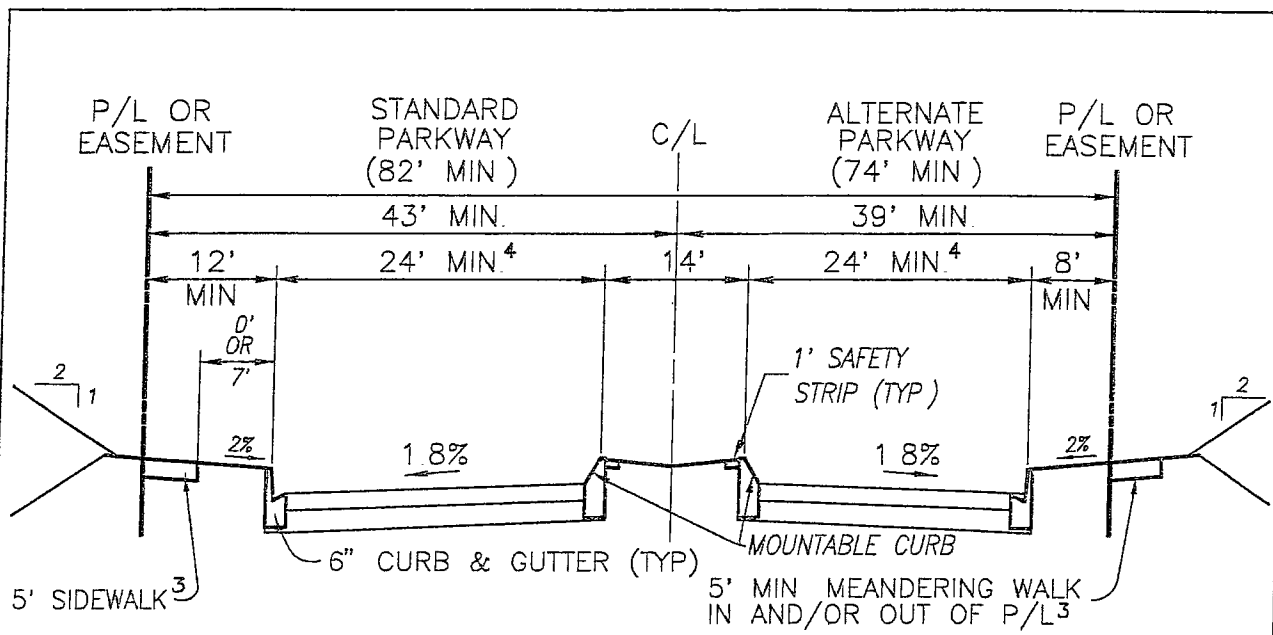

**2c PRIVATE DRIVE-RESIDENTIAL COLLECTOR<sup>4</sup>**  
**W/ MOUNTABLE MEDIAN CURB**  
**NO PARKING**  
*N.T.S.*

**DESIGN DATA**

	STANDARD	ALTERNATE
MIN. OVERALL WIDTH (ft)	82	74
MIN. CURB TO CURB WIDTH (ft)	62	62
MIN. SIDEWALK WIDTH (ft)	5	5
LAND USE	SINGLE FAMILY RESIDENTIAL, DETACHED CONDOMINIUMS, MULTI-FAMILY RESIDENTIAL, LOCAL MIXED USE, OPEN SPACE, PARK	
ADT VOLUME (SF UNITS SERVED) <sup>2</sup>	4,500 ADT(500)	
	STANDARD	HILLSIDE
DESIGN SPEED (mph) <sup>5</sup>	30	25
MINIMUM C/L RADIUS (ft)	250	150
MIN. TANGENT REVERSING CURVE (ft) <sup>1</sup>	100	100
MIN. TANGENT BROKEN BACK CURVES (ft) <sup>1</sup>	200	150
COMPOUND CURVE RADII (ft)	$\frac{2}{3}R1 \leq R2 \leq R1$	$\frac{2}{3}R1 \leq R2 \leq R1$
MAXIMUM GRADE	10%	15%
MAXIMUM LANDING GRADE	3%	5%
MINIMUM LANDING LENGTH (ft)	100	50
RESTRICTIONS	LIMITED DRIVEWAY ACCESS. MEDIAN PLANTING MUST ACCOMMODATE SIGHT DISTANCE AT INTERSECTIONS.	

1. ELIMINATE TANGENT IF MINIMUM TANGENT LENGTH CANNOT BE SATISFIED.
2. ADT VOLUME ANALYSIS IS THE BASIS OF DESIGN AND SUPERCEDES UNITS OR BUILDING AREA.
3. BASE MAY BE REQUIRED PER SOILS ENGINEER'S RECOMMENDATIONS.
4. WHEN ROAD ACCESS TO STRUCTURES IS REQUIRED FOR EMERGENCY VEHICLES.
5. LOWER DESIGN SPEEDS MAY BE UTILIZED CONSISTENT WITH THE MANUAL.

DATE: JUNE 2009

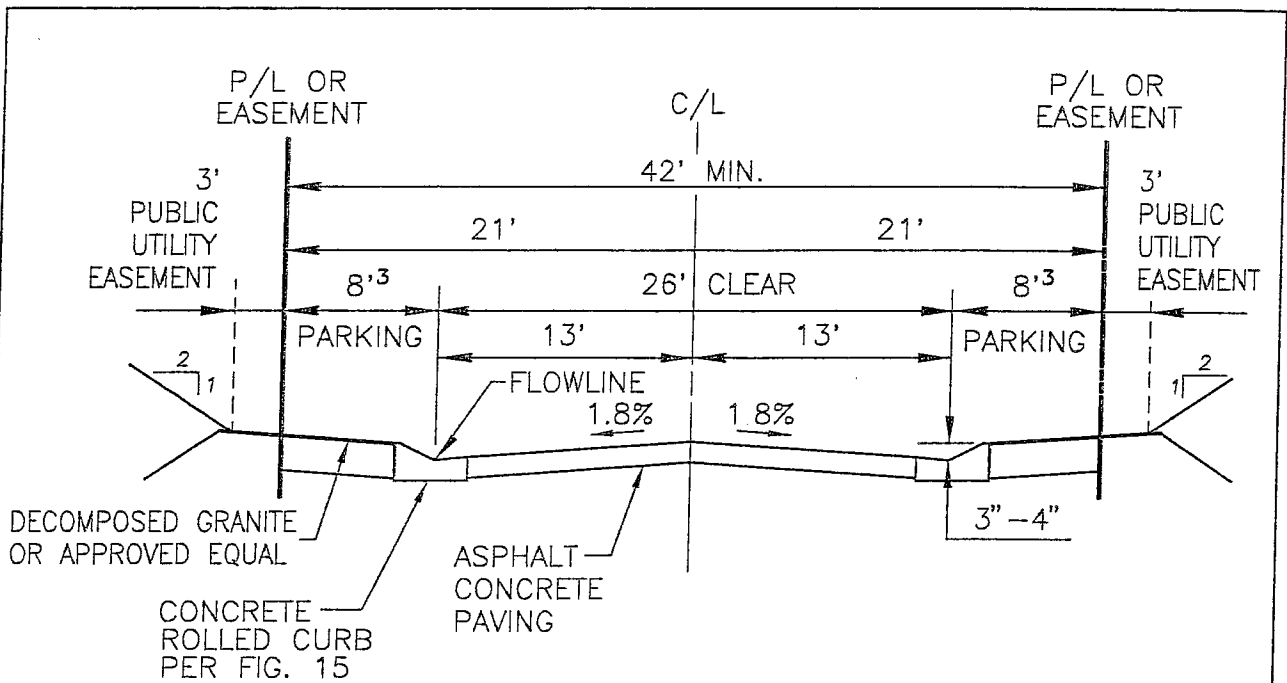

**3a** PRIVATE DRIVE-RURAL  
W/ PARALLEL PARKING  
N.T.S.

DESIGN DATA

	STANDARD	ALTERNATE
MIN. OVERALL WIDTH (ft)	42	N/A
MIN. CURB TO CURB WIDTH (ft)	N/A	N/A
MIN. SIDEWALK WIDTH (ft)	N/A	N/A
LAND USE	SINGLE FAMILY RESIDENTIAL ≤ 4 DUS/AC	
ADT VOLUME (SF UNITS SERVED) <sup>2</sup>	1,800 ADT(200)	
	STANDARD	HILLSIDE
DESIGN SPEED (mph)	25	15
MINIMUM C/L RADIUS (ft)	200	100
MIN. TANGENT REVERSING CURVE (ft) <sup>1</sup>	100	100
MIN. TANGENT BROKEN BACK CURVES (ft) <sup>1</sup>	200	150
COMPOUND CURVE RADII (ft)	$\frac{2}{3}R_1 \leq R_2 \leq R_1$	$\frac{2}{3}R_1 \leq R_2 \leq R_1$
MAXIMUM GRADE	10%	15%
MAXIMUM LANDING GRADE	3%	5%
MINIMUM LANDING LENGTH (ft)	50	25
RESTRICTIONS		

1. ELIMINATE TANGENT IF MINIMUM TANGENT LENGTH CANNOT BE SATISFIED.
2. ADT VOLUME ANALYSIS IS THE BASIS OF DESIGN AND SUPERCEDES UNITS OR BUILDING AREA.
3. OTHER IMPROVEMENTS, INCLUDING LANDSCAPING, STREET LIGHTS, FIRE HYDRANTS, UTILITY STRUCTURES AND OTHER FACILITIES MAY BE LOCATED WITHIN THE 8' PARKING AREA.

DATE: JUNE 2009

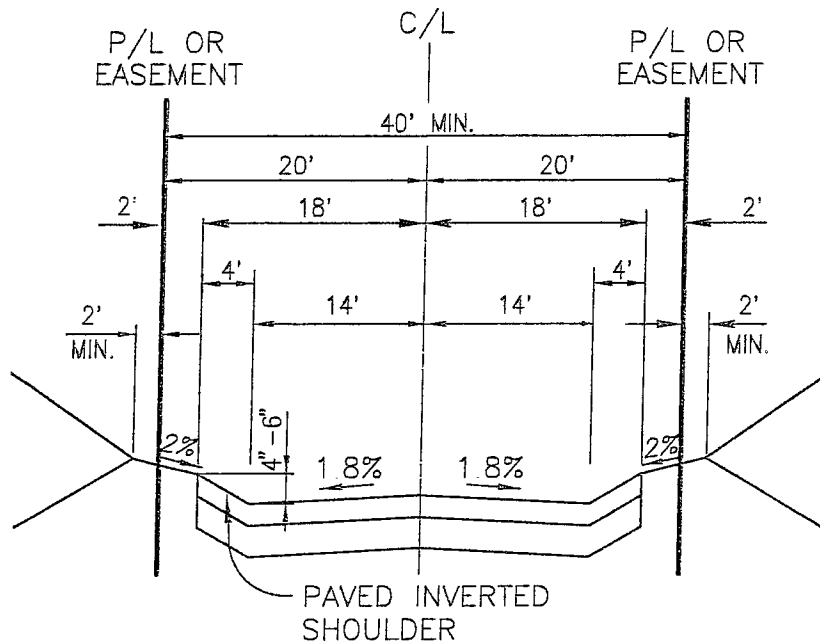

**3b PRIVATE DRIVE-RURAL  
W/ INVERTED SHOULDER**

**DESIGN DATA**

	STANDARD	ALTERNATE
MIN. OVERALL WIDTH (ft)	40	N/A
MIN. CURB TO CURB WIDTH (ft)	N/A	N/A
MIN. SIDEWALK WIDTH (ft)	N/A	N/A
LAND USE	SINGLE FAMILY RESIDENTIAL ≤ 4 DUS/AC	
ADT VOLUME (SF UNITS SERVED) <sup>2</sup>	900 ADT(100)	
	STANDARD	HILLSIDE
DESIGN SPEED (mph)	25	15
MINIMUM C/L RADIUS (ft)	200	100
MIN. TANGENT REVERSING CURVE (ft) <sup>1</sup>	100	100
MIN. TANGENT BROKEN BACK CURVES (ft) <sup>1</sup>	200	150
COMPOUND CURVE RADII (ft)	$\frac{2}{3}R_1 \leq R_2 \leq R_1$	$\frac{2}{3}R_1 \leq R_2 \leq R_1$
MAXIMUM GRADE	10%	15%
MAXIMUM LANDING GRADE	3%	5%
MINIMUM LANDING LENGTH (ft)	50'	25'
RESTRICTIONS		

1. ELIMINATE TANGENT IF MINIMUM TANGENT LENGTH CANNOT BE SATISFIED.
2. ADT VOLUME ANALYSIS IS THE BASIS OF DESIGN AND SUPERCEDES UNITS OR BUILDING AREA.

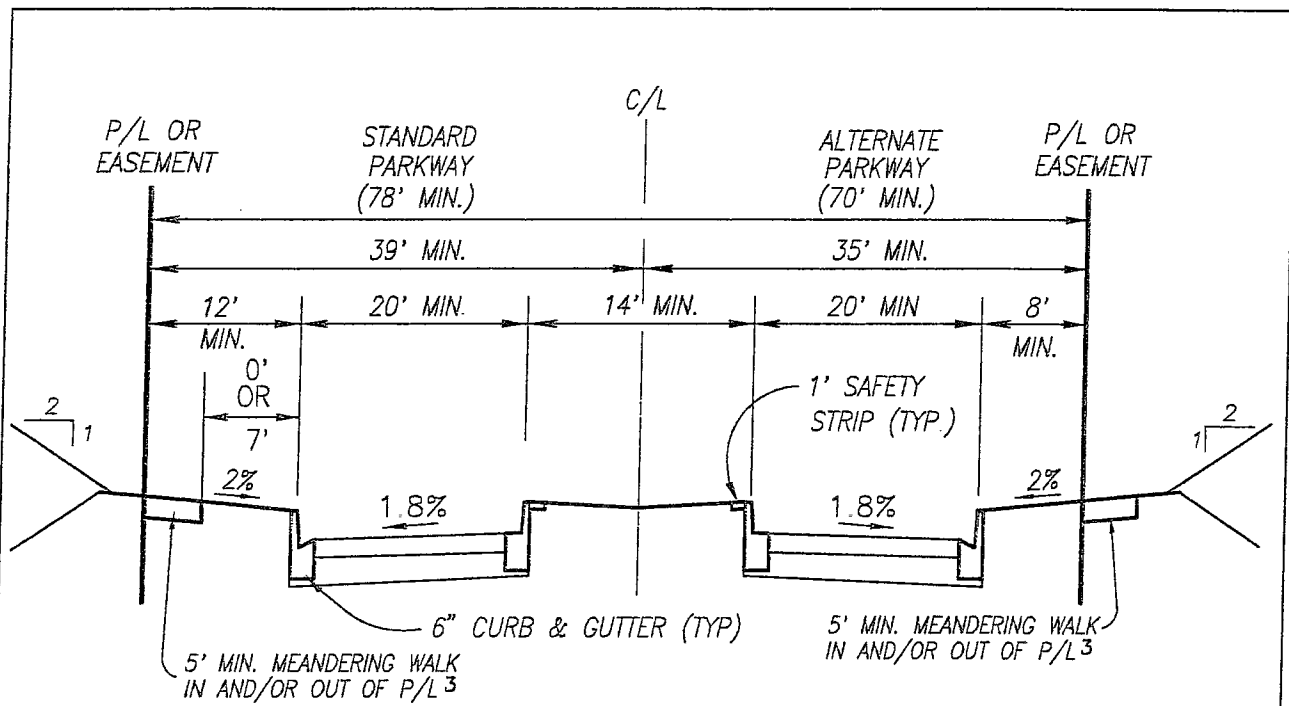

**4 PRIVATE DRIVE-GATED  
ENTRY RESIDENTIAL**  
N.T.S.

(SEE GATE DETAILS FIG. 10 AND 11 ON PAGES A18 AND A19)

**DESIGN DATA**

	STANDARD	ALTERNATE
MIN. OVERALL WIDTH (ft)	84	76
MIN. CURB TO CURB WIDTH (ft)	54	54
MIN. SIDEWALK WIDTH (ft)	5	5
LAND USE	SINGLE FAMILY RESIDENTIAL, DETACHED CONDOMINIUMS, MULTI-FAMILY RESIDENTIAL, LOCAL MIXED USE, OPEN SPACE, PARK	
ADT VOLUME (SF UNITS SERVED) <sup>2</sup>	4,500 ADT(500)	
	STANDARD	HILLSIDE
DESIGN SPEED (mph)	30	25
MINIMUM C/L RADIUS (ft)	250	150
MIN. TANGENT REVERSING CURVE (ft) <sup>1</sup>	100	100
MIN. TANGENT BROKEN BACK CURVES (ft) <sup>1</sup>	200	150
COMPOUND CURVE RADII (ft)	$\frac{2}{3}R1 \leq R2 \leq R1$	$\frac{2}{3}R1 \leq R2 \leq R1$
MAXIMUM GRADE	10%	15%
MAXIMUM LANDING GRADE	3%	5%
MINIMUM LANDING LENGTH (ft)	100	50
RESTRICTIONS	LIMITED DRIVEWAY ACCESS	

1 ELIMINATE TANGENT IF MINIMUM TANGENT LENGTH CANNOT BE SATISFIED.  
 2. ADT VOLUME ANALYSIS IS THE BASIS OF DESIGN AND SUPERCEDES UNITS OR BUILDING AREA.  
 3. BASE MAY BE REQUIRED PER SOILS ENGINEER'S RECOMMENDATIONS.

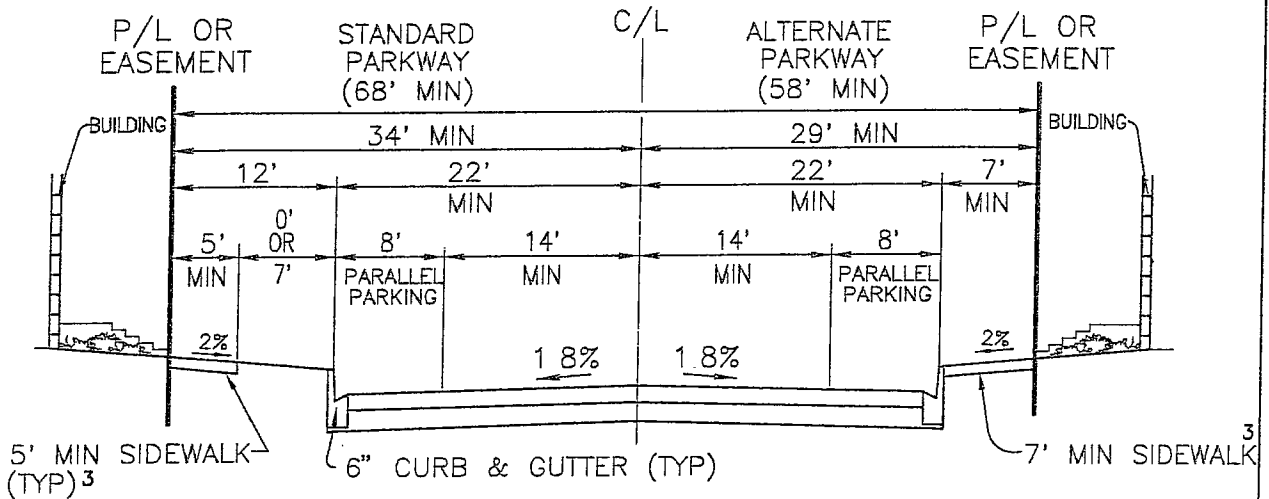

5
**PRIVATE DRIVE-URBAN  
W/ PARALLEL PARKING**  
 N.T.S.

**DESIGN DATA**

	STANDARD	ALTERNATE
MIN. OVERALL WIDTH (ft)	68	58
MIN. CURB TO CURB WIDTH (ft)	44	44
MIN. SIDEWALK WIDTH (ft)	5	7
LAND USE	MULTI-FAMILY RESIDENTIAL, MIXED USE, COMMERCIAL	
ADT VOLUME (SF UNITS SERVED) <sup>2</sup>	1,800 ADT(200)	
	STANDARD	HILLSIDE
DESIGN SPEED (mph)	30	25
MINIMUM C/L RADIUS (ft)	250	150
MIN. TANGENT REVERSING CURVE (ft) <sup>1</sup>	100	100
MIN. TANGENT BROKEN BACK CURVES (ft) <sup>1</sup>	200	150
COMPOUND CURVE RADII (ft)	$\frac{2}{3}R1 \leq R2 \leq R1$	$\frac{2}{3}R1 \leq R2 \leq R1$
MAXIMUM GRADE	10%	15%
MAXIMUM LANDING GRADE	3%	5%
MINIMUM LANDING LENGTH (ft)	100	50
RESTRICTIONS		

1. ELIMINATE TANGENT IF MINIMUM TANGENT LENGTH CANNOT BE SATISFIED.
2. ADT VOLUME ANALYSIS IS THE BASIS OF DESIGN AND SUPERCEDES UNITS OR BUILDING AREA.
3. BASE MAY BE REQUIRED PER SOILS ENGINEER'S RECOMMENDATIONS.

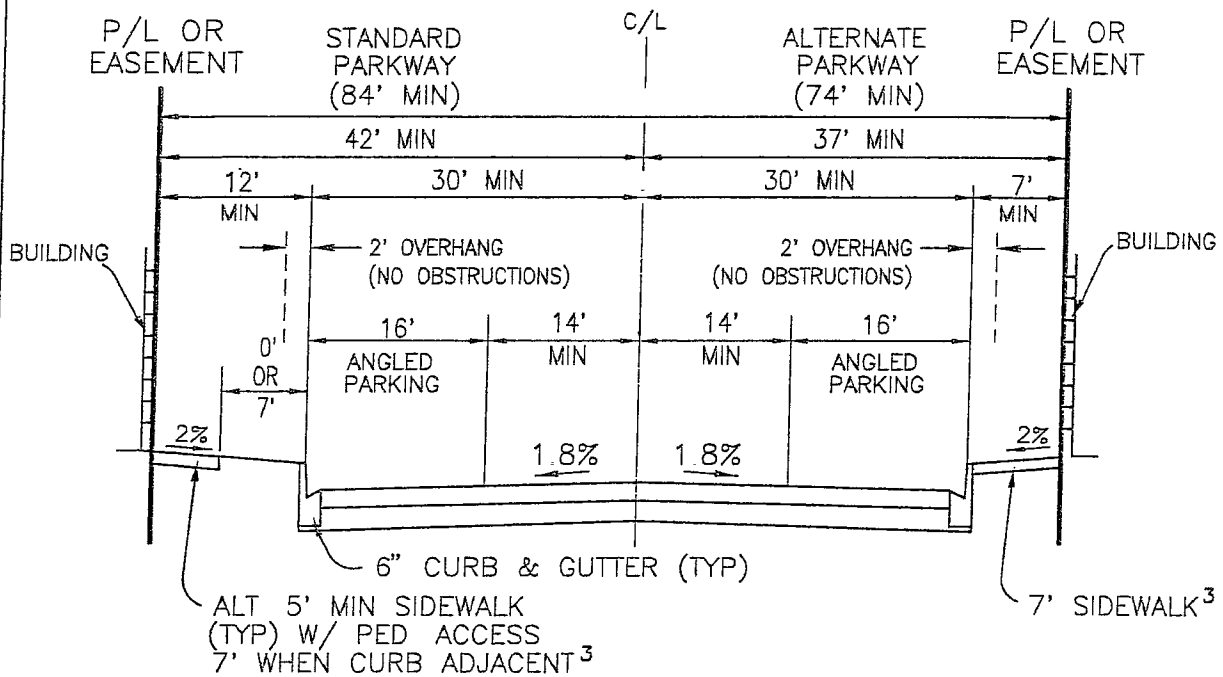

**6a PRIVATE DRIVE-LOCAL COLLECTOR-NO MEDIAN W/ ANGLED PARKING**

N.T.S.

**DESIGN DATA**

	STANDARD	ALTERNATE
MIN. OVERALL WIDTH (ft)	84	74
MIN. CURB TO CURB WIDTH (ft)	60	60
MIN. SIDEWALK WIDTH (ft)	5	7
LAND USE	MULTI-FAMILY RESIDENTIAL, MIXED USE, COMMERCIAL	
ADT VOLUME (SF UNITS SERVED) <sup>2</sup>	3,600 ADT(400)	
	STANDARD	HILLSIDE
DESIGN SPEED (mph)	25	25
MINIMUM C/L RADIUS (ft)	150	150
MIN. TANGENT REVERSING CURVE (ft) <sup>1</sup>	100	100
MIN. TANGENT BROKEN BACK CURVES (ft) <sup>1</sup>	200	150
COMPOUND CURVE RADII (ft)	$\frac{2}{3}R_1 \leq R_2 \leq R_1$	$\frac{2}{3}R_1 \leq R_2 \leq R_1$
MAXIMUM GRADE	10%	15%
MAXIMUM LANDING GRADE	3%	5%
MINIMUM LANDING LENGTH (ft)	100	50
RESTRICTIONS		

- 1 ELIMINATE TANGENT IF MINIMUM TANGENT LENGTH CANNOT BE SATISFIED.
2. ADT VOLUME ANALYSIS IS THE BASIS OF DESIGN AND SUPERCEDES UNITS OR BUILDING AREA.
3. BASE MAY BE REQUIRED PER SOILS ENGINEER'S RECOMMENDATIONS.

DATE: JUNE 2009

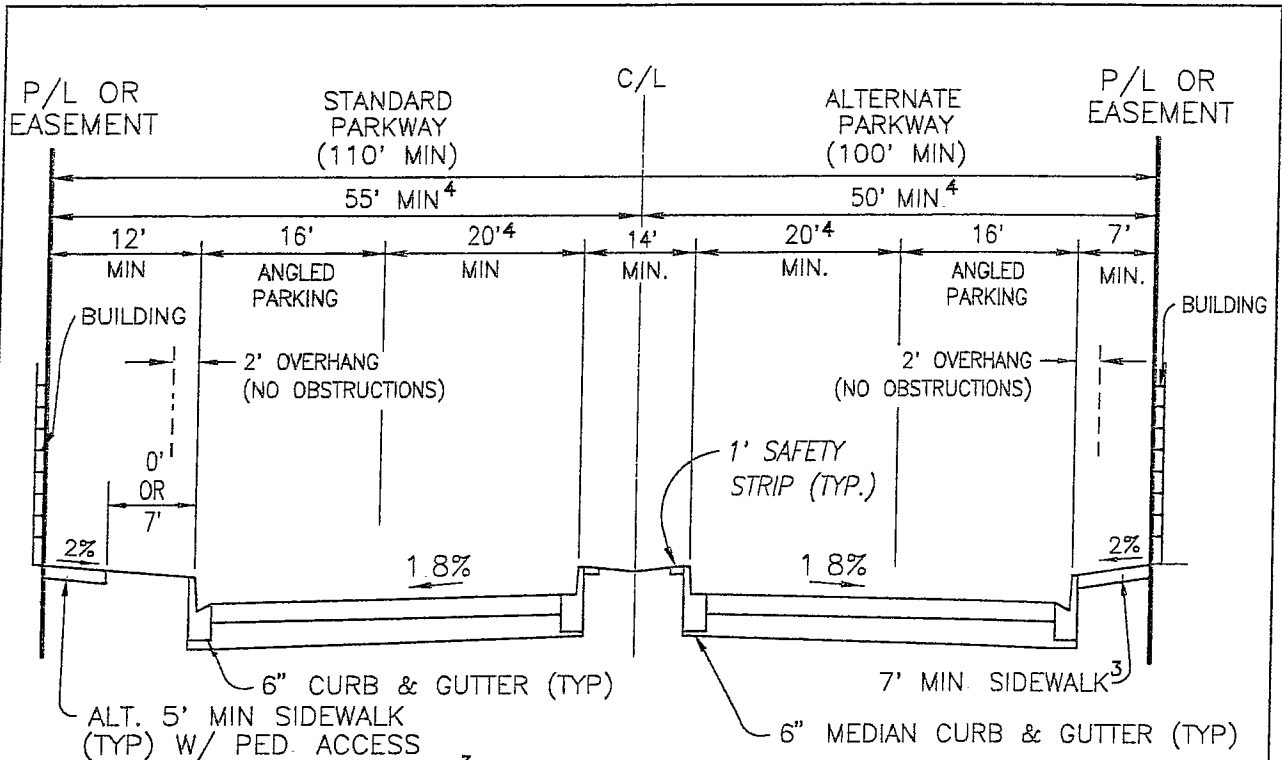

**6b** PRIVATE DRIVE-LOCAL COLLECTOR-W/ MEDIAN<sup>4</sup>  
W/ ANGLED PARKING  
DESIGN DATA N.T.S.

	STANDARD	ALTERNATE
MIN. OVERALL WIDTH (ft)	110	100
MIN. CURB TO CURB WIDTH (ft)	86	86
MIN. SIDEWALK WIDTH (ft)	5	7
LAND USE	MULTI-FAMILY RESIDENTIAL, MIXED USE, COMMERCIAL	
ADT VOLUME (SF UNITS SERVED) <sup>2</sup>	4,500 ADT(500)	
	STANDARD	HILLSIDE
DESIGN SPEED (mph)	25	25
MINIMUM C/L RADIUS (ft)	150	150
MIN. TANGENT REVERSING CURVE (ft) <sup>1</sup>	100	100
MIN. TANGENT BROKEN BACK CURVES (ft) <sup>1</sup>	200	150
COMPOUND CURVE RADII (ft)	$\frac{2}{3}R1 \leq R2 \leq R1$	$\frac{2}{3}R1 \leq R2 \leq R1$
MAXIMUM GRADE	10%	15%
MAXIMUM LANDING GRADE	3%	5%
MINIMUM LANDING LENGTH (ft)	100	50
RESTRICTIONS	SUBJECT TO APPLICATION AND APPROVAL BY FIRE DEPARTMENT	

1. ELIMINATE TANGENT IF MINIMUM TANGENT LENGTH CANNOT BE SATISFIED.
2. ADT VOLUME ANALYSIS IS THE BASIS OF DESIGN AND SUPERCEDES UNITS OR BUILDING AREA.
3. BASE MAY BE REQUIRED PER SOILS ENGINEER'S RECOMMENDATIONS.
4. WHEN ROAD ACCESS TO STRUCTURES IS NOT REQUIRED FOR EMERGENCY VEHICLES.

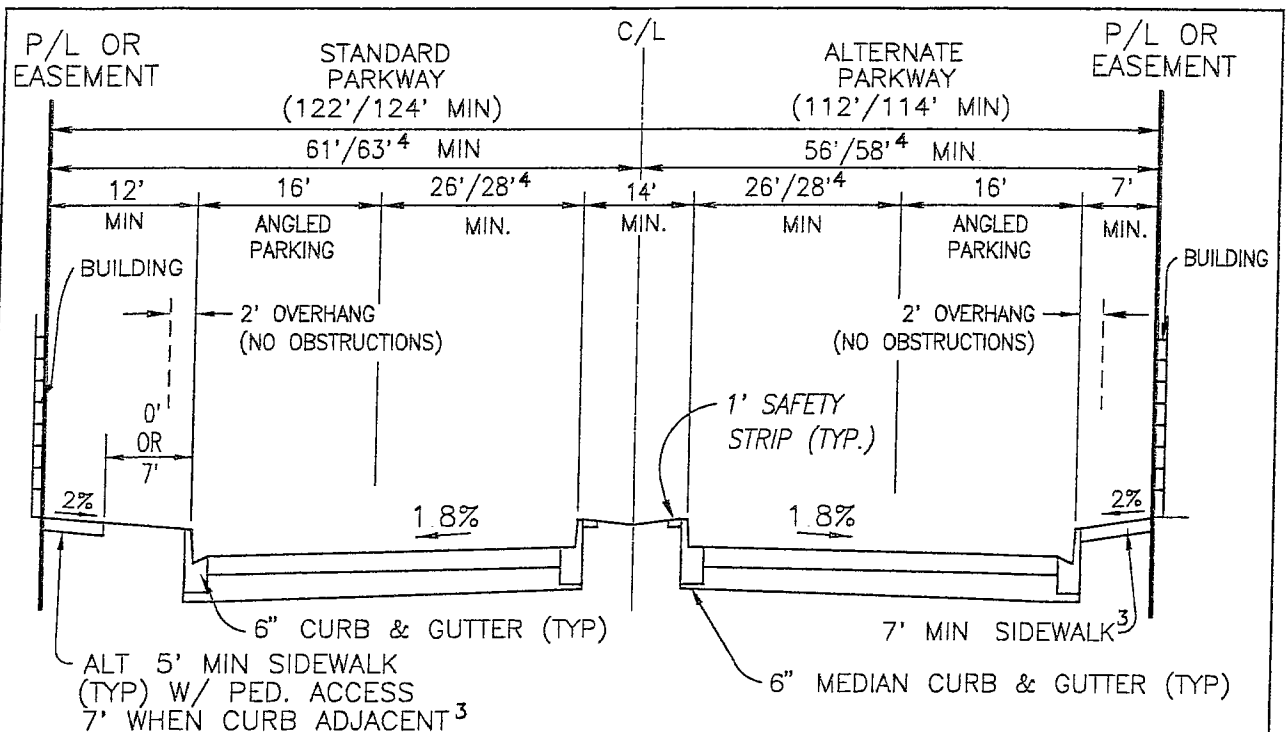

**6c PRIVATE DRIVE-LOCAL COLLECTOR-W/ MEDIAN<sup>4</sup>**  
**W/ ANGLED PARKING**  
 DESIGN DATA      N.T.S.

	STANDARD	ALTERNATE
MIN. OVERALL WIDTH (ft)	122	112
MIN. CURB TO CURB WIDTH (ft)	98	98
MIN. SIDEWALK WIDTH (ft)	5	7
LAND USE	MULTI-FAMILY RESIDENTIAL, MIXED USE, COMMERCIAL	
ADT VOLUME (SF UNITS SERVED) <sup>2</sup>	4,500 ADT(500)	
	STANDARD	HILLSIDE
DESIGN SPEED (mph)	25	25
MINIMUM C/L RADIUS (ft)	150	150
MIN. TANGENT REVERSING CURVE (ft) <sup>1</sup>	100	100
MIN. TANGENT BROKEN BACK CURVES (ft) <sup>1</sup>	200	150
COMPOUND CURVE RADII (ft)	$\frac{2}{3}R1 \leq R2 \leq R1$	$\frac{2}{3}R1 \leq R2 \leq R1$
MAXIMUM GRADE	10%	15%
MAXIMUM LANDING GRADE	3%	5%
MINIMUM LANDING LENGTH (ft)	100	50
RESTRICTIONS	SUBJECT TO APPLICATION AND APPROVAL BY FIRE DEPARTMENT	

1. ELIMINATE TANGENT IF MINIMUM TANGENT LENGTH CANNOT BE SATISFIED.
2. ADT VOLUME ANALYSIS IS THE BASIS OF DESIGN AND SUPERCEDES UNITS OR BUILDING AREA.
3. BASE MAY BE REQUIRED PER SOILS ENGINEER'S RECOMMENDATIONS.
4. WHEN ROAD ACCESS TO STRUCTURES IS REQUIRED FOR EMERGENCY VEHICLES:  
 26' FOR STRUCTURES <35' IN HEIGHT  
 28' FOR STRUCTURES >35' IN HEIGHT

DATE: JUNE 2009



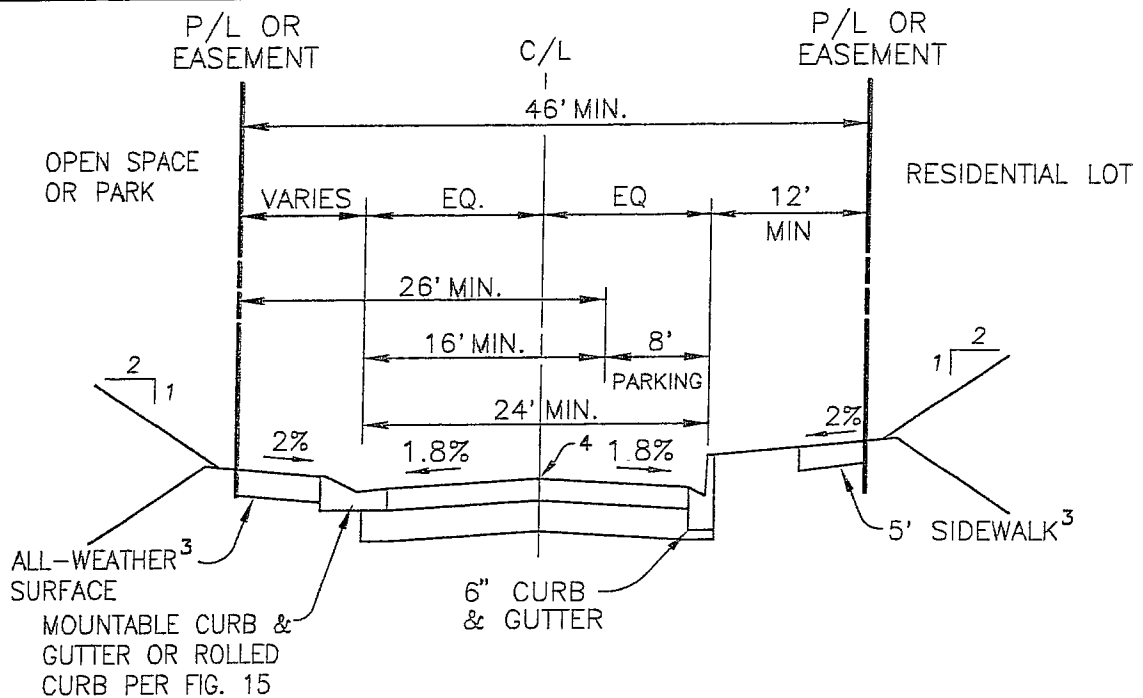

**7a PRIVATE DRIVE-ONE WAY  
W/ PARALLEL PARKING ON ONE SIDE**  
N.T.S.

**DESIGN DATA**

	STANDARD	ALTERNATE
MIN. OVERALL WIDTH (ft)	46	N/A
MIN. CURB TO CURB WIDTH (ft)	24	N/A
MIN. SIDEWALK WIDTH (ft)	5	N/A
LAND USE	SINGLE FAMILY RESIDENTIAL, DETACHED CONDOMINIUMS, MULTI-FAMILY RESIDENTIAL < 35', LOCAL MIXED USE, OPEN SPACE, PARK	
ADT VOLUME (SF UNITS SERVED) <sup>2</sup>	1,350 ADT(150)	
	STANDARD	HILLSIDE
DESIGN SPEED (mph)	20	15
MINIMUM C/L RADIUS (ft)	100	100
MIN. TANGENT REVERSING CURVE (ft) <sup>1</sup>	100	100
MIN. TANGENT BROKEN BACK CURVES (ft) <sup>1</sup>	200	150
COMPOUND CURVE RADII (ft)	$\frac{2}{3}R1 \leq R2 \leq R1$	$\frac{2}{3}R1 \leq R2 \leq R1$
MAXIMUM GRADE	10%	15%
MAXIMUM LANDING GRADE	3%	5%
MINIMUM LANDING LENGTH (ft)	50	25
RESTRICTIONS	NO SINGLE FAMILY DRIVEWAY ACCESS SUBJECT TO APPLICATION AND APPROVAL BY FIRE DEPARTMENT	

1. ELIMINATE TANGENT IF MINIMUM TANGENT LENGTH CANNOT BE SATISFIED.
2. ADT VOLUME ANALYSIS IS THE BASIS OF DESIGN AND SUPERCEDES UNITS OR BUILDING AREA.
3. BASE MAY BE REQUIRED PER SOILS ENGINEER'S RECOMMENDATIONS.
4. CROWN MAY BE ELIMINATED AT THE DISCRETION OF THE PROJECT ENGINEER.

DATE: JUNE 2009



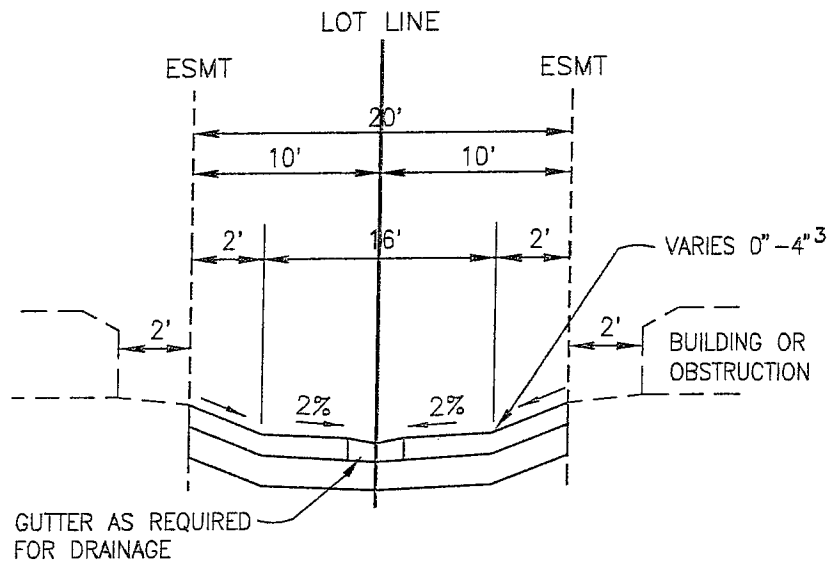

8a

**PRIVATE DRIVE-ALLEY**  
**NO FIRE ACCESS**

N T S.

DESIGN DATA

	STANDARD	ALTERNATE
MIN. OVERALL WIDTH (ft)	20	N/A
MIN. CURB TO CURB WIDTH (ft)	16	N/A
MIN. SIDEWALK WIDTH (ft)	N/A	N/A
LAND USE	SINGLE FAMILY RESIDENTIAL, DETACHED CONDOMINIUMS	
ADT VOLUME (SF UNITS SERVED) <sup>2</sup>	450 ADT(50)	
	STANDARD	HILLSIDE
DESIGN SPEED (mph)	15	15
MINIMUM C/L RADIUS (ft)	75	75
MIN. TANGENT REVERSING CURVE (ft) <sup>1</sup>	N/A	N/A
MIN. TANGENT BROKEN BACK CURVES (ft) <sup>1</sup>	N/A	N/A
COMPOUND CURVE RADII (ft)	$\frac{2}{3}R1 \leq R2 \leq R1$	$\frac{2}{3}R1 \leq R2 \leq R1$
MAXIMUM GRADE	10%	15%
MAXIMUM LANDING GRADE	3%	5%
MINIMUM LANDING LENGTH (ft)	25	25
RESTRICTIONS	NO EMERGENCY FIRE ACCESS REQUIRED	

1. ELIMINATE TANGENT IF MINIMUM TANGENT LENGTH CANNOT BE SATISFIED.
2. ADT VOLUME ANALYSIS IS THE BASIS OF DESIGN AND SUPERCEDES UNITS OR BUILDING AREA.
3. HIKE VARIES DEPENDING UPON DRAINAGE REQUIREMENTS OF PROJECT

DATE: JUNE 2009

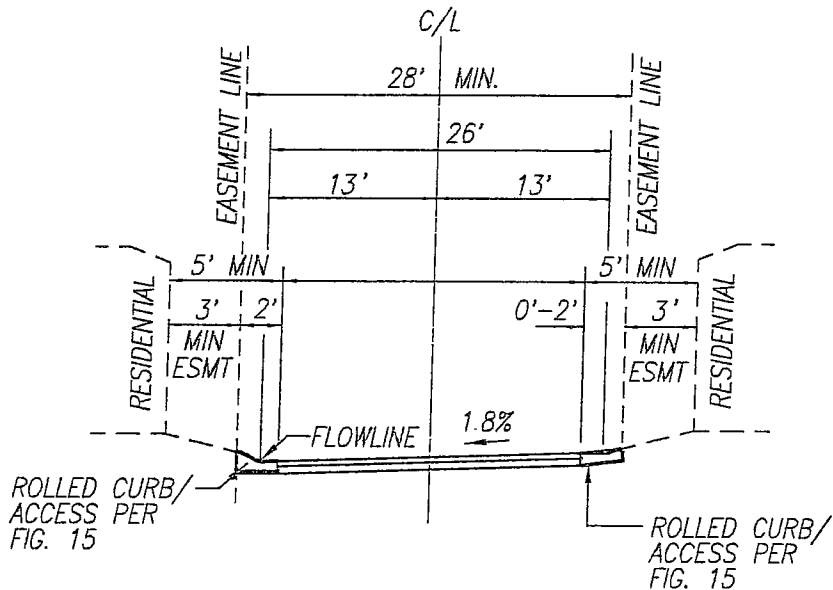

**8b**      **PRIVATE DRIVE-ALLEY**  
N. T. S.

DESIGN DATA

	STANDARD	ALTERNATE
MIN. OVERALL WIDTH (ft)	28	N/A
MIN. CURB TO CURB WIDTH (ft)	26	N/A
MIN. SIDEWALK WIDTH (ft)	N/A	N/A
LAND USE	SINGLE FAMILY RESIDENTIAL, DETACHED CONDOMINIUMS	
ADT VOLUME (SF UNITS SERVED) <sup>2</sup>	650 ADT(75)	
	STANDARD	HILLSIDE
DESIGN SPEED (mph)	15	15
MINIMUM C/L RADIUS (ft)	75	75
MIN. TANGENT REVERSING CURVE (ft) <sup>1</sup>	N/A	N/A
MIN. TANGENT BROKEN BACK CURVES (ft) <sup>1</sup>	N/A	N/A
COMPOUND CURVE RADII (ft)	$\frac{2}{3}R1 \leq R2 \leq R1$	$\frac{2}{3}R1 \leq R2 \leq R1$
MAXIMUM GRADE	10%	15%
MAXIMUM LANDING GRADE	3%	5%
MINIMUM LANDING LENGTH (ft)	25	25
RESTRICTIONS		

1. ELIMINATE TANGENT IF MINIMUM TANGENT LENGTH CANNOT BE SATISFIED.
2. ADT VOLUME ANALYSIS IS THE BASIS OF DESIGN AND SUPERCEDES UNITS OR BUILDING AREA.

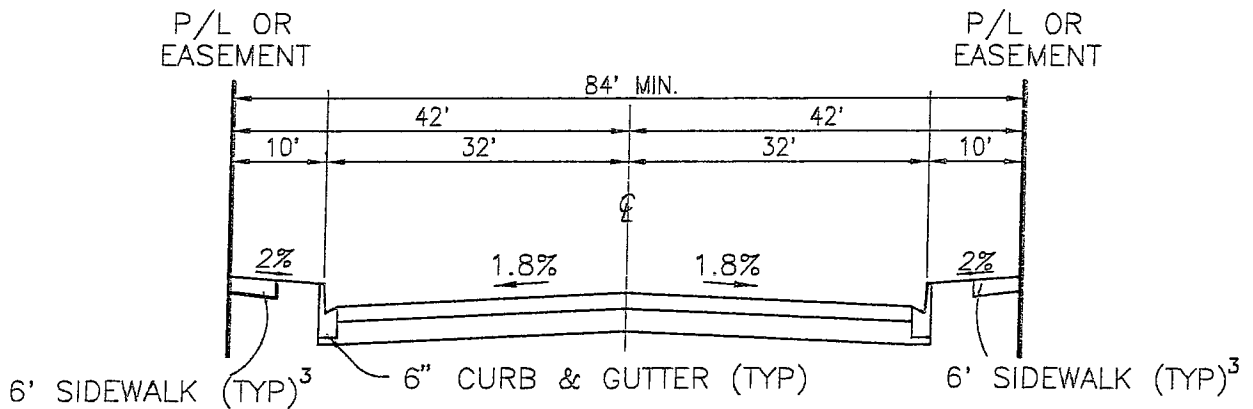

**9 INDUSTRIAL / COMMERCIAL LOOP**  
**PRIVATE DRIVE**

N.T.S.

**DESIGN DATA**

	STANDARD	ALTERNATE
MIN. OVERALL WIDTH (ft)	84	N/A
MIN. CURB TO CURB WIDTH (ft)	64	N/A
MIN. SIDEWALK WIDTH (ft)	6	N/A
LAND USE	COMMERCIAL / INDUSTRIAL	
BLDG AREA (sf) SERVED (ADT VOLUME)	1,400,000 sf	(10,000 ADT)
	STANDARD	HILLSIDE
DESIGN SPEED (mph)	40 <sup>4</sup>	40 <sup>4</sup>
MINIMUM C/L RADIUS (ft)	500 <sup>4</sup>	500 <sup>4</sup>
MIN. TANGENT REVERSING CURVE (ft) <sup>1</sup>	100	100
MIN. TANGENT BROKEN BACK CURVES (ft) <sup>1</sup>	200	200
COMPOUND CURVE RADII (ft)	$\frac{2}{3}R1 \leq R2 \leq R1$	$\frac{2}{3}R1 \leq R2 \leq R1$
MAXIMUM GRADE	10%	10%
MAXIMUM LANDING GRADE	3%	4%
MINIMUM LANDING LENGTH (ft)	100'	50'
RESTRICTIONS		

1. ELIMINATE TANGENT IF MINIMUM TANGENT LENGTH CANNOT BE SATISFIED.
2. ADT VOLUME ANALYSIS IS THE BASIS OF DESIGN AND SUPERCEDES UNITS OR BUILDING AREA.
3. BASE MAY BE REQUIRED PER SOILS ENGINEER'S RECOMMENDATIONS.
4. A MINIMUM RADIUS OF 100' CAN BE UTILIZED IF CARRYING 1000 ADT OR LESS, WITH A 15 MPH DESIGN SPEED.

DATE: JUNE 2009



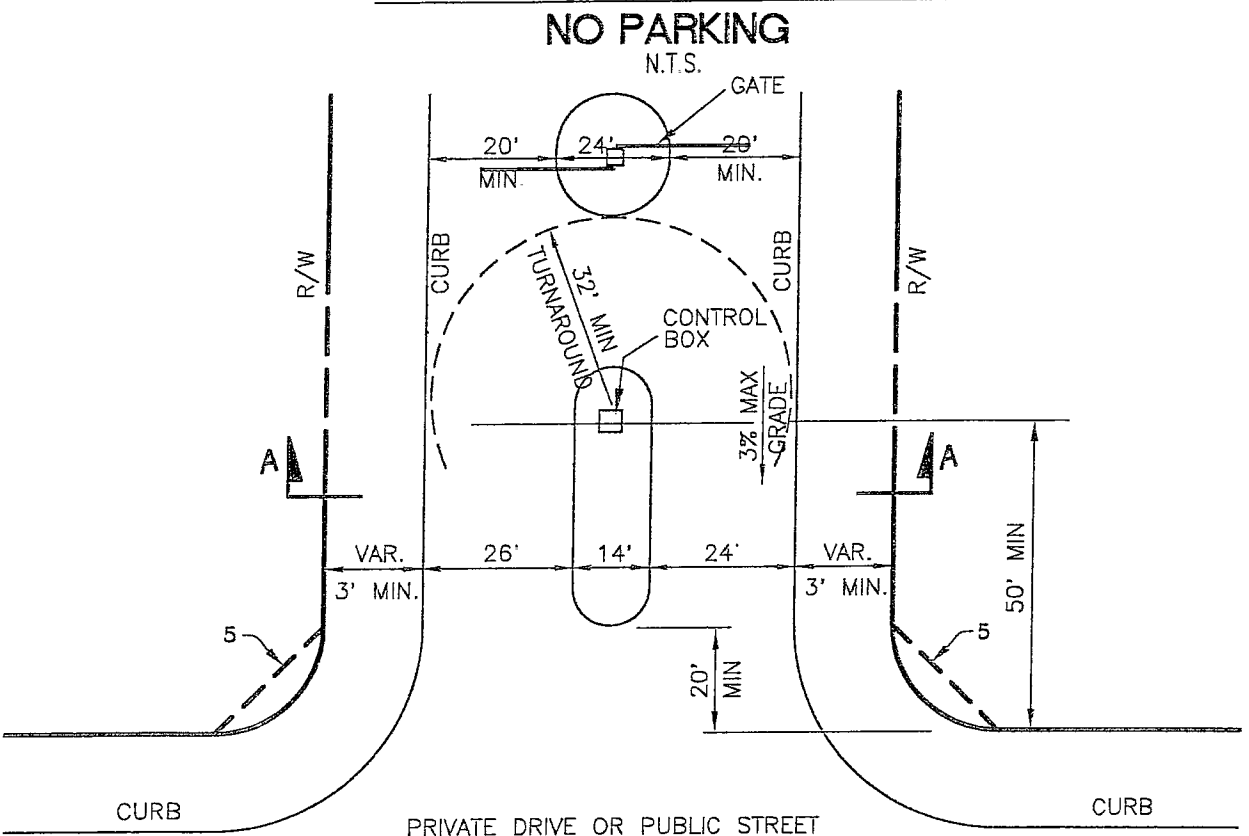
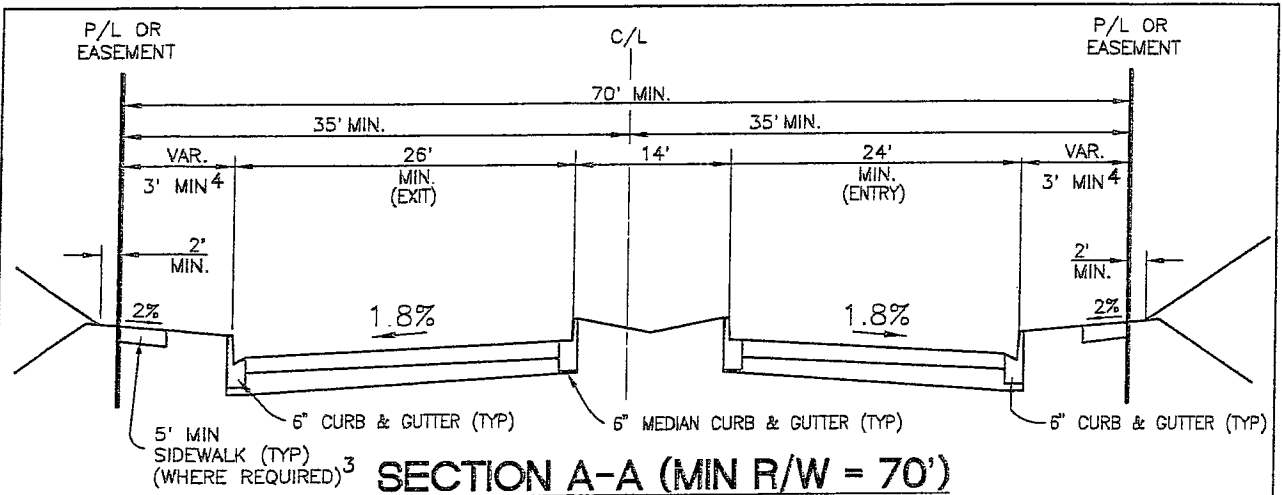

**11 TYPICAL GATE DETAIL WITHOUT GUARD SHACK**  
N.T.S.

- NOTES:**
1. DIMENSIONS SHOWN HEREON ARE MINIMUM REQUIREMENTS AND SUBJECT TO CHANGE. FINAL DIMENSIONS WILL BE BASED UPON TRAFFIC ENGINEER'S AND FIRE DEPARTMENT RECOMMENDATIONS.
  2. PUBLIC WORKS TO DETERMINE MINIMUM KEYPAD SET-BACK BASED ON THE TRAFFIC STUDY
  3. BASE MAY BE REQUIRED PER SOILS ENGINEER'S RECOMMENDATIONS BASED ON THE TRAFFIC STUDY
  4. PARKWAY CAN BE REDUCED TO 3' MIN. WHEN SIDEWALK IS NOT REQUIRED
  5. CORNER CUT-OFF IN P/L REQUIRED WHEN ADJACENT TO PUBLIC STREET

DATE: JUNE 2009

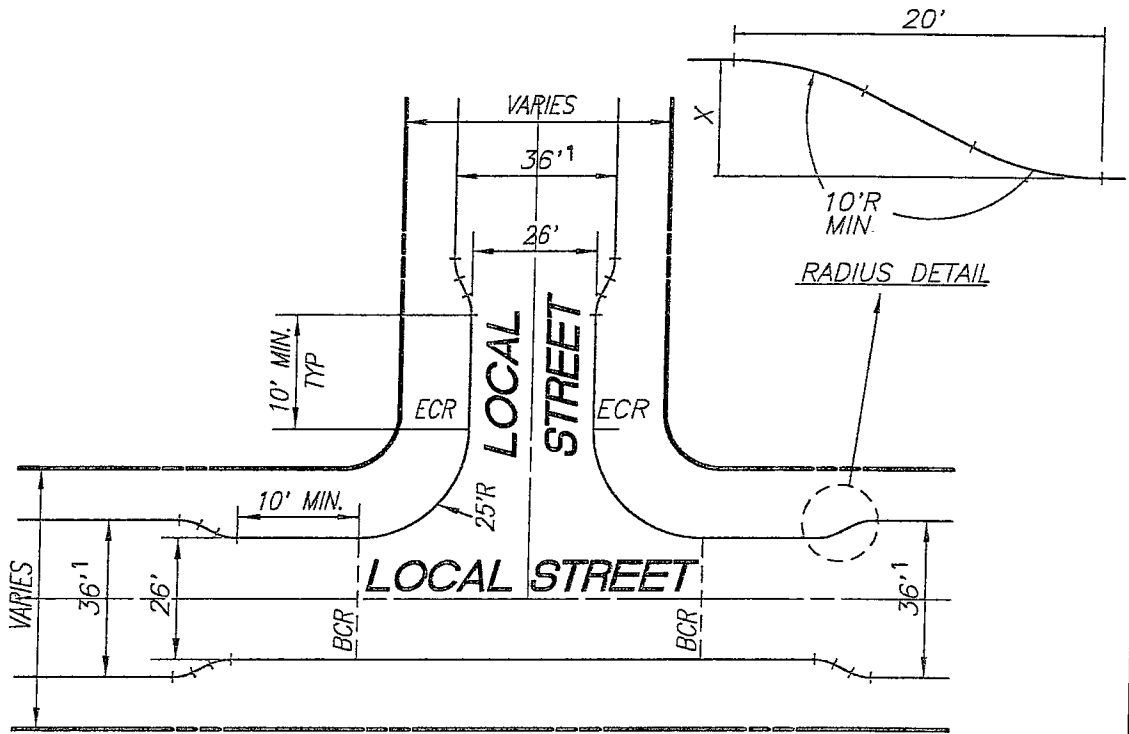

**TYPICAL PRIVATE DRIVE LOCAL INTERSECTION**

**(12) 3-WAY TRAFFIC CALMING DETAIL**

*N.T.S.*

1 REDUCTION IN WIDTH ALLOWED WITH THE APPROVAL OF LACDPW AND LACFD.  
34' MINIMUM WIDTH.



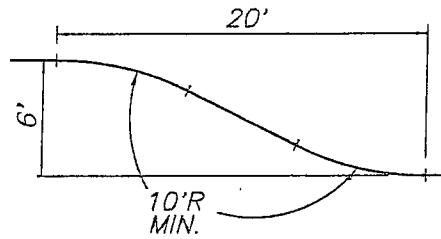

RADIUS DETAIL

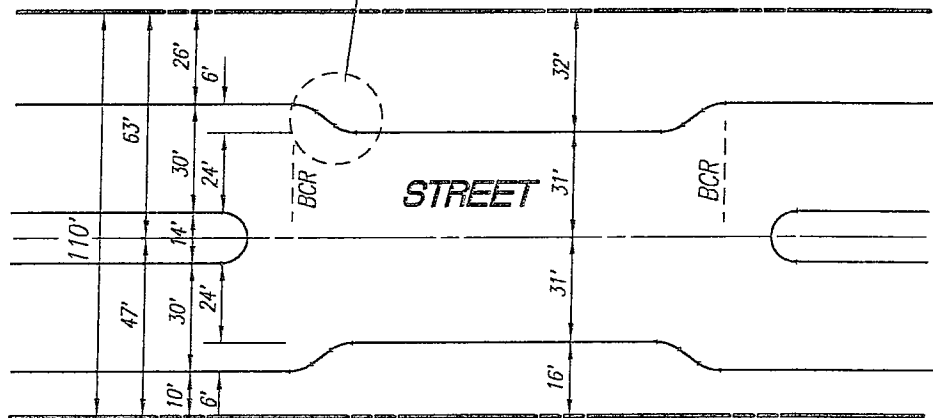

MID BLOCK

13 TRAFFIC CALMING DETAIL

N.T.S.

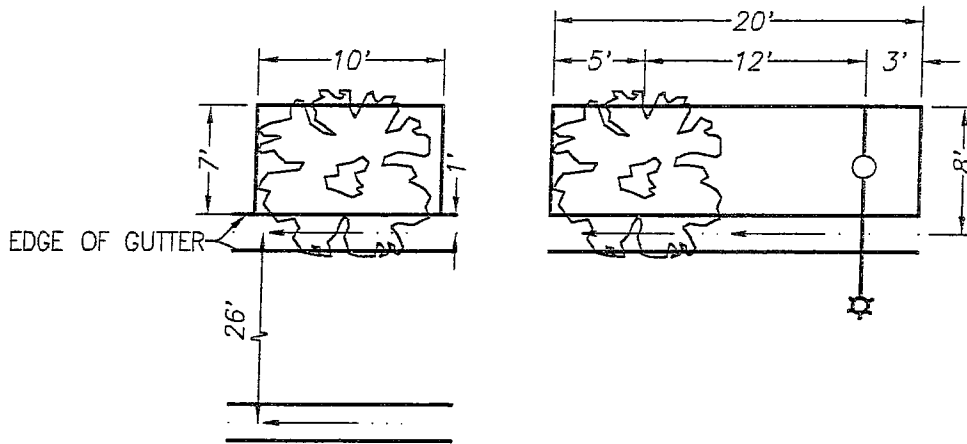

**TYPICAL STREET LIGHT AND  
TREE PLANTER DETAIL**

N.T.S.

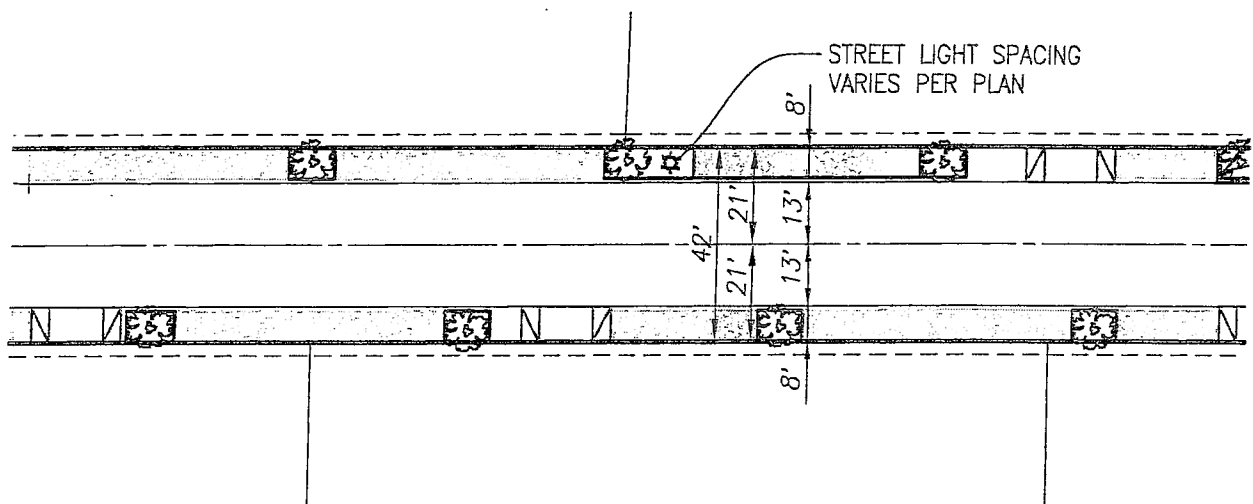

**LEGEND:**



PROPOSED TREE LAYOUT

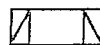

PROPOSED DRIVEWAY LAYOUT



PROPOSED STREET LIGHT



PROPOSED PARKING AREA

14

**TYPICAL HORIZONTAL GEOMETRY  
PRIVATE DRIVE - RURAL**

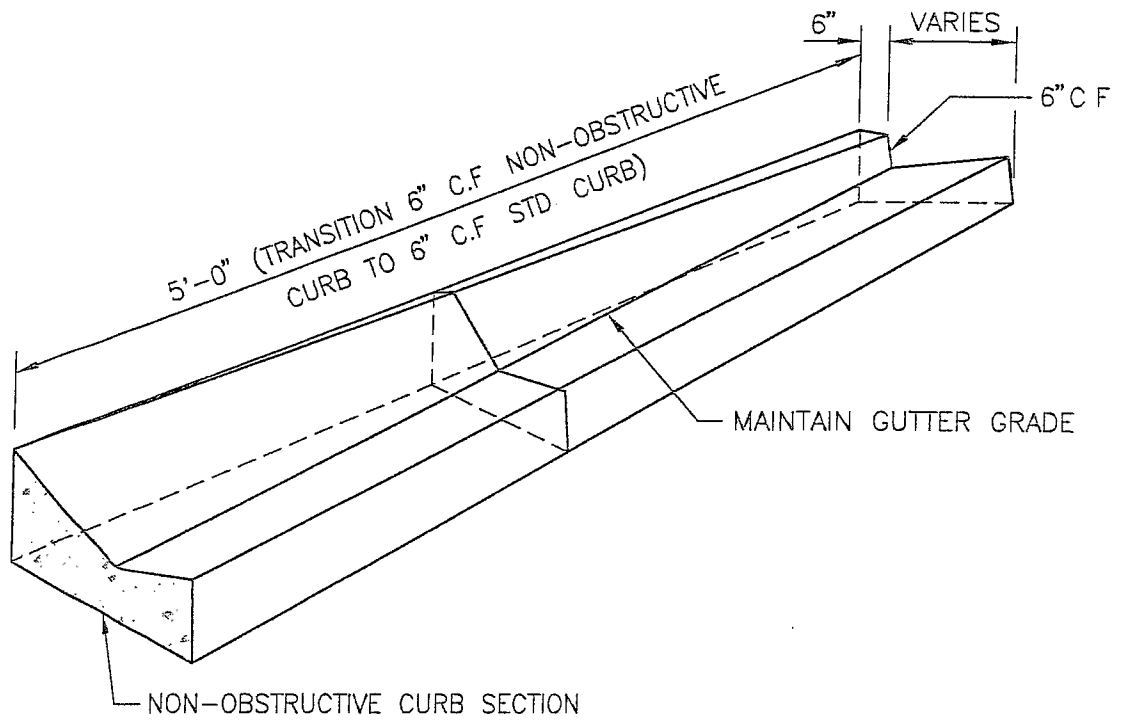

### CONCRETE CURB TRANSITION

N.T.S.

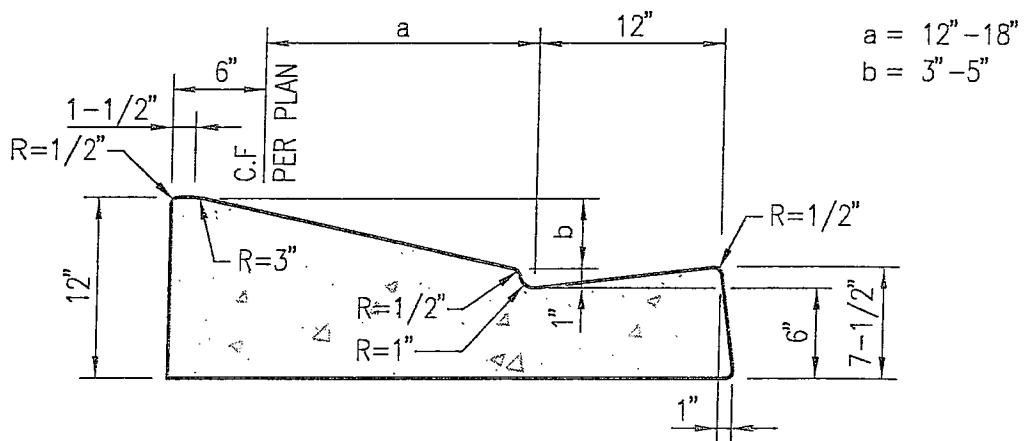

### 15 CONCRETE ROLLED CURB

N.T.S.